



HAFFMANS HEAT RECOVERY



IMPROVE THE EFFICIENCY OF YOUR OPERATION

INTRODUCTION

The brewing industry has passed the sustainability point of no return. Having reached its maximum potential, the industry is quickly moving from conventional solutions toward more advanced sustainable solutions that have higher performance with less effort. With Pentair Haffmans' Heat Recovery System (HRS) vaporizing carbon dioxide (CO₂) becomes an energy saving rather than a traditionally energy consuming process.

Heat recovery systems deliver

- fully automated CO₂ vaporization
- through a more sustainable process
- using less power and recovering more energy in the process
- with a smaller footprint and increased modularity
- at lower costs.

EFFICIENT PERFORMANCE TECHNOLOGY

As a leader in CO₂ recovery systems, Pentair's guiding principle in product development is its Efficient Performance Technology program that focuses on developing products that offer a significantly higher performance at a higher efficiency against competitive pricing, while protecting the environment and lowering customer costs.

The Efficient Performance Technology approach, supplemented with more than 60 years of experience in CO₂ and O₂ management provided the basis for the development of the Heat Recovery System.

The challenge

The current challenge in any industry is to reduce costs without sacrificing quality. In the beverage industry the cost to provide the required cold and hot energy streams is high. Thus any reduction in energy consumption will contribute to the bottom line as well as reduce emissions to the environment. Traditional methods of vaporizing liquid CO₂ use steam, ambient air or electrically heated water. Ambient air operated CO₂ vaporizers are only applicable when the ambient air temperature is high enough. Vaporizing liquid CO₂ with steam or hot water requires a great amount of energy.

A sustainable solution

With the HRS solution, Pentair Haffmans makes it all possible. The HRS uses hot waste streams to vaporize CO₂, recovers cold energy released during the process, and reduces operating costs all at the same time.

- Reduced Life Cycle Cost
 - Energy recovery, lowering refrigeration costs
 - Low pressure drop
 - Smart engineering, lower CAPEX
- Smaller Footprint
 - Compact vertical set up
 - Skid mounted unit
- Minimal Maintenance
 - No circulation pumps
 - Low wear & tear
- Increased Energy Recovery
 - Vaporizing CO₂ using a hot waste energy stream
 - Recovering cold energy released during vaporization of liquid CO₂
- Increased Modularity
 - Small to high output
 - Designed for various capacities
 - Alternative sizes at request
 - Parallel operation to existing units
- More Flexibility
 - Using existing energy streams
 - Handling various loads
 - Various superheating possibilities

TECHNICAL DATA

REFRIGERATION ENERGY SAVINGS

Vaporization

Up to 90 kW per 1,000 kg/h vaporized liquid CO₂

Superheating**

Up to 10 kW per 1,000 kg/h superheated CO₂ gas

** to 10 °C with 20 °C hot return water

CO₂ vaporizing capacity

300/750/1,000/1,500/2,000/2,500/3,000 kg/h
Other capacities are available on request

Hot waste streams

Brine/glycol water/ice water/cooling water/
NH₃/CO₂

Superheating CO₂ gas

- Further energy recovery through superheating CO₂ gas with hot return cooling water. This can be combined with the CO₂ vaporizer unit
- Alternatively, CO₂ gas superheating can take place with a separate ambient air super heater

To help our customers keep with the increasing demands of beer and beverage production Pentair Haffmans offers advanced sustainable solutions. Many years of designing and building CO₂ systems and applying this technology resulted in the LiquiVap HRS, which can reduce the energy consumption of traditional CO₂ recovery plants by up to 60 percent.

APPLICATIONS

Any location where liquid CO₂ is vaporized and a hot waste stream is available.

CASE STUDY

- Annual production 3.2 mil. hl
- Glycol costs: € 0.026/kW
- Steam costs: € 0.019/kg
- ROI < 14 MONTHS

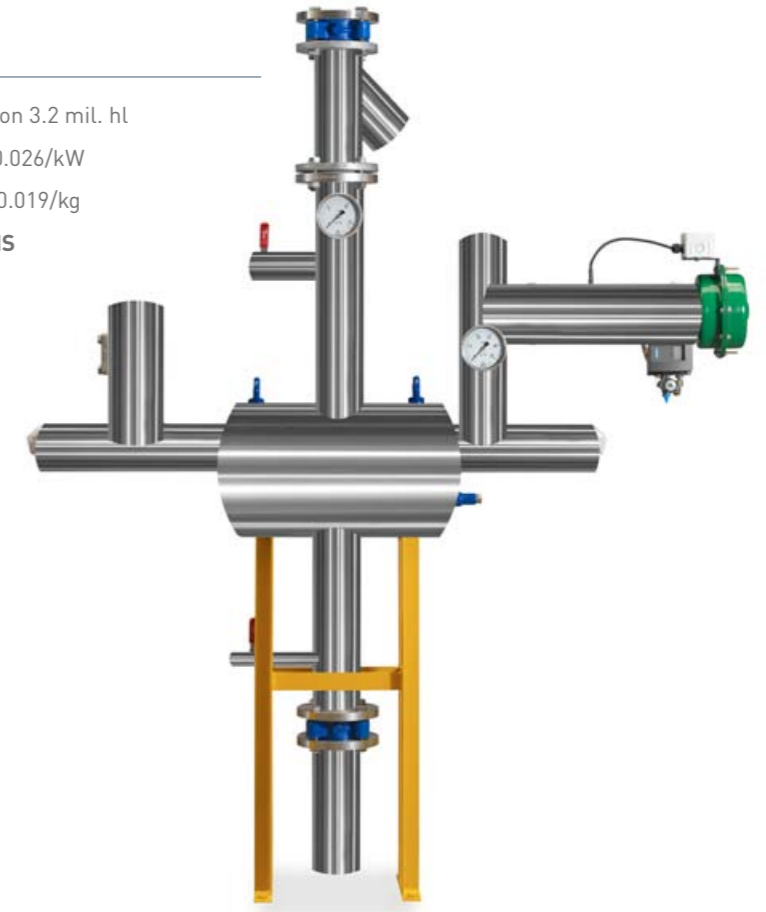

GLOBAL SERVICE MANAGEMENT



Today, service is much more than just repair and maintenance. Service contracts are an integral part of your preventive maintenance program.

It begins during project management when Pentair Haffmans' service team is introduced to the customer and assists with commissioning.



On-site the service team gathers valuable information about the local conditions of the operation. With performance data monitoring, we are able to acquire long-term information, which ensures that troubleshooting and service activities can be very efficient if an emergency occurs. By taking advantage of the full service contract a company can be assured that the potential for continuous improvement of a plant is explored on a regular basis, and thus place its focus on the core business.



Pentair Haffmans' life cycle/service management is divided into two phases: design and operation. Proposal/planning, contract management, and engineering up to commissioning are typical design services. Startup, monitoring, consulting [24/7 helpdesk], maintenance/replacement of components, evaluation, and optimization are part of the operation services. The overall goal is to ensure that a plant is constructed and operates in the best possible and most cost-efficient way.



HAFFMANS BV

P.O. BOX 3150, 5902 RD VENLO, NETHERLANDS WWW.HAFFMANS.NL

All Pentair trademarks and logos are owned by Pentair, Inc. All other brand or product names are trademarks or registered marks of their respective owners. Because we are continuously improving our products and services, Pentair reserves the right to change specifications without prior notice.

Pentair is an equal opportunity employer.

HRS E-5/12 © 2012 Pentair, Inc. All Rights Reserved.