



Self-cleaning filter BF2-S

Using so-called "self-cleaning" gas filters is worth considering for sample gas systems where secondary contamination primarily consisting of larger particles are to be expected.

The functional principle of these filters is that of the 'Cross Flow' process. Here a partial stream is continuously adequate for analysis is continuously extracted from the main sample gas flow. Inside the housing, the main stream is forced along the filter element in a spiral. The dirt particles from the partial stream deposited on the surface of the element are carried along by the main stream and discharged. The continuous discharge of dirt deposit results in a very long filter element life, thus low maintenance.

The BF2-S was developed specifically for these applications.

For fluids and gasses

Long filter life

Low maintenance

Compact installation

Pipe fitting included



Dimensions

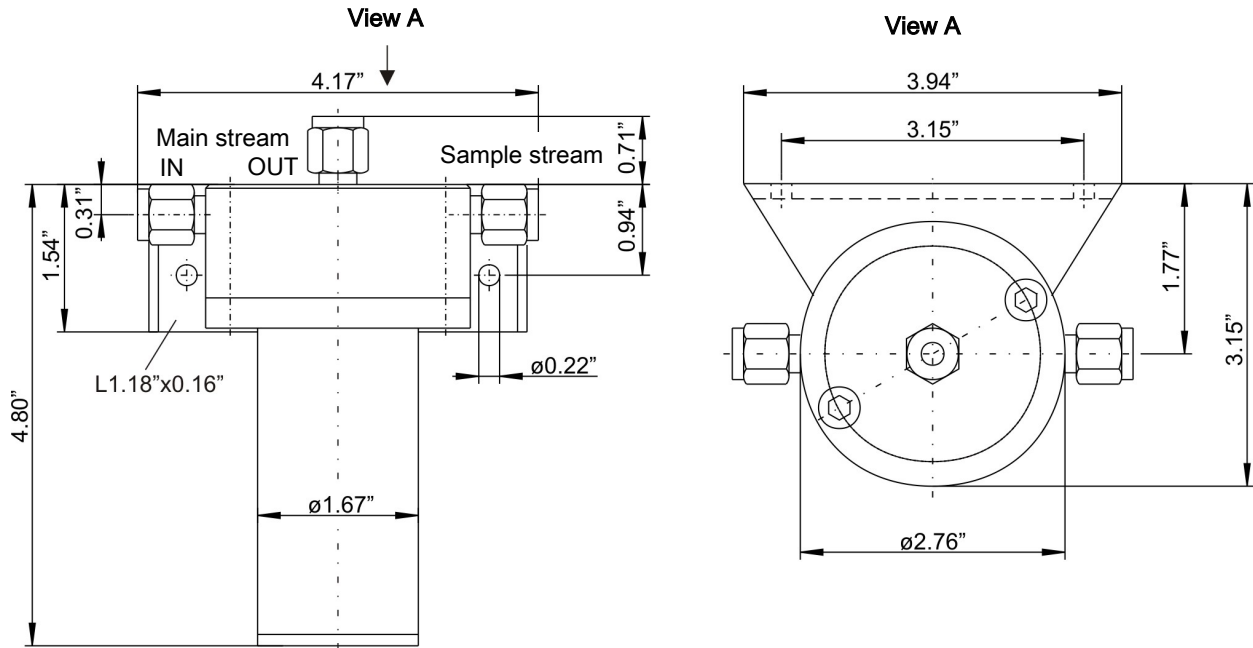

Flow characteristics

The flow rates indicated automatically arise when the main and sample stream discharge to outside.

- Element 5 M - 29 - 100 Filter fineness 5 micron
- - - - - Element 0.5 M - 29 - 100 Filter fineness 0.5 micron

Total	Main stream	Sample stream
A1	A2	A3
B1	B2	B3

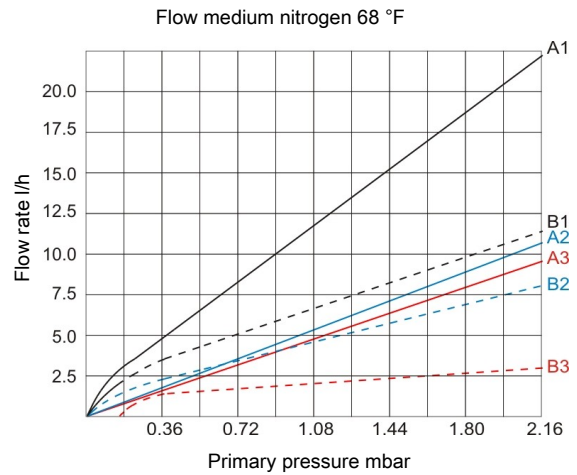
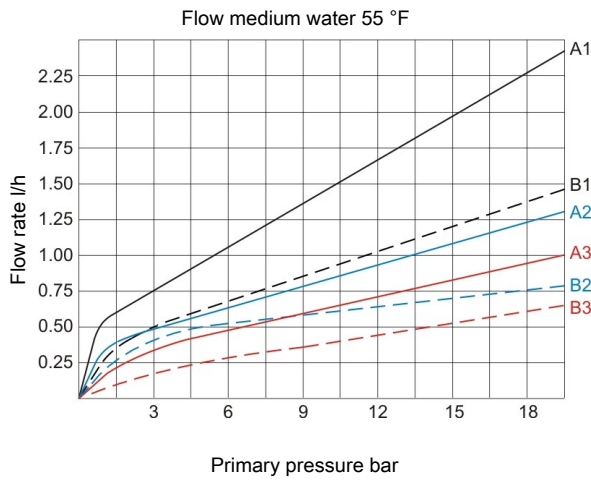

Technical Data

Fine mesh filter BF2-S

Material – Housing	1.4571
Material – Arbor	PTFE
Material – Filter element	1.4404
Material – Gasket	Viton
Connections	fitting for Ø 6 mm (0.24 in) pipe
Weight	approx. 3.3 lb
Filter surface	19.4 in ²
Filter fineness	0.5 or 5 µm
Operating pressure max.	362 psig
Operating temperature max.	248 °F

Ordering instructions**Filter***

Item no.	Model	Filter fineness
41 09 999	BF2-S-0.5	0.5 µm
41 08 999	BF2-S-5	5 µm

* one filter element is included with delivery.

Filter elements

Item no.	Model	Packing unit
41 09 001	0.5M - 29 - 100	1 pieces
41 08 001	5M - 29 - 100	1 pieces