

Highlights

- High temperature enclosure for MP150 linescanner withstands process temperatures up to 1090°C
- Modular system with choice of cooling options allows user to configure to suit application
- Rugged stainless steel construction
- Integrated shutter for fail-safe operation
- Designed to provide cooling with water or air or both
- Part number: XXXSYSENC

Process Temperatures

Enclosure + Vortex Cooler + External Insulating Shield	340°C
Enclosure + Vortex Cooler + External Water Cooled Shield	540°C
Enclosure + Vortex Cooler + External Water Cooled Shield + External Insulating Shield	760°C
Enclosure + Internal Cold Plates + Vortex Cooler + External Water Cooled Shield + External Insulating Shield	1090°C

Pressures

Integrated Shutter	max. 8 bar
Scanner Air Purge	max. 3 bar
Internal Cold Plates	max. 8 bar
External Water Cooled Shield	max. 8 bar
Vortex Cooler	max. 7 bar

Flow Rate

Water

Internal Cold Plates	min. 1 l/min
External Water Cooled Shield	min. 7.6 l/min

Air

Scanner Air Purge	100 to 200 l/min
Vortex Cooler (for heat dissipation of 820 W / 706 kcal/h)	1132 l/min

Material

Enclosure	stainless steel 1.4301 with refractory lining and base plate: hard coated Aluminum
External Water Cooled Shield	stainless steel 1.4301
External Insulating Shield	stainless steel 1.4301, packed with refractory
Vortex Cooler	stainless steel, type 316

MP150 High Temp Enclosure Datasheet



Scope of Delivery

The enclosure package includes the following:

- Stainless steel enclosure with base plate and mounting aperture for high performance vortex cooler
- Integrated fail-safe shutter
- 2" cable conduit, 1.5 m long

Options

Options must be specified at time of order.

Internal Cooled Plates (XXXSYSENCICP)

Internal cold plates cool scanner by contact. Eliminates the need to disconnect fittings to remove scanner. Supplied in sets of two.

Accessories

External Water Cooled Shield (XXXSYSENCWCS)

Stainless steel high performance water shield. ¾ inch water inlet and outlet permit high flow rates and extremely high heat removal capability.

External Insulating Shield (XXXSYSENCIS)

Insulated shield is a custom stainless steel envelope filled with high performance refractory material. Placed closest to the process, it prevents heat from entering the enclosure and lessens the heat removal requirements of other elements.

Vortex Cooler (XXXSYSENCVT)

High performance vortex cooler separates compressed air (or nitrogen) into hot and cold streams to actively cool enclosure interior, supplied with maintenance unit (particle filter, oil removal filter).

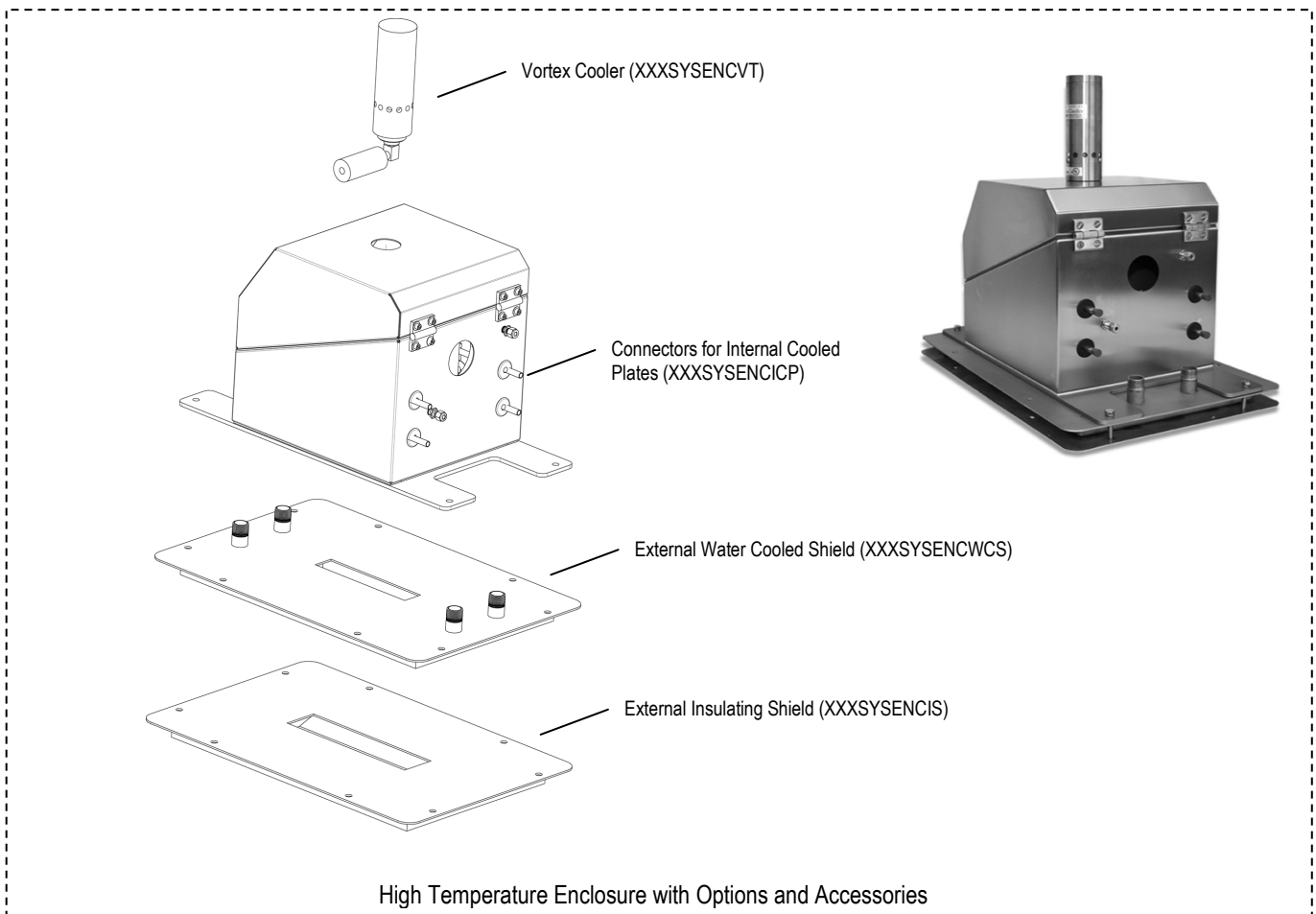
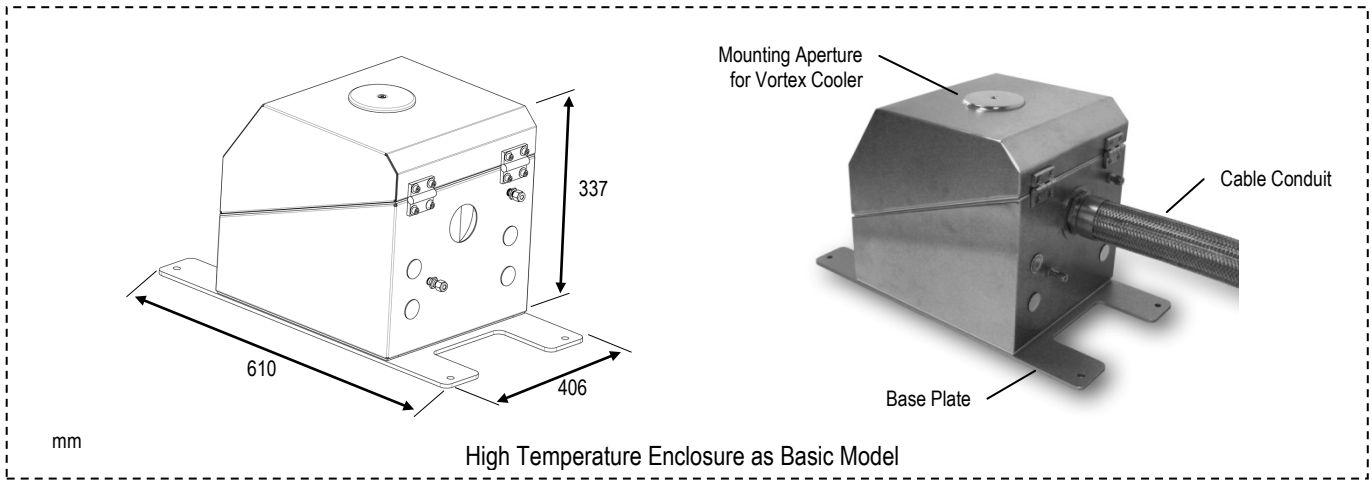

www.raytek.com

55524, Rev. C, 01/2011 – Raytek and the Raytek logo are registered trademarks of Raytek Corporation. Specifications subject to change without notice. Raytek is ISO 9001 certified.

Worldwide Headquarters
 Santa Cruz, CA USA
 Tel: +1 831 458 – 3900
 +1 800 227 – 8074
solutions@raytek.com

European Headquarters
 Berlin, Germany
 Tel: +49 30 47 80 08 0
 Fax: +49 30 4 71 02 51
raytek@raytek.de



United Kingdom
ukinfo@raytek.com

France
info@raytek.fr

Raytek®
 A Fluke Company