

INSTRUMENTATION SOLUTIONS

- Best Practices
- Heated Enclosures
- Sample Line Bundles
- Instrument Impulse Lines
- Instrument Supports
- Installation Services

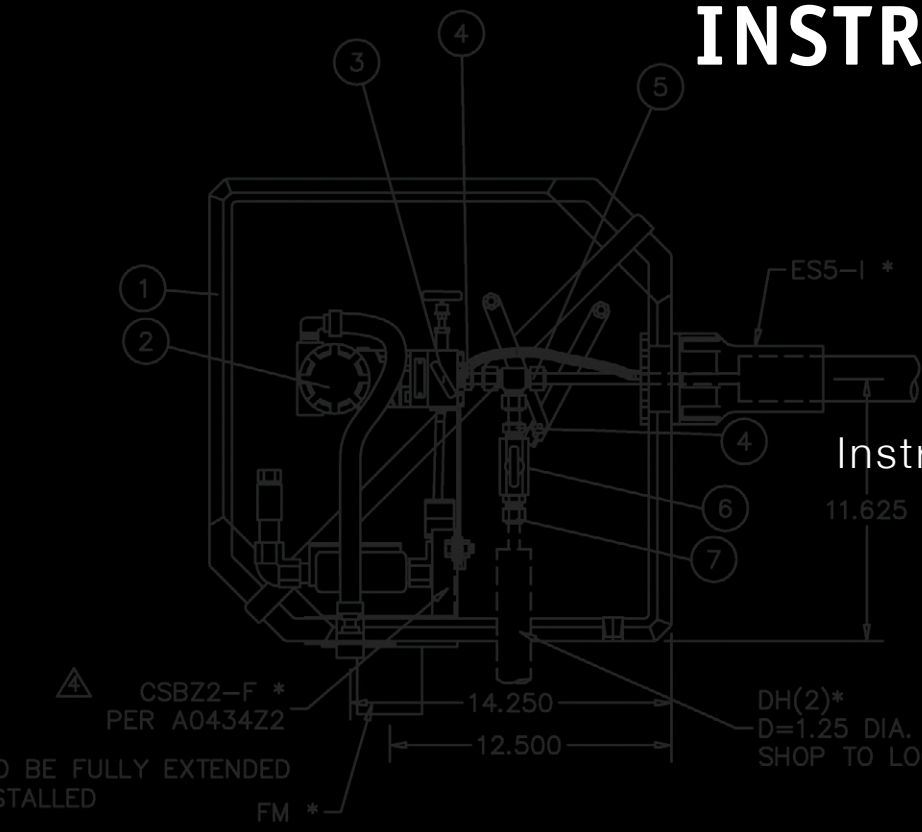

O'Brien - Integrated Solutions & Products for Instrumentation

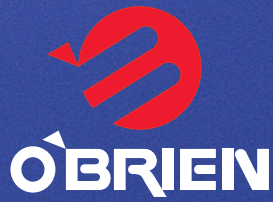

As process automation technology continues to evolve the integrity and accuracy of field installations become more critical. Process industries around the world have clearly identified that safety, yield, scrap, and compliance are directly associated with the integrity and reliability of the instrumentation and analyzer loops. Environmental protection of field devices is often an overlooked and misunderstood component.

For over 50 years O'Brien has provided customers with world class, engineered products and best practice solutions for field instrument installations. Our expertise is heat transfer and process accuracy of instrumentation. Whether your application requires temperature maintenance, freeze or environmental protection, O'Brien has a solution.

TRACEPAK and STACKPAK tubing bundles, VIPAK, HEATPAK and FLEXPAK heated instrumentation enclosures and SADDLEPAK instrument mounting systems are best in class products. From design and project support to installation, the O'BrienSERVICES team provides turnkey solutions for the most demanding applications throughout the world.



- ▶ **VIPAK®** ABS and GRP heated instrument enclosures and sun shades.
- ▶ **O'BrienSERVICESSM** design, installation and field support provide a warm loop guaranty.
- ▶ **TRACEPAK®** and **STACKPAKTM** insulated and heated instrument impulse and analyzer sample transport lines.
- ▶ **SADDLEPAK®** modular instrument support system.
- ▶ **HEATPAK®, FLEXPAK®** partial enclosures for field instruments.
- ▶ **S-LINE®** insulated personnel protection tubing.
- ▶ **J-LINE®** and **TRACEPAK® MJ** jacketed and corrosion control tubing.

Sample Transport Lines

Heated and unheated lines for process or emissions analyzers. Combined with TrueTube®, TRACEPAK and STACKPAK will maintain uniform temperatures insuring that a representative sample reaches the analyzer.



Sample Cabinets

VIPAK thermoformed and welded stainless steel sample cabinets insulated or uninsulated.



Sample Cabinet Heaters and High Purity Tubing

Hazardous area heaters maintain sample cabinets at temperatures up to 110°C. Electropolished and SilcoNert™ 2000 coated TrueTube provide excellent performance when used to interconnect sample conditioning components.

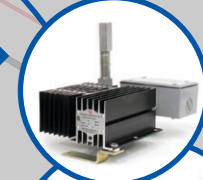

TRACEPAK Capillary Systems

CAPPAK™ insulated and electrically heated flexible capillary lines reduce the major source of error and sluggish response of diaphragm sealed instrumentation. It is available as an OEM option from leading instrument suppliers.

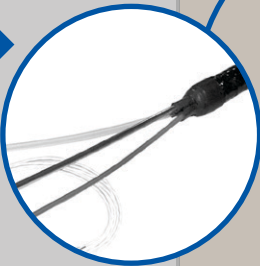

Flange Mounted Enclosures

With the O'Brien flange mount bracket VIPAK enclosures can be directly mounted and supported by the process flange for direct mount transmitters.



Instrument Enclosures

VIPAK enclosures are available in ABS and GRP composites. An integral polyurethane foam layer provides insulation. Enclosures are available in a variety of styles and sizes for one to five instruments.



Instrument Enclosure Heaters

Approved for use in hazardous and general purpose/safe areas O'Brien has a wide range of electric and steam heaters that provide freeze protection and temperature maintenance for field mounted instrumentation.



Close Coupled Instrument Enclosures

HEATPAK, HEATPAK II and FLEXIBLE HEATPAK are small lightweight enclosures that protect the process wetted portion of the transmitter from freezing cold.

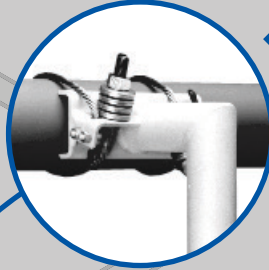

Cable Mounted Process Line Instrument Supports

SADDLEPAK cable mounts fit any line from 3 - 36" in diameter providing secure stable mounting for close coupled pressure and flow transmitters. The modular design allows it to be field configured for any installation.

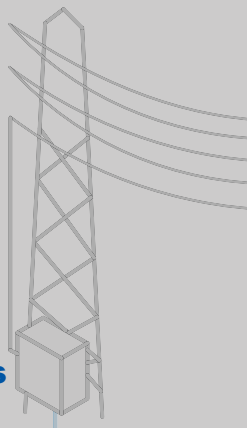

Custom Mounting Configurations

On-line mounting brackets are part of the VIPAK system to make winterizing process instruments easy regardless of how they are mounted.

Insulated and Heated Gage Covers

GAGEPAK and FLEXIBLE GAGEPAK covers provide insulation and heating for 100 mm, 4" and 6" dial stem mounted process gages.



Jacketed Tubing

J-Line and Tracepak MJ jacketed and corrosion control tubing are used wherever an extra measure of protection is needed from corrosive environments or wind blown dust and sand.

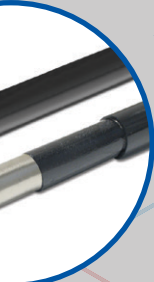

Steam/Electric Traced Instrument Impulse Lines

TRACEPAK tubing bundles provide the economical and maintenance-free solution for installation and protection of instrument impulse lines. Designed for freeze protection, temperature maintenance and high temperature process blow down.

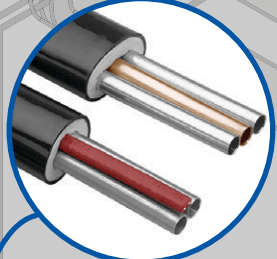

Instrument Stands

SADDLEPAK modular instrument stands can be as simple as a pipe stand or as complex as a multi transmitter rack mount. Specialized components are available for mounting to columns, beams and process lines.

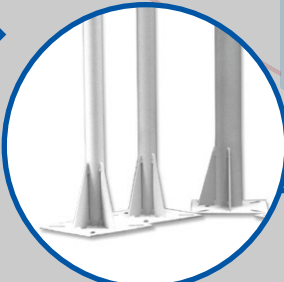

Insulated Tubing

S-LINE insulated tubing is an economical choice for small diameter lines that need to be insulated and weatherproofed to provide personnel protection or energy conservation of steam supply and condensate return lines.

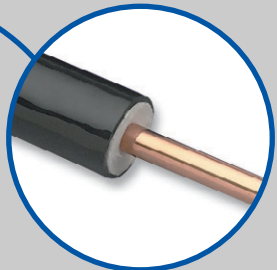

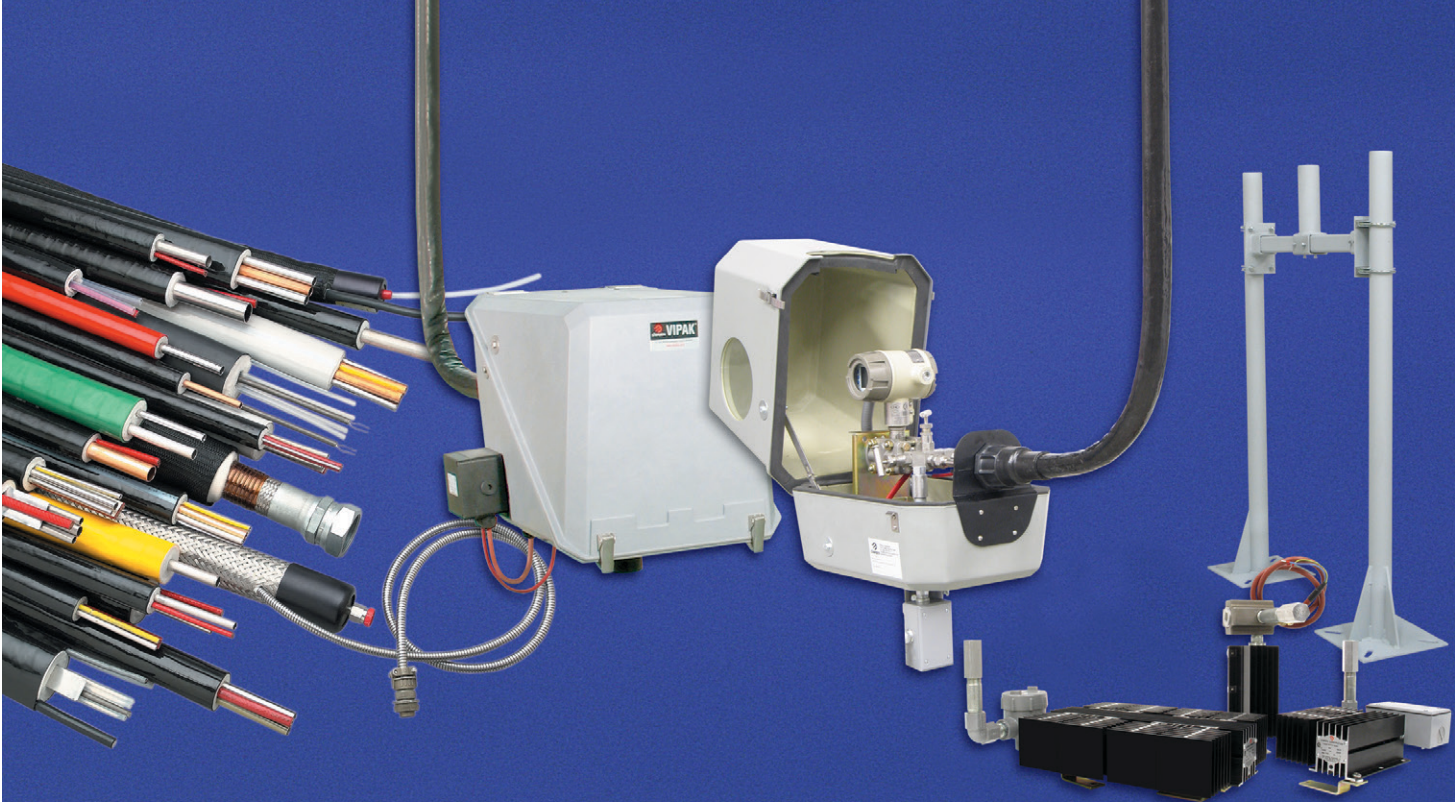

TRACEPAK® Tubing Bundles

O'Brien TRACEPAK and STACKPAK tubing bundles utilize electric, steam and recirculated fluid heaters to assure temperature maintenance for instrument impulse and sample transport lines in hazardous areas and general purpose or safe areas.

Process tube material is chosen to meet your plant piping standards and include welded and seamless 316SS as well as many other tube materials and finishes such as silica coated and electropolished. Metric and fractional sizes are available in any wall thickness.

VIPAK® Instrument Enclosures

O'Brien VIPAK instrument enclosures are available in SS, ABS and GRP versions both insulated and uninsulated. VIPAK is the first enclosure system to be designed and created to protect field mounted process instrumentation.

Exterior supports are available for mounting enclosures to walls, pipe stands, columns, process lines, and process flanges. Interior brackets provide a wide variety of direct support for the instruments, manifolds and piping that need protection.

Combined with our hazardous area heaters the VIPAK enclosure system provides a complete best practices solution.

SADDLEPAK® Instrument Supports

O'Brien SADDLEPAK is a modular support system for field-mounted instrumentation. It is easily assembled to create or duplicate any mounting detail.

Hazardous Area Heaters

O'Brien T-Series heaters are approved for use in hazardous and general purpose or safe areas. Available with integral thermostats or for connection to an existing controller these heaters are approved to maintain temperatures up to 110C with a maximum of 600 watts per unit. Choose NEC, CSA, ATEX and GOST approvals. Steam systems are also available.



www.obcorp.com



O'BrienSERVICESSM

Instrument winterization typically involves an inefficient and expensive combination of designs, products and crafts with little incentive to work together. Miscommunications surrounding instrument loops (engineering, design, procurement, materials management and installation) are a root cause of significant wasted man-hours, materials and change orders on most projects.

The O'BrienSERVICES Team eliminates costly confusion and variability between electrical, instrument, mechanical, insulation and heat tracing crafts to provide a warm loop guaranty. Our 50 years of industry leadership consistently delivers integrated solutions, which improve process accuracy.

- ▶ Design Optimization
- ▶ Applications Engineering
- ▶ Materials Management
- ▶ Installation Services
- ▶ Packaging & Logistics
- ▶ Field Support

ISO 9001

Certified to current ISO 9001 standards.

O'Brien's adherence to internationally recognized quality systems is your strongest assurance of our commitment to quality.

Customer Service

O'Brien is recognized for customer oriented solutions.

Our world-class customer service provides:

- responsive, knowledgeable personnel
- unparalleled delivery service
- dependable, tested results of all product lines
- on-line order status and shipment tracking.

USA • BELGIUM • CHINA • SINGAPORE

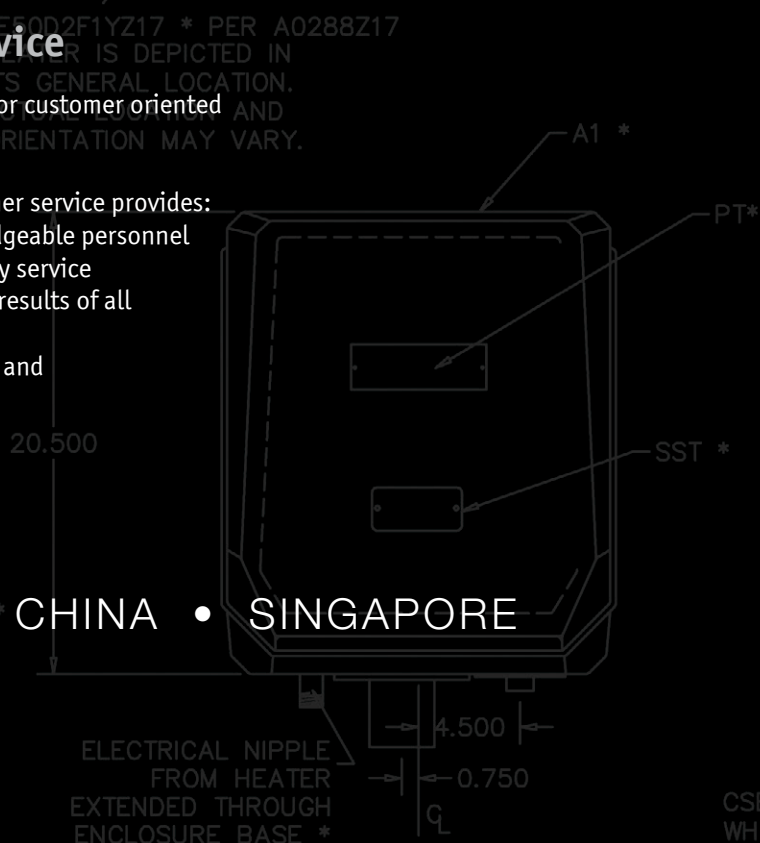

Specifications subject to change without notice.

©2013, by AMETEK, Inc. All rights reserved • QLT-OBIBR • 20 MAY 2013



USA • BELGIUM • CHINA • SINGAPORE
sales.obrien@ametek.com • www.obcorp.com

