

Complete monitoring system for the automatic, continuous measurement of the conductivity before (specific / total conductivity) and after a cation exchanger with electro deionization (acid / cation conductivity).

Calculation of the sample pH value and alkalizing reagent concentration based on differential conductivity measurement.

Monitor AMI CACE

Complete system mounted on stainless steel panel:

- **Transmitter AMI CACE** in a rugged aluminum enclosure (IP 66).
- **Swansensor UP-Con1000-SL**; two 2-electrode conductivity sensors with slot-lock design and integrated Pt1000 temperature probe, $k = 0.04 \text{ cm}^{-1}$.
- **Flow cell Catcon-Plus-SL CACE** made of stainless steel 316L with digital sample flow meter. Quick sensor release with patented slot-lock design. EDI-Module with exchangeable sample chamber module and automatic deaeration.
- Factory tested, ready for installation and operation.

Specifications:

- Conductivity measurement range: 0.055 to 1000 $\mu\text{S/cm}$.
- Calculation of pH value in the range from pH 7.5 to 11.5 (VGB-directive 450L).
- Calculation of alkalizing reagent concentration, e.g. ammonia in the range from 0.01 to 10 ppm.
- Simultaneous measurement and display of both conductivities, pH, alkalizing reagent, sample temperature and sample flow.
- Temperature compensation preset for strong acids but wide range of others selectable for other sample conditions.
- Two current outputs (0/4 - 20 mA) for measured signals (3rd as option).



Order Nr.	Monitor AMI CACE	A-23.462.000
Option:	<input type="checkbox"/> 3 rd current signal output (0/4 – 20mA)	A-81.420.050
	<input type="checkbox"/> Profibus DP & Modbus RTU interface (RS-485)	A-81.420.020
	<input type="checkbox"/> USB interface	A-81.420.042
	<input type="checkbox"/> HART interface	A-81.420.060
Option:	<input type="checkbox"/> Inlet filter	
Option:	<input type="checkbox"/> Backpressure Regulator	

Conductivity Measurement

Swansensor UP-Con1000-SL with integrated Pt1000 temperature probe.

Measuring range **Resolution**
0.055 to 0.999 µS/cm 0.001 µS/cm
1.00 to 9.99 µS/cm 0.01 µS/cm
10.0 to 99.9 µS/cm 0.1 µS/cm
100 to 1000 µS/cm 1 µS/cm
Automatic range switching.

Accuracy
± 1 % of measured value or ± 1 digit (whichever is greater).

Temperature compensation
Strong acids or non-linear function for high purity water, neutral salts, strong bases, ammonia, ethanolamine, morpholine, linear coefficient in %/°C, absolute (none). Influence of temperature see PChem2012 14(7) [Wagner]

pH and alkalinizing reagent calculation
Ranges (25° C): pH 7.5 to 11.5
e.g. ammonia 0.01 to 10 ppm

Temperature measurement Pt1000
Measuring range: -30 to +130 °C
Resolution: 0.1 °C

Sample flow measurement
With digital SWAN sample flow meter

Electrical Connection Scheme

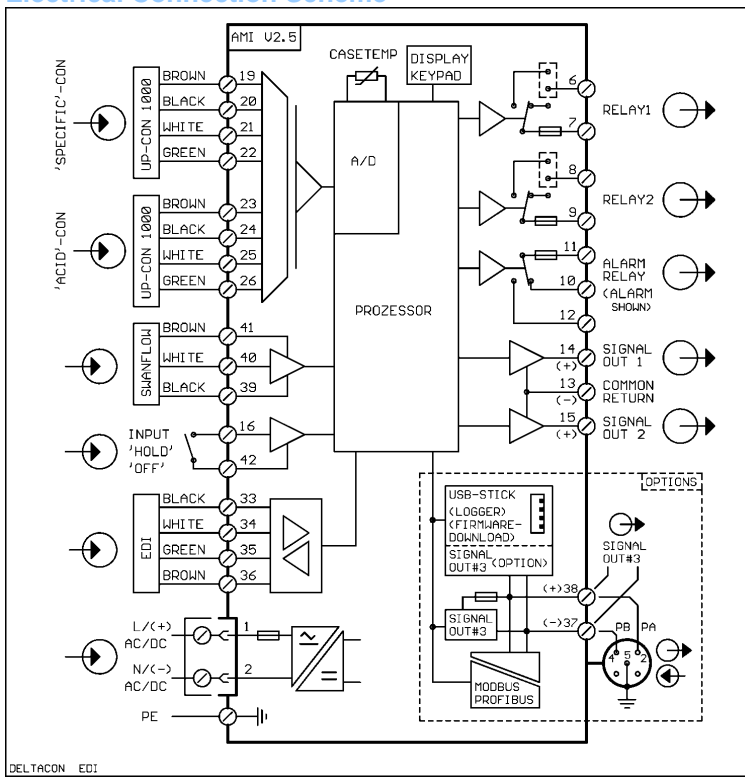

Transmitter Specifications and Functionality

Electronics case: Cast aluminum
Protection degree: IP 66 / NEMA 4X
Display: backlit LCD, 75 x 45 mm
Electrical connectors: screw clamps
Dimensions: 180 x 140 x 70 mm
Weight: 1.5 kg
Ambient temperature: -10 to +50°C
Humidity: 10 - 90% rel., non-condensing

Power supply
Voltage: 100 - 240 VAC (± 10 %),
50/60 Hz (± 5 %)
or 24 VDC (± 10 %)
Power consumption: max. 30 VA

Operation
Easy operation based on separate menus for "Messages", "Diagnostics", "Maintenance", "Operation" and "Installation". User menus in English, German, French and Spanish.

Separate menu specific password protection.

Display of process value, sample flow, alarm status and time during operation. Storage of event log, alarm log and calibration history.

Storage of the last 1'000 data records in logger with selectable time interval.

Safety features
No data loss after power failure, all data is saved in non-volatile memory. Overvoltage protection of in- and outputs. Galvanic separation of measuring inputs and signal outputs.

Transmitter temperature monitoring with programmable high/low alarm limits

1 Alarm relay
One potential free contact for summary alarm indication for programmable alarm values and instrument faults.
Maximum load: 1A / 250 VAC

1 Input
One input for potential-free contact. Programmable hold or remote off function.

2 Relay outputs
Two potential-free contacts programmable as limit switches for measuring values, controllers or timer for system cleaning with automatic hold function.
Rated load: 1A / 250 VAC

2 Signal outputs (3rd as option)
Two programmable signal outputs for measured values (freely scalable, linear or bilinear) or as continuous control outputs (control parameters programmable) as current source. 3rd signal output selectable as current source or current sink.
Current loop: 0/4 - 20 mA
Maximum burden: 510 Ω

Control functions
Relays or current outputs programmable for 1 or 2 pulse dosing pumps, solenoid valves or for one motor valve. Programmable P, PI, PID or PD control parameters.

1 Communication interface (option)
RS485 interface (galvanically separated) with Fieldbus protocol Modbus RTU or Profibus DP / 3rd Signal output / USB interface.

Monitor Data

Sample conditions
Flow rate: 3 to 4 L/h
Temperature: up to 50 °C
Inlet pressure (25 °C): 0.5 bar
Outlet pressure: pressure free
No sand, no oil

EDI Capacity:
SC_{max} = 40µS/cm as NH₄OH
SC_{max} = 350µS/cm as NaOH

The use of SWAN Back Pressure Regulator is highly recommended. Particle filtration recommended in case of high iron concentration.

Conditions for pH calculation
Only 1 alkalinizing reagent, contamination is mostly NaCl, phosphates < 0.5 mg/L, if pH value < 8 the concentration of contamination must be small compared to alkalinizing reagent.

Sample connections
Inlet: Swagelok ¼" tube adapter
Outlet: G ½" adapter for tube
for flexible tube Ø 20 x 15 mm

Panel
Dimensions: 280 x 850 x 200 mm
Material: stainless steel
Total instrument weight: 10.0 kg