



Combics Complete Scales High Resolution CAH...



- Large choice of combination options with standard components
- High weight-bearing construction together with high display accuracy
- High IP protection up to IP67
- Easy to operate
- Various interfaces RS232, RS485 | 422, analog, DIO, Profibus, Ethernet
- Internal motorized calibration weight
- We provide certificates and documentation according to GMP, ISO, ATEX, OIML and FDA regulations

Combics provides support in all areas of your process chain, from manual formulations up to PC controlled production checks.

The modular system allows for a tailor-made configuration of the individual components for each area. We also produce individual complete solutions according to your specific applications.

Based on the specific requirements of various industries and the basic legal conditions, Sartorius has developed intelligent solutions for all weighing applications, from incoming goods through to production on a large technical scale. The Combics series supports the production of high-quality, appealing and safe products.

The unrivalled precision of Combics helps

- control flexible production
- reduce costs
- improve product quality
- raw materials to be used optimally
- increase output

A design made for longevity and flexibility stands for reliability.

The hygienic design of our solutions complies with today's extremely important hygiene regulations without compromise. The devices can be cleaned very easily and thus allow Combics to be used under tough conditions or where stringent safety standards apply. The materials and surfaces used significantly contribute to minimizing contamination risks.

The easy to operate concept, in combination with the clearly labeled keys, helps prevent errors and makes it simpler for new users to learn how to use the scales.

The intelligent software guarantees optimum support in logging and documenting data. Comprehensive interfaces to data management systems and process controls allow optimum integration.

Typical weighing applications are supported by diverse software applications.

Additionally, we support you by qualifying according to your requirements. We provide certificates and documentation according to GMP, ISO, ATEX, OIML and FDA regulations.

General Specifications

Combination options

2 display and service units
5 weighing ranges from 16 kg to 300 kg
3 platform dimensions

Material

Display unit stainless steel
Platform
Industry compatible epoxide resin coating
Color: NCSS3502-B (RAL7040), or
galvanized steel
Stainless steel load plate

Display and control unit

Delivered optionally with screw-fixed sheet
metal plate or column for fixing the device
to the platform

Additional accessories

4 × height-adjustable feet
Leveling device
Overload protection

Operating temperature range

0 (+10)°C to 40°C

Resolution (non-verifiable)

Up to 640.000 d

Resolution (verifiable, Class III)

Depends on model: up to 34,000 e

Weighing system

Monolytic measuring system,
with integrated motorized calibration weight

IP protection rating

Platform IP44, IP65 or IP67
Display and control unit IP69K

Data Interfaces

RS232

Optional

RS232

RS485/422

Analog output 0/4..20 mA, 0-10 V, 16-bit

Digital I | O (5 inputs and 5 outputs)

Profibus DP

Ethernet TCP | IP

PS/2

2nd inbuilt A | D converter

Built-in Alibi memory

Optional

130,000 data records

Comprehensive range of accessories

Pit installation

Roller conveyor

Benches

Power supply

100 – 240 V AC (–15% | +10%), 50 – 60 Hz,
max. 17 W | 23 VA

Optional

15.5-24 VDC (±10%), max. 12 W

13–17 VAC (±10%), 50 – 60 Hz, max. 12 W

Battery operation

Optional

Internal rechargeable battery in indicator
housing
(different housing dimensions)

Interference emission

Acc. to EN 61326-1, Class B (IEC 61326-1)

Electrical safety

Acc. to EN 61010-1 (IEC 61010-1)

EN60950 (IEC950)

Interference immunity

Acc. to EN 61326-1,
industrial areas (IEC 61326-1)

Applications	Material Design		Weighing capacity (kg)	Platform dimensions mm Order code	Resolution
CAH1	E	-	34	ED -	H

Example of order code CAW1P1-60FE-L:

Part 1:	CAH1	Display and Operating Terminal:	Application: Weighing only
Part 2:	E-34ED	Platform:	34 kg, L = 400 mm × B = 300 mm
	-H	Resolution:	0.1 g readability, non-verifiable

Display and control unit (Part 1)



Application levels

	Combiics 1	Combiics 3
Keyboard	6 keys	30 keys alpha numerical keypad
Display	14 segments 20 mm weight display	Graphics 20 mm weight readout plus application icons

Applications

Basic weighing	•	•
Data transfer to printer PC	•	•
ISO test	•	•
Counting		•
Weighing in percent		•
Averaging		•
Checking Classification		•
Totalizing		•
Combination of 3 applications		•
Weighing and counting to target value (from the memory)		•
SQ Min	•	•
Identifiers		•
Product data memory		•
Date Time		•
Integrated red green yellow display		•
Built-in Alibi memory (optional)		○

Platform (Part 2)

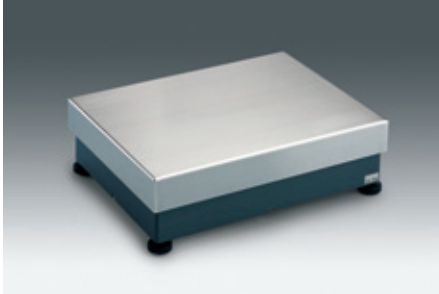

Order code weighing capacity		E-16ED	E-16ED	E-34ED	E-34ED
Order code resolution		-H	-HCE	-H	-HCE
Weighing capacity max.	kg	16	16	34	34
Readability	g	0.1	0.1	0.1	0.1
Accuracy class		-	II	-	II
Verification scale interval e	g	-	1	-	1
Min. load min	g		5		5
Electrical compensated preload (without limitation of the weighing capacity)	kg	4	4	4	4
Max. initial load	kg	16	16	18	18
Repeatability	≤ ± g	0.05	0.05	0,1	0,1
Linearity	≤ ± g	0.2	0.2	0.2	0.2
Max. weight bearing capacity	kg	130	130	130	130
Platform dimensions (B × T × H)	mm	400 × 300 × 120	400 × 300 × 120	400 × 300 × 120	400 × 300 × 120
Net weight, approximate	kg	16	16	16	16
Operating temperature range*	°C	+10 ... +30	+10 ... +30	+10 ... +30	+10 ... +30
Ambient temperature range	°C	0 ... +40	0 ... +40	0 ... +40	0 ... +40
IP protection		IP65	IP65	IP65	IP65

Platform (Part 2)

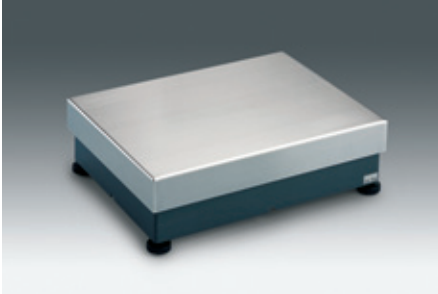

Order code weighing capacity		E-64ED	E-64ED	E-64ED
Order code resolution		-S	-SCE	-H
Weighing capacity max.	kg	64	64	64
Readability	g	1	1	0.1
Accuracy class		-	II	-
Verification scale interval e	g	-	10	-
Min. load min	g		50	
Electrical compensated preload (without limitation of the weighing capacity)	kg	13	13	13
Max. initial load	kg	30	30	30
Repeatability	$\leq \pm$ g	0.3	0.3	0.1
Linearity	$\leq \pm$ g	0.5	0.5	0.3
Max. weight bearing capacity	kg	130	130	130
Platform dimensions (B x T x H)	mm	400 x 300 x 120	400 x 300 x 120	400 x 300 x 120
Net weight, approximate	kg	16	16	16
Operating temperature range*	°C	+10 ... +30	+10 ... +30	+10 ... +30
Ambient temperature range	°C	0 ... +40	0 ... +40	0 ... +40
IP protection		IP65	IP65	IP44

Dimensions

Display and control unit:

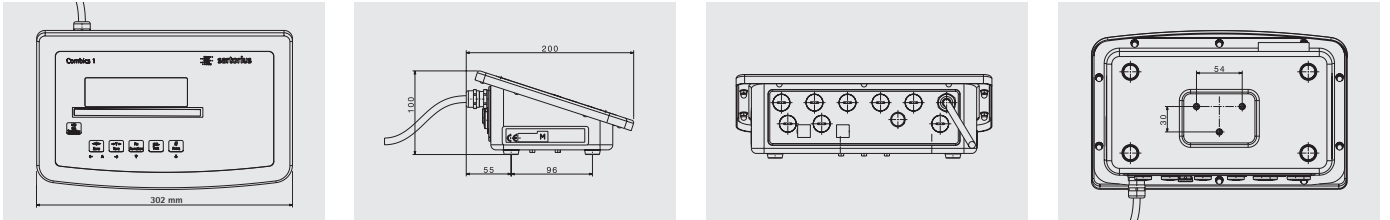

Platforms:

Model ED

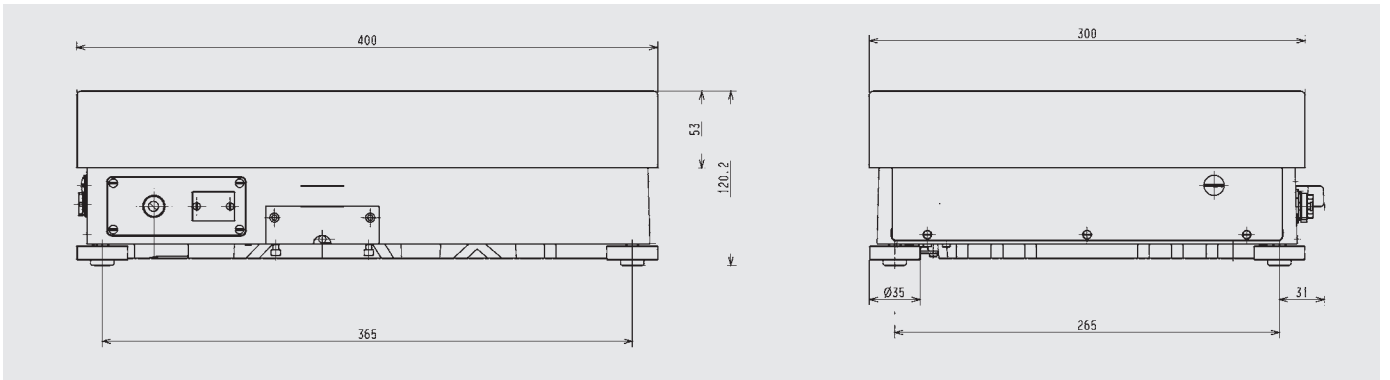

Model FE

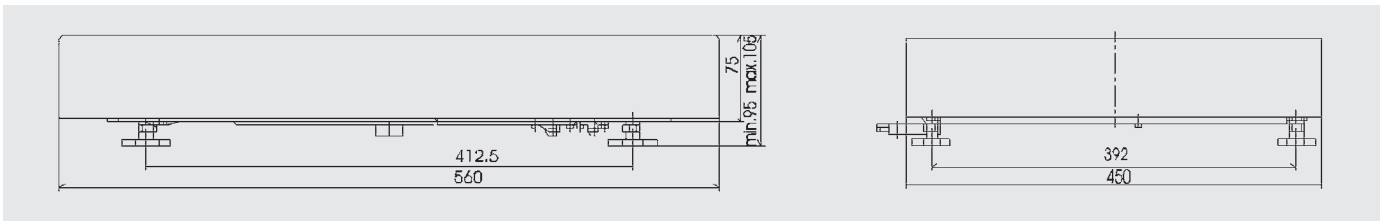

Model IG

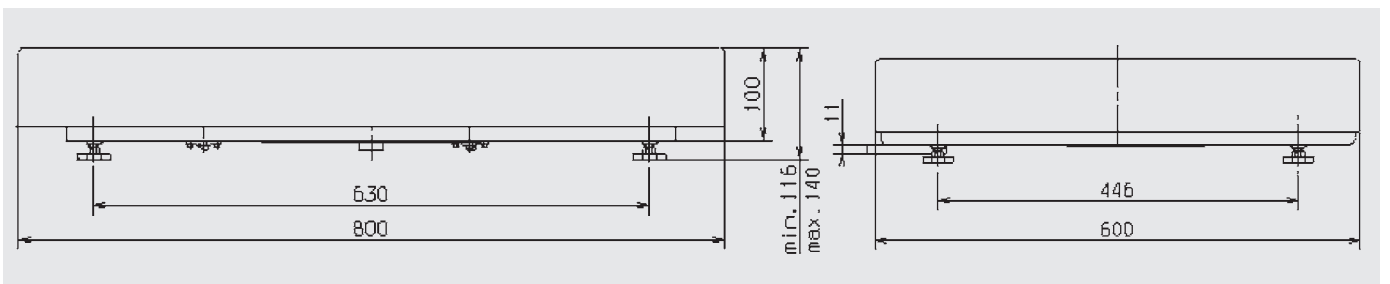

Options

The choice of many different options allows the scales to be customized to suit the user's specific applications. If the option code is given with the order, the scales are delivered with the required features. (Options can be retrofitted by ordering the respective accessories).

	Order number as option	Combics 1	Combics 3	Accessories Order number
Interfaces				
COM 1: RS 232		Standard	Standard	
COM 2: RS 232		-	Standard	
UNICOM				
RS 232	A1	•	•	YD002C-232
RS 422	A2	•	•	YD002C-485
RS 485	A3	•	•	YD002C-485
Digital 5 inputs 5 outputs	A5	•	•	YD002C-DIO
Analog output	A9	•	•	YD002C-AO
Profibus – DP	B1	•	•	YD002C-DP
Ethernet TCP IP	B9	•	•	YD002C-ETH
2nd weighing point Scale connection				
Analog platform 10,000e	A20		•	YDI02C-WPA
RS 232 interface for digital platform	A62		•	YDI02C-WPD
RS 485 interface for digital platform	A72		•	YDI02C-WPD
Equipment				
24-volt AC adapter	L8	•	•	
Built-in alibi memory	E 5		•	
ATEX zones 2 and 22 protection class	Y2	•	•	
Final inspection test report (scale)	Z3	•	•	

	Order number as option	Combics 1	Combics 3	Accessories Order number
Application kits for Combics 3 (instead of the above basic applications)				
Basic filling – Automatic single-component filling to target weight in filling or dispenser proportioning applications with transaction counter, totalizing and statistics functions	H3		•	
Filling with extras – like „Basic Filling“, but also includes: Filling optimization, material and container weight monitoring, data memory for 100 products	H4		•	
Combination of user programs: weighing, counting, neutral measurement, weighing in percent, animal weighing, checkweighing, classification (3 or 5 classes); totalizing; up to three applications can be combined with one another	I2		•	
Separable scale connection				
Separable plug-in connection between indicator WP2 and platform, socket on indicator (0.2 m), plug included separately	X6		•	
Cable for connecting 2nd scale				
Connection cable IS platform to digital interface WP2 – 12-pin round plug socket	M97		•	
Connection cable for EA EB LA CP to digital interface WP2 – 25-pin D-SUB plug	M98		•	
Connection cable for QA QC FB FC to digital interface WP2 – 12-pin round plug socket	M99		•	
Connecting cable	UNICOM	COM1	COM2 only for Combics 3	
Connection cable for barcode scanner YBR03FC, – 5-pin DIN socket, 1 m	M8	–	–	
Connection cable for printer YDP12 04IS, – 9-pin D-SUB plug, 6 m	M33	M3	M23	
Connection cable for printer YDP20-0CE or PC, – 9-pin D-SUB socket, 6 m	–	M9	–	
Connection cable for PC – 9 pin D-SUB socket	M34	M4	M24	
Connection cable for dig. Sartorius scales, – 25-pin D-SUB plug, 6 m	M32	M2	M22	
Connection cable for various accessories – 25-pin D-SUB socket	–	M1	–	
Connection cable for dig. Sartorius scales, – 12-pin round plug socket, 6 m	M35	M5	M25	
Connection cable for various accessories – 12-pin round plug socket	–	M6	–	
Connection cable for various accessories and IS platform, – 12-pin round plug socket, 6 m	M37	M7	M27	
Connection cable with open cable ends, 6 m	M12	–	M12	
Ethernet connection cable with RJ45 plug, 7 m	M38	–	–	

Accessories

Cables as accessories	Order number
Connection cable with cable gland for barcode scanner YBR03FC, open cable ends 5-pin DIN socket, 1 m	YCC02-BR02
Connecting cable with cable gland for accessories, open cable ends 25-pin D-SUB socket, 6 m	YCC02-D25F6
Connection cable with cable gland for dig. Sartorius scales, open cable ends 25-pin D-SUB plug, 6 m	YCC02-D25M6
Connection cable with cable gland for printer YDP20-OCE or PC, open cable ends 9-pin D-SUB socket, 6 m	YCC02-D09F6
Connecting cable with cable gland for printer YDP12 04IS, open cable ends 9-pin D-SUB plug, 6 m	YCC02-D09M6
Connection cable with cable gland for dig. Sartorius scales, open cable ends 12-pin round plug socket, 6 m	YCC02-R12M6
Connecting cable with cable gland for accessories and IS platforms, open cable ends 12-pin round plug socket, 6 m	YCC02-R12F6
Connecting cable with cable gland for various accessories, open cable ends open cable ends, 6 m	YCC02-RELAIS02
Connecting cable with cable gland for Ethernet with RJ45 plug on both ends, 7 m	YCC02-RJ45M7

Software

SNLE Sartorius Nice Label Express Software	YAD02IS
WinScale for Windows	YSW03
SartoCollect	YSC02

Printer

Data printer with date, time and statistics program	YDP20-OCE
Strip label printer, 60 mm paper width	YDP04IS-OCEUV
Strip label printer, 108 mm paper width	YDP14IS-OCEUV
Thermal transfer printer, 108 mm paper width	YDP14S-OCEUVTH

Other accessories

Barcode scanner	YBR03PS2
Control display Red Green Red	YRD14Z
Dust covers for display unit (2 pieces)	YDC01CI
Plug and socket set to connect similar weighing platforms to indicators (separable connection)	YAS99I
Cable gland for cables with diameter 4.5 to 9 mm, M16 × 1.5	YAS04CIS
Kit for control panel installation	YAS07CI
Junction box, stainless steel, to connect up to 4 load cells in one platform or for external assembly, PR6130 64S	940536130642
Relay box to connect scales to external control units, with 4 (5) relay outputs (250 V 3 A) and 1 optocoupler input (0 – 30 V)	YSB01
Digital input output module to connect Combics 3 to external control units, with 8 open collector outputs (50 mA) and 7 TTL-compatible inputs (0 – 30 V)	YSB02
Relay box to connect Combics 3 to external control units	VF3033

Description	Order reference
Mechanical accessories	
Brackets for wall mounting, stainless steel	YDH01CIS
Brackets for wall mounting, stainless steel, tiltable indicator	YDH02CIS
Painted floor-mounted column, height 1.1 m	YDH03CIP
Stainless steel floor-mounted column, height 1.1 m	YDH03CIS
Stainless steel floor-mounted column base (4 supports)	YBP03CIS
Mount for barcode scanner, to be attached to: floor-mounted column, bench stand, complete scale retainer	YBH01CWS
Painted roller conveyer for platform dimensions 400 × 300 mm	YRC01EDA
Stainless steel roller conveyer for platform dimensions 400 × 300 mm	YRC01EDS
Painted pit installation for platform dimensions 800 × 600 mm	YEG04IP
Stainless steel pit installation for platform dimensions 800 × 600 mm	YEG01IP
Installation kit for pit installation	YAS01IS
Painted roller conveyer for platform dimensions 800 × 600 mm	YRC01IGP
Stainless steel roller conveyer for platform dimensions 800 × 600 mm	YRC01IGS
Painted bench for platform dimensions 400 × 300 mm, adjustment range 645 – 685 mm	YWT01CWP
Stainless steel bench for platform dimensions 400 × 300 mm, adjustment range 645 – 685 mm	YWT01CWS
Painted bench for platform dimensions 800 × 600 mm, adjustment range 642 – 702 mm	YWT04CWP
Stainless steel bench for platform dimensions 800 × 600 mm, adjustment range 642 – 702 mm	YWT04CWS
Stainless steel bench support arm for attaching the indicator, adjustable height	YDH01WTCWS
Wheel set (2 wheels with steering and braking function) for bench	YRO01WTCW

Sartorius Weighing Technology GmbH
Weender Landstrasse 94-108
37075 Goettingen, Germany

Telephone +49.551.308.0
Fax +49.551.308.3289

info.mechatronics@sartorius.com
www.sartorius.com

Specifications subject to change without notice.
Printed in Germany.
Printed on paper bleached without chlorine. | W
Publication No.: WI-2003-e12074
Order No.: 98649-011-09