

# Model FT3 Thermal Gas Mass Flow Meter and Temperature Transmitter

For Industrial, Environmental,  
Energy Monitoring and Process  
Control Applications



**FOX**  
THERMAL INSTRUMENTS, INC.  
*Fox is ISO 9001 certified*

# Smart, Real-Time Mass Flow Measurement

The Fox Model FT3 measures two important process variables with a single instrument, providing isolated 4 to 20 mA and pulse outputs for flow rate, and a 4 to 20 mA pulse output for process gas temperature or a second flow rate output.

Direct mass flow measurement, exceptional low-flow sensitivity, fast response, and low maintenance requirements distinguish the Fox Model FT3. Virtually immune to changes in temperature and pressure, the flow meter delivers repeatable, accurate mass flow measurement under varying loads. It's rugged, no-moving-parts design is also ideal for high-vibration industrial environments, and enhanced EMI immunity makes it suitable for environments where electric motors, ignitors or dirty power may affect instrument performance.

## CAL-V™ Performs Calibration Validation in your Pipe

The Model FT3's CAL-V™ feature is an in-situ calibration routine that validates the flow meter's calibration accuracy by testing the functionality of the sensor and its associated signal processing circuitry. This innovative approach lets you validate instrument calibration in your pipe, at your process conditions,

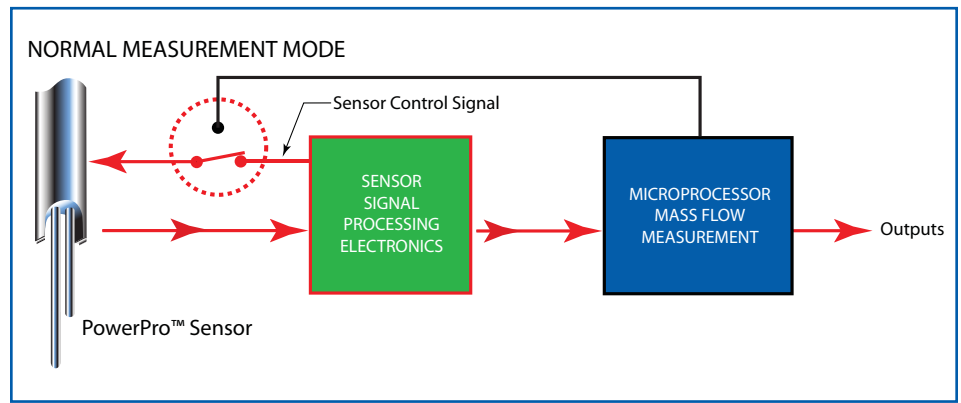

In normal measurement mode the signal processing electronics control the sensor.

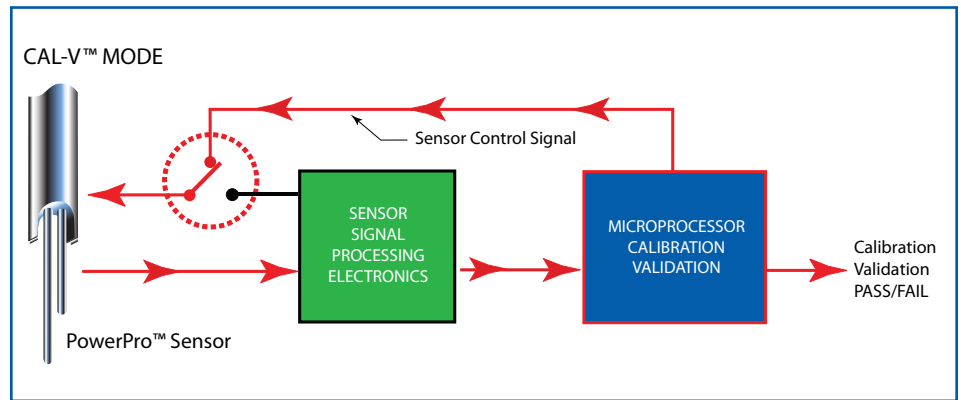

In CAL-V™ mode, the microprocessor controls the sensor and determines the resulting electrical characteristics.

with just a push of a button. At the conclusion of the test, the meter will display a pass/fail message and the CAL-V™ data is saved in the meter for look-up at any time.

During the test, the meter's microprocessor adjusts the signal to the sensor elements and determines the resulting electrical characteristics. These site-determined characteristics

are compared with the data that was collected and stored in the instrument electronics during original factory calibration. Matching data within established tolerances confirms the meter is measuring accurately.

CAL-V™ is an operator-initiated test that can be performed at any flow rate, including zero, and is completed in just three to four minutes. CAL-V™ can be initiated from the front panel, USB connection, RS485 Modbus or HART. If CAL-V™ is initiated by Fox's FT3 View™ software tool, a calibration validation certificate can be produced at the conclusion of the test.

This feature is of particular value in environmental monitoring applications where periodic calibration validation is mandated. It can also be used to

CALIBRATION VALIDATION: Typical Requirements of Competitive Models	Other Thermal Flow Meters	Fox FT3 with CAL-V™
Stop the flow	Required	Not Required
Remove meter from pipe		
Disconnect wires from flow meter		
Look up data on flow meter's calibration certificate		
Measure electrical characteristics with volt ohm meter		
Perform calculations to evaluate flow meter performance		
Set process pressure to manufacturer's calibration pressure		
Connect auxiliary test equipment and/or test gases to flow meter		



Built-in flow conditioning improves measurement accuracy in space-constrained applications.

streamline quality assurance, improve process initiatives and apply scheduled maintenance procedures.

### Rugged, Reliable Performance

The Fox PowerPro™ sensor operates at a higher power level than competitive thermal flow sensors resulting in improved response time and wider turndown. The PowerPro™ sensor also provides exceptional accuracy at high velocities - up to 60,000 SFPM (280 NMPS).

The Model FT3 features a dual-compartment, explosion-proof electronics enclosure. One compartment houses the instrument electronics and the second compartment is accessible for your wiring terminations. A waterproof seal between the compartments helps prevent moisture damage and maintain the integrity of the instrument electronics.

An optional on-board 2 line x 16 character backlit display is available to view flow rate, total flow, elapsed time, process gas temperature and alarms.

The display is also used in conjunction with the Configuration Panel for field configuration of flow meter settings such as 4 to 20 mA and pulse output scaling, pipe area, zero flow cutoff, flow filtering or damping, display configurations, diagnostics and alarm limits. Optically activated keys provide interface to the flow meter without removing the cover.

The Model FT3 features galvanically-isolated outputs and enhanced EMI immunity. A variety of meter configurations, materials, process

Model FT3, and Fox's free FT3 View™ software provides complete configuration and remote process monitoring functions. FT3 View™ lets you adjust meter configuration, evaluate transmitter alarm conditions, collect process data, and view measurements from your PC or control station. HART and RS485 Modbus are available options. All digital communication is isolated to provide immunity from electrical interference.

### NIST Traceable Factory Calibration

Fox calibrations are performed with NIST

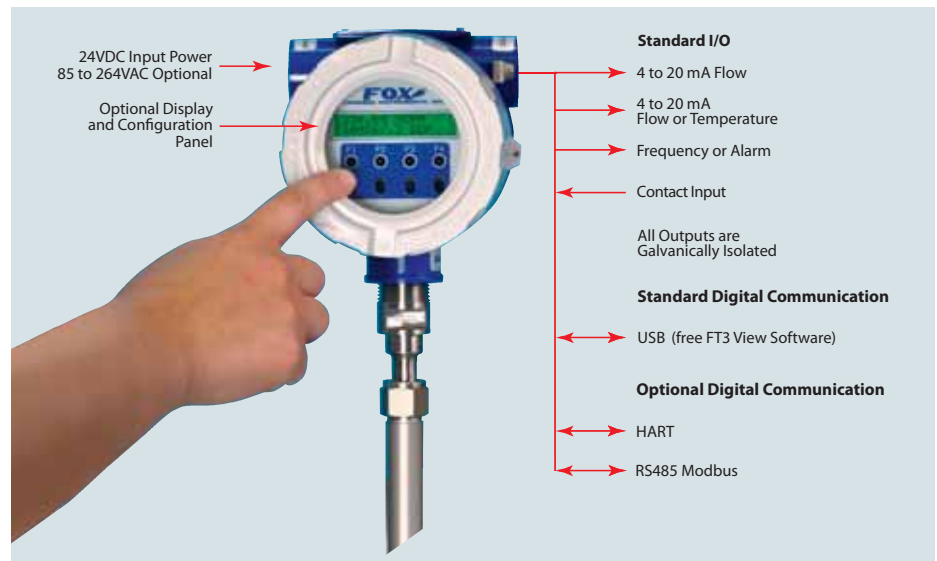

connections and output options offer improved design flexibility, lower cost-of-ownership and enhanced control capabilities.

The Model FT3 is available in both insertion and inline models. The insertion meter is easily installed with a weld-o-let and compression fitting. The inline model is available in ¼-inch to 6-inch sizes and includes built-in flow conditioners that eliminate the need for long, straight pipe runs.

### Communications Options

A USB connection is standard on the

traceable flow standards. Whether you require a straightforward air calibration or a complex mixed gas calibration, our goal is to achieve the highest accuracy and the fastest turnaround time. The Fox Calibration Lab employs a wide range of gases, gas mixtures, temperatures, pressures and line sizes to simulate actual fluid and process conditions. This real-world approach improves installed accuracy and minimizes measurement uncertainty.





# Summary Specifications

## Performance Specs

### Flow Accuracy:

Inline meter:  $\pm 1\%$  of reading  $\pm 0.2\%$  of full scale. 8 diameters of straight, unobstructed pipe upstream and 4 downstream required.  
 Insertion meter:  $\pm 1\%$  of reading  $\pm 0.4\%$  of full scale. 15 diameters of straight, unobstructed pipe upstream and 10 downstream required.

**Flow Repeatability:**  $\pm 0.2\%$  of full scale

**Flow Response Time:** 0.9 seconds (one time constant)

### Temperature Accuracy:

$\pm 1.8^\circ\text{F}$  ( $\pm 1.0^\circ\text{C}$ ) -40 to 250°F (-40 to 121°C);  $\pm 3.6^\circ\text{F}$  ( $\pm 2.0^\circ\text{C}$ ), 250 to 650°F (121 to 343°C); 60 SFPM minimum.

### Calibration:

Factory Calibration to NIST traceable standards  
 CAL-V™: In situ, operator-initiated calibration validation

## Operating Specs

### Units of Measurement (field selectable):

SCFM, SCFH, NMPS, NM3/M, NM3/H, NM3/D, NLPS, NLPM, NLPH, MCFD, MSCFD, SCFD, MMSCFD, MMSCFM, SMPS, SM3/H, LB/S, LB/M, LB/H, LB/D, KG/S, KG/M, KG/H, SLPM, SFPM, MT/H

### Flow Rates for Insertion Flow Meter:

15 to 60,000 SFPM (0.07 to 280 NMPS) - Air at 70°F (20°C) & 1 ATM  
 Turndown: up to 1000:1; 100:1 typical

Typical Flow Ranges for Insertion Flow Meters		
Pipe size	SCFM	NM <sup>3</sup> /HR
1.5" (40mm)	0 - 840	0 - 1,320
2" (50mm)	0 - 1,400	0 - 2,200
3" (80mm)	0 - 3,080	0 - 4,860
4" (100mm)	0 - 5,300	0 - 8,360
6" (150mm)	0 - 12,000	0 - 18,900
8" (200mm)	0 - 20,800	0 - 32,800
12" (300mm)	0 - 46,600	0 - 73,500

Flow Ranges for Inline Flow Meters		
Pipe size	SCFM	NM <sup>3</sup> /HR
0.25"	0 - 20	0 - 32
0.5"	0 - 90	0 - 140
0.75"	0 - 180	0 - 280
1"	0 - 320	0 - 500
1.25"	0 - 580	0 - 910
1.5"	0 - 840	0 - 1,320
2"	0 - 1,400	0 - 2,200
2.5"	0 - 2,000	0 - 3,150
3"	0 - 3,080	0 - 4,860
4"	0 - 5,300	0 - 8,360
6"	0 - 12,000	0 - 18,900

Note: Standard conditions of air at 70°F and one atmosphere. Consult factory for other gases and for flow ranges above those listed. Inline meters above 5,000 SCFM (7,900 NM<sup>3</sup>/H) air may require third party Calibration. Contact Fox.

### Gas Pressure (maximum):

Insertion: 500 psig (34.5 barg)

Inline (1/4" - 6"): NPT 500 psig (34.5 barg); 150# flange 230 psig (16 barg)  
 Check with factory for higher pressure options.

Note: Pressure ratings stated for temperature of 100°F (38°C).

### Relative Humidity:

90% RH maximum; non-condensing

### Temperature:

ST sensor: -40 to 250°F (-40 to 121°C)

HT Sensor: 32 to 650°F (0 to 343°C)

### Enclosure:

Without display or AC power supply: -40 to 158°F (-40 to 70°C)

With display and/or AC power supply: -4 to 158°F, (-20 to 70°C)

Remote sensor junction box: -76 to 212°F (-60 to 100°C)

### Input Power:

24 VDC,  $\pm 10\%$ , 0.75 amp standard; 85 to 264VAC 47-63Hz, 20 watts optional.

### Outputs:

Two isolated 4 to 20 mA outputs (one for flow rate; the second is programmable for flow rate or temperature); fault indication per NAMUR NE43;  
 Isolated pulse output 0 to 100Hz, 5 to 24 volts p/p for flow (the pulse output can be used as an isolated solid state output for alarms); 10mA max.

USB connector for connecting to a computer is standard; free PC-based software tool - FT3 View™ - provides complete configuration, remote process monitoring and data logging functions.

Optional isolated communication outputs: HART and RS485 Modbus.

### 4 to 20mA Loop Verification:

Simulation mode used to align 4 to 20mA output with the input to customer's PLC/DCS.

## Physical Specs

### Sensor Material:

316 stainless steel standard; Hastelloy C276 optional

### Enclosure:

NEMA 4X (IP68), Aluminum, dual conduit entries with 3/4" NPT or optional M20 x 1.5mm. Cabling to remote enclosure: 5-conductor, 18 AWG, twisted, shielded, 100 feet maximum.

### Retractor Assemblies:

Packing gland assembly: 125 psig (8.6 barg.) max.

High pressure (crank) retractor: NPT 600 psig (41.4 barg), ANSI 150 flange & ANSI 300 flange, no valve supplied.

### Insertion Flow Meter Installation:

Fox-supplied compression fitting connects to customer-supplied 3/4" female coupling welded to pipe.

## Agency Approvals

### FM/FMc: (pending)

Explosion proof for Class I, Div. 1, Groups B, C, D; Non-incendive for Class I, Div. 2, Groups A, B, C, D; and Class II & III, Div. 1, Groups E, F, G. Indoor/outdoor, NEMA 4X.

### ATEX Directive 94/9/EC: (pending)

Zone 1: II 2 G Ex d IIC T6; -20C>Ta>70C; II 2 D Ex tb IIIC IP68 T90°C...300°C  
 Zone 2: II 3 G Ex nA IIC T6; -20C>Ta>70C (24VDC power only)

### IECEx: (pending)

Zone 1: II 2 G Ex d IIC T6; -20C>Ta>70C IP68, II 2 D Ex tb IIIC IP68 T90°C...300°C  
 Zone 2: II 3 G Ex nA IIC T6; -20C>Ta>70C (24 VDC power only)

### CE: Approved

EMC Directive; 2004/108/EC

Emissions and immunity Testing: EN61326-1:2008

**Dimensions:** [www.foxthermalinstruments.com/all-dimensions.php](http://www.foxthermalinstruments.com/all-dimensions.php)



**FOX**  
 THERMAL INSTRUMENTS, INC.

399 RESERVATION ROAD

MARINA, CA 93933

PHONE: 831-384-4300

FAX: 831-384-4312

sales@foxthermalinstruments.com

[www.foxthermalinstruments.com](http://www.foxthermalinstruments.com)

*Fox Thermal Instruments is ISO 9001 certified*