

racine™

Vortex Flow Meters

RNS Series **Insertion Steam Flow Meter**

- **Applications:**
 - Non-condensing steam
 - Process steam (saturated)
 - Energy and boiler monitoring
 - Building and facilities management
- Pipe sizes from 6" to 72" (152 to 1829 mm)
- 35:1 turndown ratio
- HART® Communication Protocol
- Optional compensation for mass flow measurement

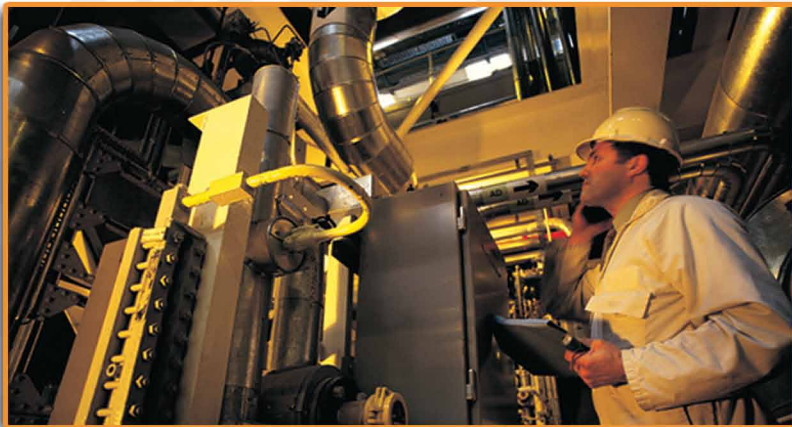

RNS Series Insertion Steam Flow Meter

The RNS Series meter is an insertion flow meter designed to offer high accuracy measurements of saturated steam flow in a variety of applications. The meters have no moving parts and are virtually maintenance-free once installed. The RNS Series is suitable for pipe sizes 6" (152 mm) and higher. All meters in this series are loop-powered devices with standard HART® communication for ease of field programming and system integration.

Operating Principle

An everyday example of a vortex shedding phenomenon is a flag waving in the breeze: the flag waves due to the vortices shed by wind moving across the flagpole. Within the flow meter, as flowing steam moves across the tiny strut or "bluff bar", vortices are also shed but on a smaller scale. The meter transmits an ultrasonic beam through the vortex pattern downstream of the strut. As vortices are shed the carrier wave of the ultrasonic signal modulates. The modulation in the carrier wave is measurable and proportional to the number of vortices shed. Digital processing enables the vortices to be counted, and this value is converted into a velocity. Software converts velocity into a volumetric flow rate, in units of measure selected by the operator.

Racine Vortex flow meters utilize the smallest strut in the industry, which allows for high levels of sensitivity; superior performance at low flow rates; high turndown ratios; and low pressure drop.

Through the use of the internal RTD and an external pressure sensor (not included), the flow meter software will compensate for changes in pressure and temperature, to achieve an accurate mass flow measurement.

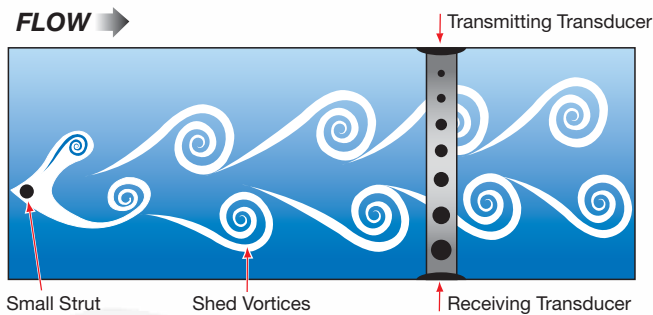

Flow Meter Selection

Racine vortex offers a sophisticated software program to aid in the flow meter selection process. The program accounts for system pressure and temperature, as well as media density, viscosity and specific gravity. Select from a complete list of Metric and English engineering units, using default or customized reference standards for pressure and temperature. This program may be downloaded at no charge from www.racinevortex.com.

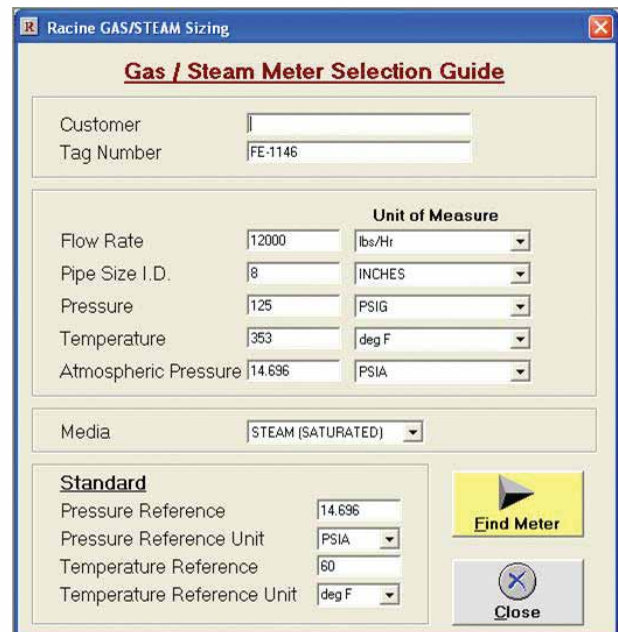

Specifications



Measured:	Saturated steam
Velocity Range:	5 to 175 FPS (1.5 to 53 MPS)
Operating Temperature:	-20 °F to +366 °F (-28 °C to +186 °C)
Ambient Temperature Limits:	-20 °F to +155 °F (-28 °C to +68 °C)
Operating Pressure:	-5 to 150 PSIG
Accuracy:	±1% of reading over the upper 90% of the flow range
Repeatability:	0.5% of reading
Input Power:	24 VDC
Signal Output:	2-wire, 4-20 mA loop
RTD:	Platinum, PT-100, high accuracy temperature measuring element
Construction:	316 Stainless steel, PEEK™, INCONEL® and Geothermal EPDM wetted parts, NEMA 7 transmitter enclosure standard
Communications:	HART® Protocol (via PC or HART Modem)
Certifications:	CE: EN61326-1:2002 Optional Intrinsically Safe conforms to: ATEX  II 2G Ex ib IIB T4 Zone 1 Group IIB T4 (Canada) and AEx ib IIB T4 (USA)
Options:	2 line, 8 digit rate/totalizer display Remote electronics

Flow Ranges*

Flow Range in LBS/HR in STEAM Flow Range in KG/HR in STEAM

Pipe Size	PRESSURE IN PSIG (BARg)										Pressure Drop (Inches H ₂ O) at 50% Max. Flow**
	25 (1.7)		50 (3.4)		75 (5.2)		100 (6.9)		140 (9.5)		
	MIN.	MAX.	MIN.	MAX.	MIN.	MAX.	MIN.	MAX.	MIN.	MAX.	
6" 152 mm	309	8355	489	16765	665	25190	839	31785	1210	42333	0.6
	140	3793	222	7612	302	11437	381	14431	549	19202	
8" 203 mm	549	14853	869	29805	1181	44782	1491	56507	2150	75258	0.4
	249	6744	395	13532	536	20332	677	25655	975	34137	
10" 254 mm	857	23208	1358	46571	1846	69973	2329	88292	3360	117591	Negligible
	389	10537	617	21144	838	31768	1057	40085	1524	53338	
12" 305 mm	1234	33419	1955	67062	2658	100760	3354	127140	4838	169331	Negligible
	560	15173	888	30447	1207	45746	1523	57723	2194	76807	
Temp °F (°C)	267 (130)		297 (147)		320 (160)		338 (170)		360 (182)		

*Consult RACINE Flow Meter Sizing Software for temperature and pressure conditions other than those listed here.

**Pressure drop data references air at 14.7 psig, and 60 °F (0 BARg and 16 °C).

Part Number Construction

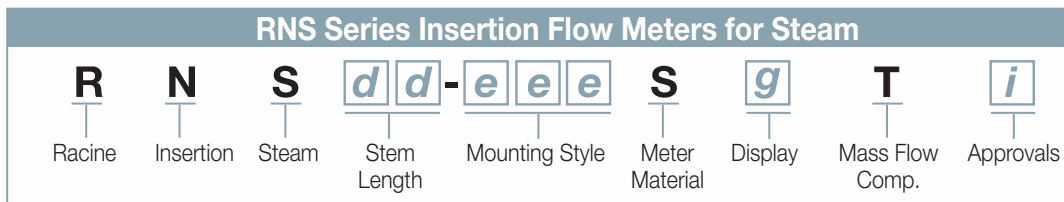

All meters include 4-20 mA output, HART Communication Protocol and NEMA 7 explosion-proof enclosure.

Part Number: **R N S** - **S** **T** **i**

dd Stem Length

- 12) 12" Stem
- 24) 24" Stem
- 36) 36" Stem
- 48) 48" Stem

**eee Mounting Style/
Cable Length**

- 150) 2" x 150# ANSI Flange¹
- 151) 2" x 150# ANSI Flange + 10' cable²
- 152) 2" x 150# ANSI Flange + 25' cable²
- 153) 2" x 150# ANSI Flange + 50' cable²
- 300) 2" x 300# ANSI Flange¹
- 301) 2" x 300# ANSI + 10' cable²
- 302) 2" x 300# ANSI Flange + 25' cable²
- 303) 2" x 300# Flange + 50' cable²
- NPT) 2" MNPT Fitting¹
- NP1) 2" MNPT Fitting + 10' cable²
- NP2) 2" MNPT Fitting + 25' cable²
- NP3) 2" MNPT Fitting + 50' cable²
- D50) DN 50 Flange^{1,3}
- D51) DN 50 Flange³ + 10' cable²
- D52) DN 50 Flange³ + 25' cable²
- D53) DN 50 Flange³ + 50' cable²

g Display

- N) No Display
- D) Integral 8-Digit Totalizer LCD⁴

f Meter Material

- S) 316 Stainless Steel (standard)

i Approvals

- S) CE (Standard)
- A) Intrinsically Safe

h Mass Flow Compensation

- T) Integral RTD, Temperature Compensation for Mass Flow Measurement⁵ (standard)

¹ Integral mount transmitter

² Remote mount transmitter (not available with Intrinsically Safe version)

³ Flange to DIN 2527 specifications

⁴ Not available with Intrinsically Safe version

⁵ Meter also accepts a 4-20 mA signal from an external pressure sensor (not included)

Dimensional Drawings Inches (mm)

Model	Inches (mm)			
	DIM A	DIM B	DIM C	DIM D
RNS12	12.0 (304.6)	14.50 (368.3)	25.1 (637.5)	15.83 (402.0)
RNS24	24.0 (609.1)	26.50 (673.1)	37.15 (943.6)	15.83 (402.0)
RNS36	36.0 (913.7)	38.50 (977.9)	49.15 (1248.4)	15.83 (402.0)
RNS48	48.0 (1218.3)	50.50 (1282.7)	61.15 (1553.2)	15.83 (402.0)

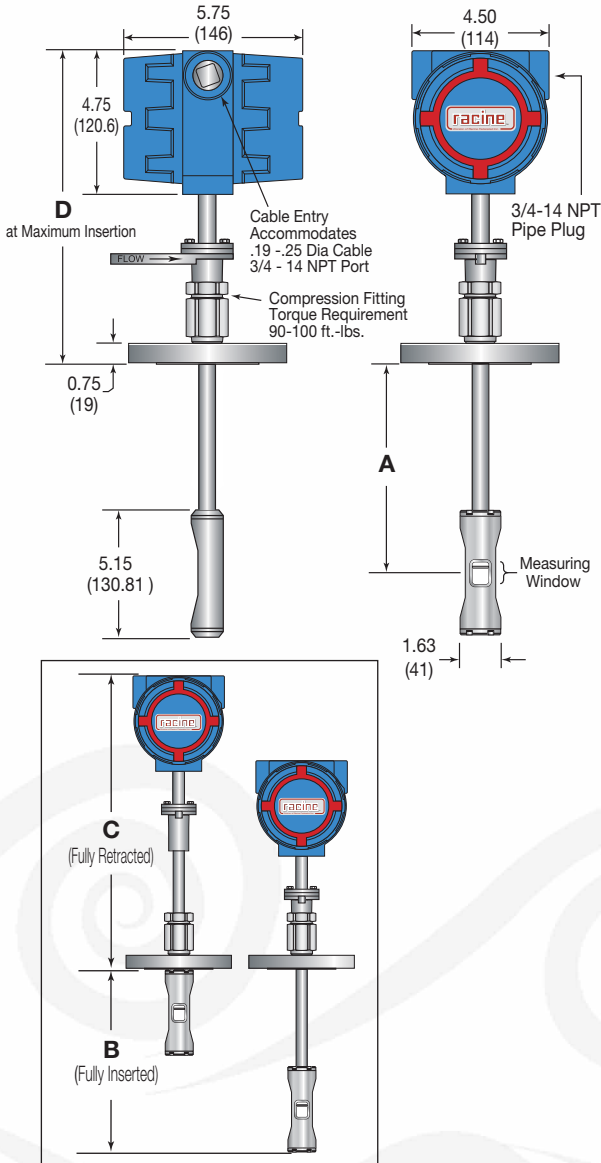

Note: 150# ANSI Flange dimensions shown.
For 300# ANSI Flange consult factory.

Stem Length Selection Procedure

Before purchasing a RNS insertion steam flow meter, it is necessary to calculate the stem length required for a particular piping system. In order to complete this calculation, some knowledge of the piping system must be known.

The variables required are:

- Internal pipe diameter (A)
- Pipe wall thickness (B)
- Length of the valve stack (C)

Using this information and referring to the picture to the right, a minimum stem length can be determined.

$$\text{Min. Stem Length Required} = A + B + C$$

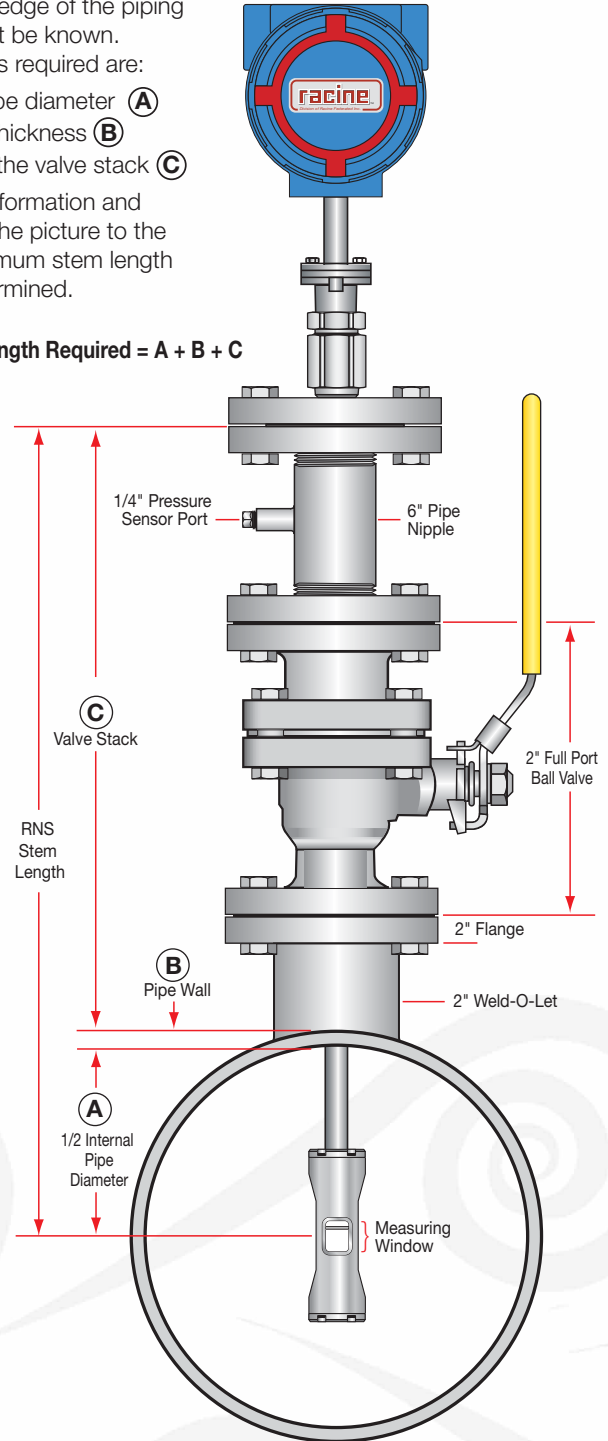

*Insertion hardware kits available with flanged or NPT connections.

racineTM
Division of Racine Federated Inc.

8635 Washington Avenue
Racine, WI 53406-3738 USA
vortex@racinefed.com

Racine is a trademark of Racine Federated Inc.
HART is a registered trademark of the HART Communication Foundation.
PEEK is a trademark of Victrex plc.
INCONEL is a registered trademark of Special Metals Corporation.
UL is a registered trademark of Underwriters Laboratories.
CSA is a registered trademark of Canadian Standards Association.
© 2010 Racine Federated Inc., all rights reserved. RNS-0001 09/10

RFI Racine Flow Meter Group **Blancett** **DYNASONICS** Flo-tech **HEDLAND** **PRESO** **racine**