

Experts in fire protection

MINIMAX

UniVario Industrial Fire Detectors Suitable for All Applications

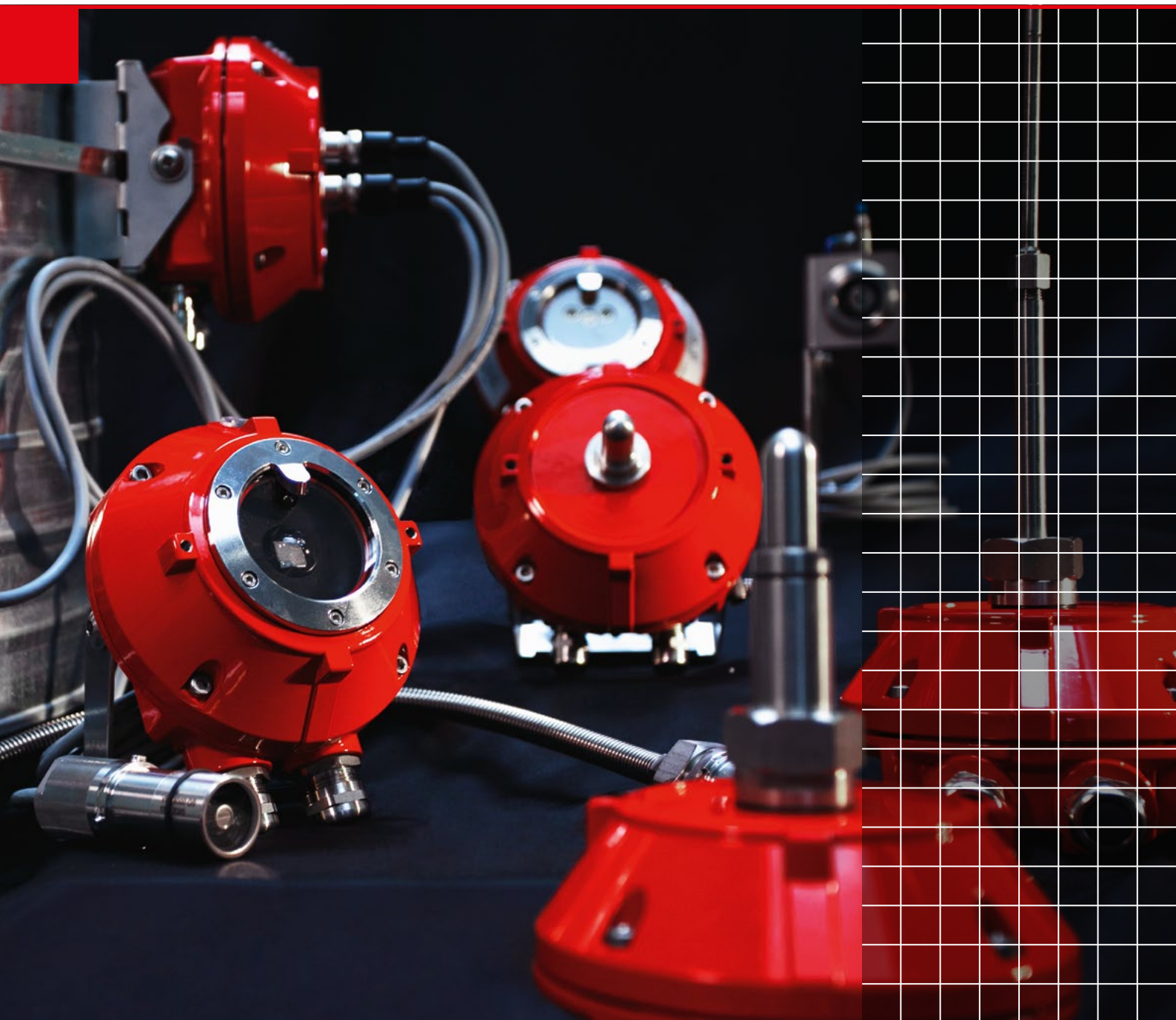

TECHNOLOGIES

UNIVARIO



The insurance for industrial manufacturing processes

UniVario industrial fire detectors are intelligent, platform-based, microprocessor-controlled fire detectors. Thanks to a modular concept and modern signal processing technologies, these detectors meet individual requirement profiles in a remarkably wide range of applications.

UniVario industrial fire detectors operate indoors and outdoors, in the immediate vicinity of the equipment to be protected as well as from greater distances. They can be used in clean room areas as well as under harsh process conditions, and in explosion hazard areas, thus offering solutions for all requirements.

Modular design – unlimited flexibility

UniVario industrial fire detectors combine fast-response sensors with intelligent evaluation algorithms – for rapid fire detection without false alarms. The ability to intelligently suppress false alarm sources and adjust the high response temperatures to the exact degree means that UniVario industrial fire detectors can be used for a wide range of applications – even in explosion hazard areas.

The application-specific configuration of the signal processing and the modularity allow for easy adaptation to changing operating conditions.

The exceptional operational reliability of UniVario industrial fire detectors is ensured by microcontroller function monitoring, high enclosure tightness (IP66, IP67), as well as impact and vibration resistance. Silicone-free versions as well as specially protected designs for paint shops or pickling with optional air flushing pass even the toughest requirements.

The multitude of worldwide approvals and recognitions confirms their quality and application possibilities. UniVario industrial fire detectors are FM-approved and tested, and certified by VdS Schadenverhütung, depending on the detector variant. Additional approvals are available from other international certification bodies, such as CCC, Russian Conformity, MOE, CPD, CSFM, ATEX, IECEx and NEC.

In order to ensure the most effective protection for each application, UniVario detectors are used in different designs and sensitivities, i.e. adapted to the specific equipment. Versions with detached sensor systems are available for special applications in object protection.



The **WMX5000** is designed to detect open fires with rapid heat development, which can occur, for example, with easily combustible plastics or flammable liquids and gases. The heat parameters can be evaluated differentially for early fire detection in addition to the maximum temperature measurement, even in the event of a rapid temperature increase.

The special **WMX5000 Single Hole** mounting version facilitates monitoring in dryer or ventilation ducts, for example. UniVario WMX5000 – the heat detector with stainless steel heat sensor.

UniVario WMX5000 FS – a high-temperature heat detector with detached stainless steel heat sensor. The WMX5000 FS high-temperature heat detector operates especially in areas with high application temperatures up to 850 °C. Its detached heat sensor enables simple, extremely flexible mounting. Adjustable alarm temperatures and different detached heat sensor versions allow for a wide range of applications.



UniVario FMX5000 IR – a reliable flame detector with three sensors and triple optical test. The three-channel infrared flame detector detects open flames particularly quickly and reliably. A special sensor combination and intelligent evaluation hide industry-typical false alarm sources such as hot machines surfaces or welding work. At the same time, the detector reliably detects even very small flames from an emerging fire. The integrated optical test, which checks all three sensors as well as the detector optical window, makes the UniVario FMX5000 IR particularly reliable in operation.

The **FMX5000 UV** flame detector reacts to optical radiation in the ultraviolet range. It monitors areas where the rapid development of open flames is likely to occur if a fire breaks out. The perfect combination of early detection, high sensitivity, reliability, and high false alarm resistance makes the UniVario fire detector indispensable for anticipating the rapid development of fires.

The order of the descriptions corresponds to the illustration.

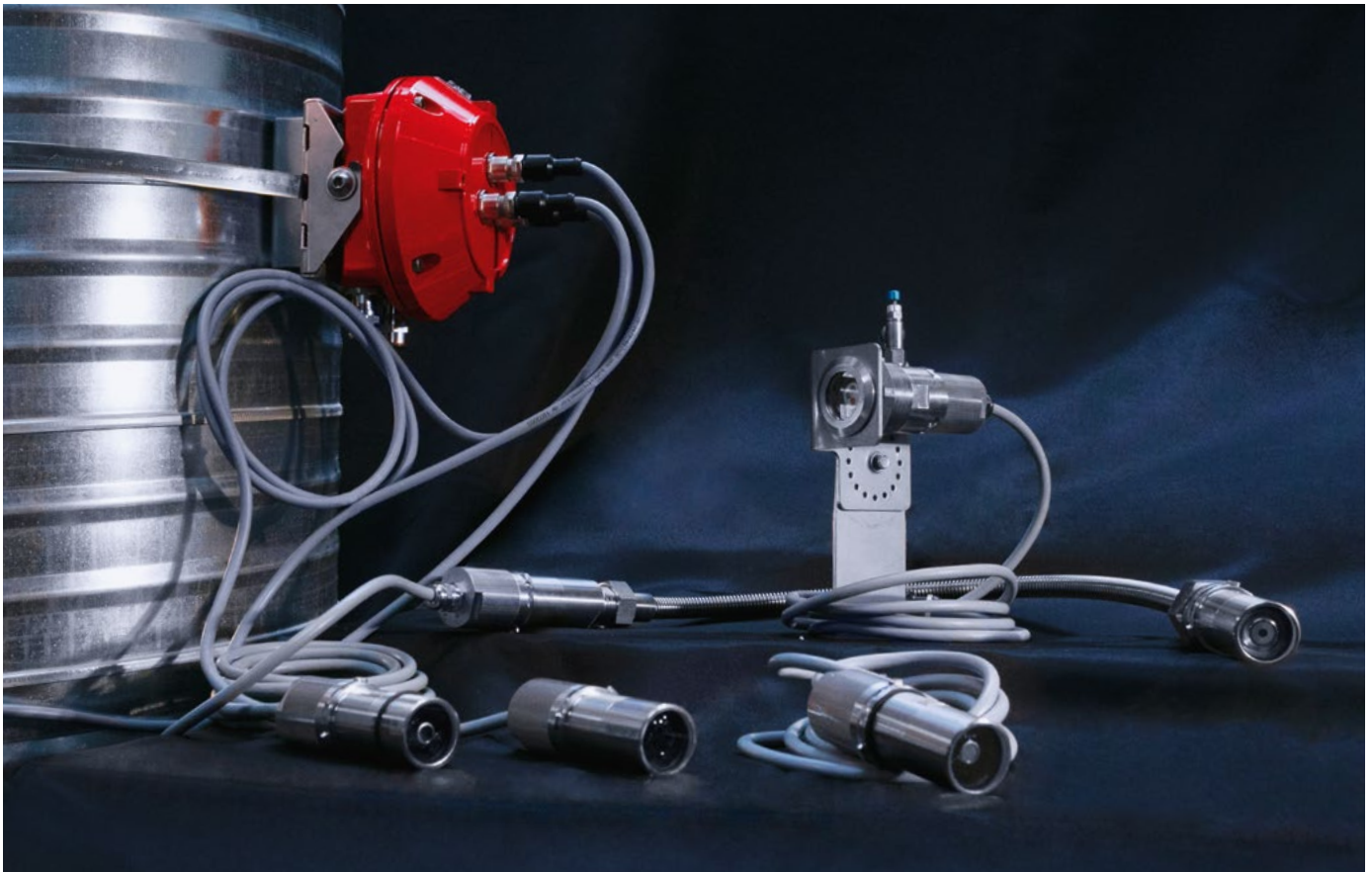

UniVario YMX5000 – the modular UniVario YMX5000 detection system consists of an control unit with three ports and detached sensor units for spark and rapid flame detection. The system meets individual requirements in a broad spectrum of applications. It is ideally suited for confined installation conditions in harsh, industrial environments. For the application area of spark detection in particular, the UniVario YMX5000 system can also be used in extreme temperature ranges. The corresponding FUX sensor unit can be used at temperatures from -40 to 105 °C, even without fiber optics.

The electronics of the sensor units are located in a stainless steel housing. It is connected to the control unit via a cable plug. **YMX5000 FUX** type sensor units are used wherever there is an increased risk of fire from sparks. **YMX5000 FMX** type sensor units are rapid three-channel IR flame detectors capable of reliably detecting open flames.

The sensor units cyclically check the optics for possible contamination or damage – a unique selling point that increases operational reliability and is second to none.



The **"Ex" sensor units** are suitable for use in Ex zones 1, 2, 20, 21, and 22. These sensor units are operated on the **YMX5000 3GD** control unit, which can be used in Ex zones 2 and 22.



Suitable product for explosion hazard areas as well

Use in explosion hazard areas

UniVario industrial fire detectors are available in special versions for use in gas and dust explosion hazard areas in industrial environments.

- The standard versions of the UniVario industrial fire detectors can be used for applications outside hazard areas.
- The 3GD series detectors can be used for Zone 2 (gas) and Zone 22 (dust) applications.

All detector versions can be used as ring bus detectors. An additional safety barrier is used with the UniVario Ex series detectors.

- The Ex series of UniVario industrial fire detectors are suitable for Zones 1 (gas), 20, and 21 (dust)

Detector version	Standard	3GD (Zone 2/22)	Ex (Zone 1/2/20/21/22)
Ultraviolet flame detectors			
Three-channel infrared flame detectors			
Standard heat detectors			
High-temperature FS heat detectors			
Spark detectors			
Rapid flame detectors			

Always keep an eye on things

The UniVario YMX5000 control unit monitors essential functions automatically and offers additional safety through its status display and history memory.

The electronics of the sensor units are located in a stainless steel housing. It is connected to the control unit via a cable plug.

Various configuration options increase the system flexibility.

The control unit is mounted using a swivel or a wall or pipe mounting bracket. Installation of the sensor units is simple and safe thanks to a single-hole mounting with bayonet locking.

If necessary, an air flushing can be integrated, leaving the sensor's large viewing angle of 120° unaffected. Each sensor unit is equipped with interchangeable optics that can be replaced quickly and easily. This makes maintenance particularly easy.

Versions with fiber optics for monitoring up to 300 °C, e.g. in dryer areas, as well as versions for areas with daylight, e.g. in drop shafts, are available.

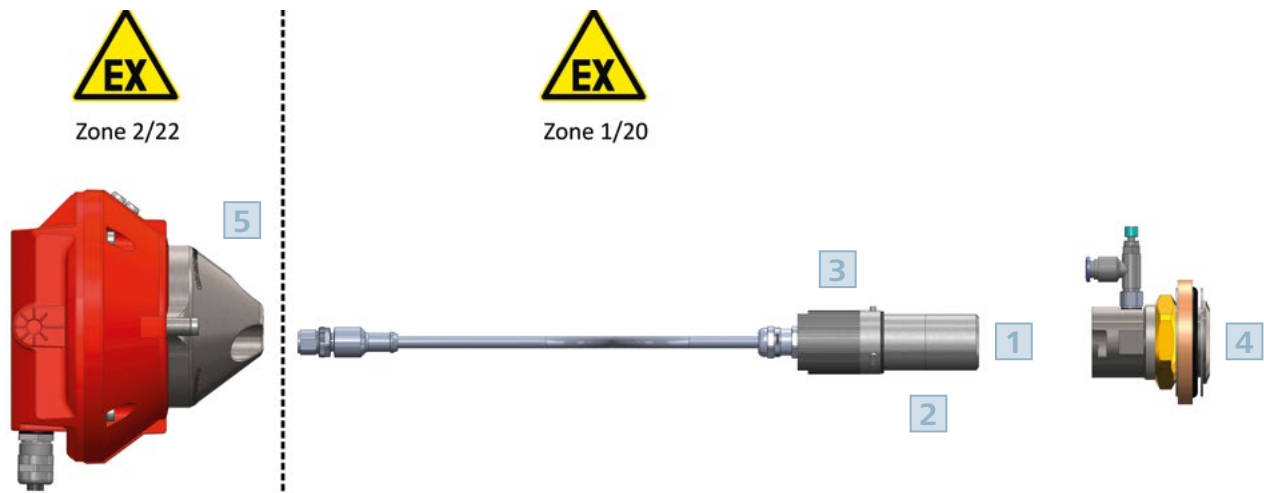

1 Optics monitoring and 120° viewing angle

2 Interchangeable optics

3 Operating temperatures from -40 to 105 °C possible

4 Air flushing with 120° viewing angle

5 Modularity different sensor units

Suited in any case

UniVario – the communicative detector in the loop

UniVario industrial fire detectors can be expanded to full-fledged ring bus detectors using communication modules. This means that they can be integrated into the fire alarm system as stand-alone detectors with a protocol, simply by inserting

a module. Events can be precisely assigned to a detector and appropriate measures initiated by the fire detection and suppression control panel. UniVario detectors are the first industrial fire detectors to make this possible in explosion hazard areas.

Communication modules

The KMX5000 AP and KMX5000 AP Ex modules enable UniVario industrial fire detectors to be operated as complete ring bus devices on fire alarm control panels with the Loop AP protocol – without the need for separate loop couplers.

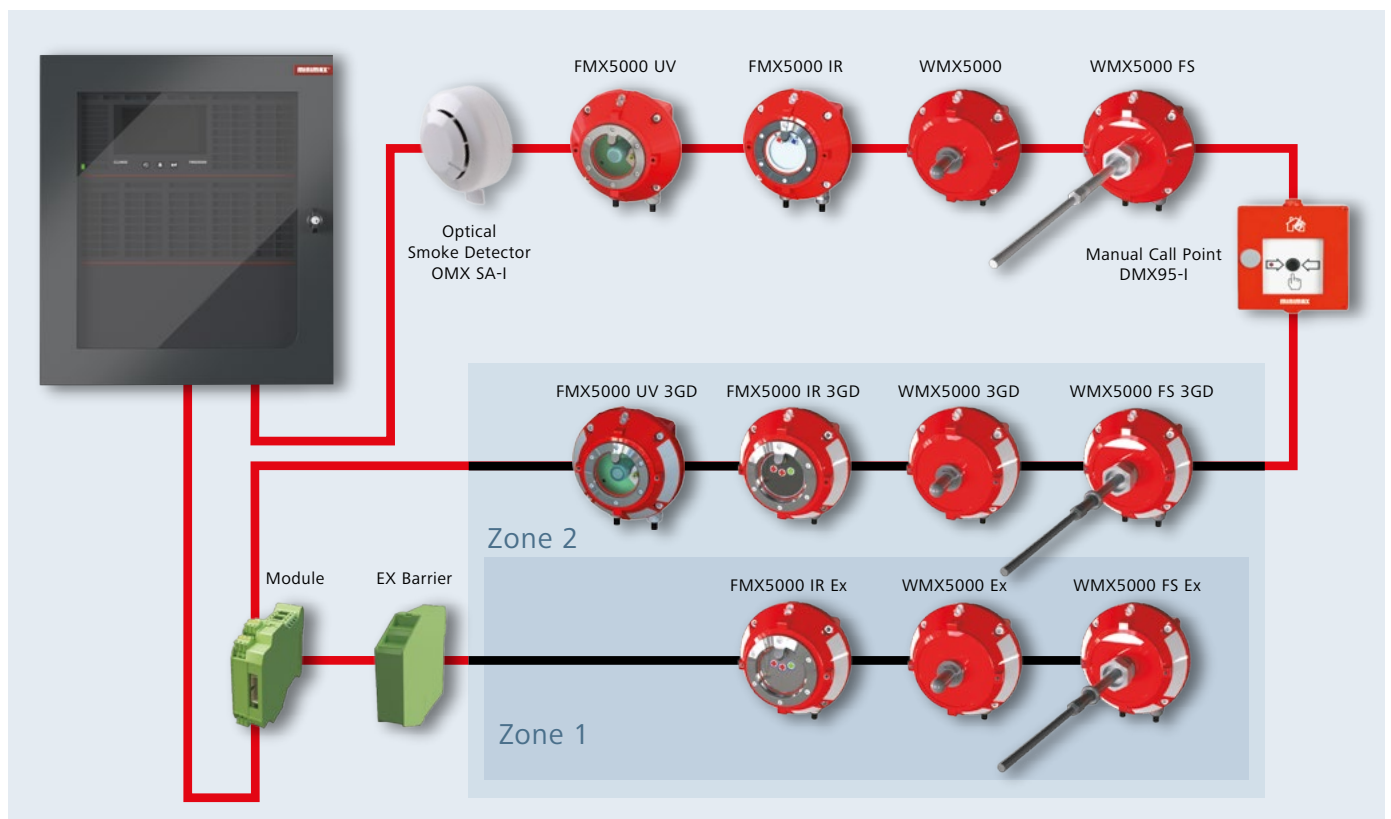

Diverse and almost limitless

Application examples	FMX5000 IR	FMX5000 UV	WMX5000	WMX5000 FS	YMX5000 spark detectors	YMX5000 flame detectors
Air exhaust/flue gas ducts				●	●	
Fuel/chemical storage	●					●
Chemical production	●			●		●
Chip/semiconductor manufacturing (silanes)		●		●		
Printing/printing machines	●	●	●			●
Aircraft/helicopter hangars	●	●				
Heating/coal power stations	●					●
Wood fiberboard presses (heat tunnel)				●	●	
Wood processing industry	●				●	●
Fuel tanks		●	●			
Paint shops			●			●
Engine test stands	●			●		●
Waste processing plants	●		●			●
Pumping stations	●					●
Tank fields	●	●				●
Transformers			●			
Dryer				●	●	
Compressor stations (natural gas)	●	●				●
Machine tools			●	●		●
Machine tools (Mg/Al/Ti dry machining)		●				

Advantages at a glance

The UniVario industrial fire detectors are equipped with robust housing and mounting technology for the harshest operating conditions. They function indoors and outdoors,

in the immediate vicinity of the equipment to be protected or from greater distances, in clean room areas as well as extremely dirty process conditions.

- Fast fire detection with high false alarm resistance
- High degree of operational safety
- Wide range of applications, including for high temperatures and silicone-free areas
- Easier adaptation to changing operating conditions
- Savings potential and sustainability due to low energy requirements
- Flexible connection technology, easy installation
- Worldwide approvals and recognitions

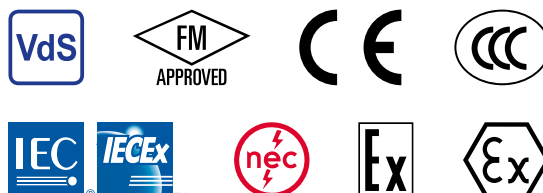

Photos

Title: Minimax GmbH, Bad Oldesloe
Page 2: Oliver Güth, Cologne
Page 5: Minimax GmbH, Bad Oldesloe
Page 6: Minimax GmbH, Bad Oldesloe
Page 7: Michael Haydn, Steinburg

Minimax GmbH
Industriestraße 10/12
23840 Bad Oldesloe
+49 4531 803-0
www.minimax.com