

THERMATEL® TD1/TD2

Thermal dispersion switch

DESCRIPTION

Thermatel® TD1/TD2 switches can easily be adjusted to detect flow (gases and liquids), level or liquid-liquid interface. The TD1 is a 24 V DC line powered unit with integral electronics and a built-in DPDT relay. The TD2 is either V DC or V AC line powered, has integral or remote electronics and offers additionally LED indication, time delay and mA output for diagnostics and trending.

TD1/TD2 switches provide continuous diagnostics with fault indication, temperature compensation, narrow hysteresis and fast response time.

FEATURES

- Easy field calibration – pre-calibration from factory at request.
- Variable flow or Flow/No flow detection of gases and liquids.
- Excellent low flow sensitivity.
- Automatic temperature compensation for repeatable alarm under varying process temperatures.
- Continuous diagnostics detect sensor fault.
- Continuous monitoring of flow rate versus setpoint via LED (TD2).
- mA output provides repeatable indication of flow rate and fault detection (TD2).
- Flow can be measured over test points (TD2).
- Optional retractable fitting for dismantling under process conditions.
- Process conditions up to +450 °C (+850 °F) and 414 bar (6000 psi).
- Integral or remote electronics up to 150 m (500 ft).
- Unique spherical tip design option ideal for liquids or high viscosity applications.
- Suited for SIL1 and SIL2 loops (full FMEDA report available).



APPLICATIONS

MEDIA: all types of gases and liquids.

VESSELS: pipe sizes down to 1/4". Max sensor length up to 3,3 m. Can be installed at any angle vertically/horizontally – flanged, threaded or with compression fitting with or without hot or cold tap – ask for bulletin 41-103.

CONDITIONS: Can be used on conductive and non conductive media, very light density to heavy viscous media (up to 10.000 cP). Can be set to ignore foam, aeration, turbulence, and cavitation.

For FLOW/LEVEL/INTERFACE applications



AGENCY APPROVALS^①

Agency	Approval
ATEX	For TD1 & TD2: II 1/2 G Ex db+ib, db [ib] IIC T5..T4 Ga/Gb, flameproof enclosure with intrinsically safe probe circuitry (not valid for hermetically sealed relay option)
	For TD2 only: II 2 G Ex db IIC T5..T4 Gb, flameproof enclosure (zone 1)
IEC	For TD1 & TD2: Ex db + ib, db [ib] IIC T5/T4 Gb/Ga
	For TD2 only: Ex db IIC T5/T4 Gb
FM/CSA ^②	
	Russian Authorisation Standards ^②
	Other approvals are available, consult factory for more details

^① Refer to bulletin BE 54-105 for ATEX intrinsically safe units.

^② Consult factory for proper model numbers and classifications.

TECHNOLOGY

The unit utilises the proven thermal dispersion technology. The sensor consists of two RTD (Resistance Temperature Detector) elements. One is the reference and the second is heated to a temperature above the process temperature. The electronics detect the temperature difference between the two elements. The temperature difference is greatest in air, then decreases when cooling occurs due to a change in media. An increase in the flow rate further decreases the temperature difference.

The set point is adjusted for the switch to alarm at the desired temperature difference. Once the set point is reached, the relay will change state.

Flow

No Flow/Low Flow
In the absence of flow/low flow, the self-heated sensor creates a temperature differential between the two sensors.

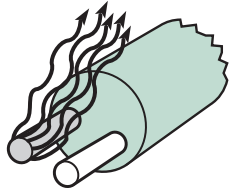
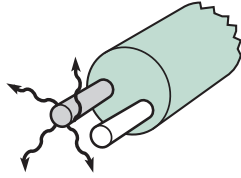

Flow
As media flow increases across the sensing assembly, heat is dissipated and temperature differential decreases .

Level

Low Level
In the absence of media, the self-heated sensor tip creates a temperature differential between the two sensors.

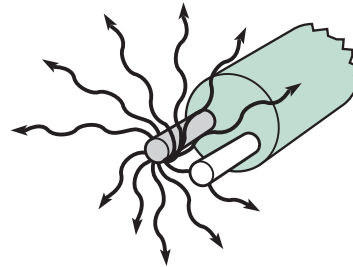
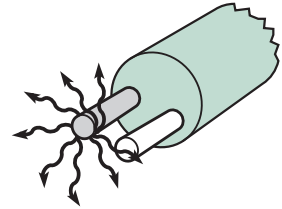

High Level
As media contacts the sensing assembly, heat is absorbed by the fluid, decreasing the temperature differential.

ADVANCED FEATURES

TEMPERATURE COMPENSATION (TD1 & TD2)

The alarm point of thermal dispersion switches has previously been affected by changing temperatures. With the TD1/TD2, the effect of changing process temperature has been greatly reduced.

No temperature compensation

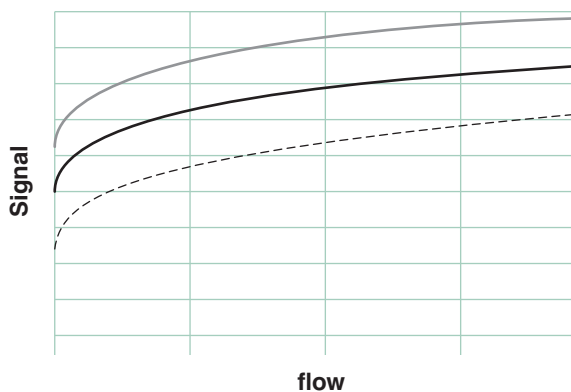

With temperature compensation

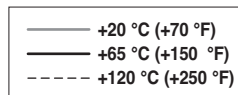
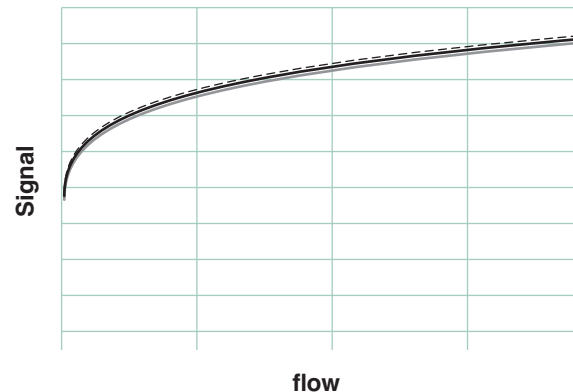

FACTORY CALIBRATION (TD1 & TD2)

TD1/TD2 can be delivered pre-calibrated at a fixed setpoint.

TD2 can be delivered with a complete calibration curve, allowing the customer to field adjust the setpoint by using a voltmeter at the test points.^①

^① Calibration curve to points not available with zone 0, digit 9=C

ADVANCED FEATURES (CONT.)

FAULT DETECTION (TD1 & TD2)

The TD1/TD2 is equipped with advanced diagnostics which continuously monitor the signal from the sensor and indicate if the signal has gone out of range. In the event of a fault, the alarm relay will de-energize and the red LED will blink.

In the TD2 the mA output will change to 3,6 mA (Low Level Fail-safe) or 22 mA (High Level Fail-safe) to indicate a fault.

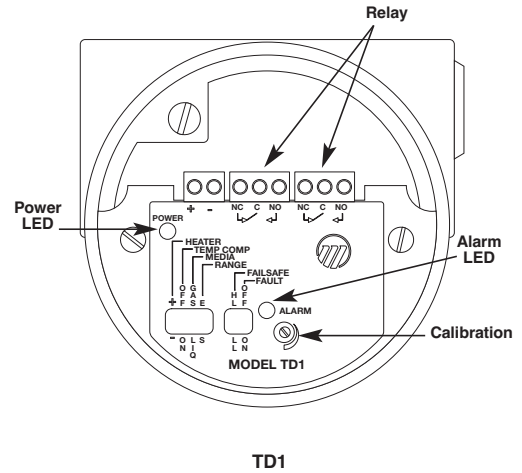

mA OUTPUT (TD2 only)

- for trending: the calibrated setpoint corresponds with a specific mA value but although not linear, it provides important process information. With increasing flow or immersed sensor, the mA signal increases.
- for diagnostics: either 3,6 mA (Low Level Fail-safe) or 22 mA (High Level Fail-safe) output, indicates for an instrument failure (sensor).

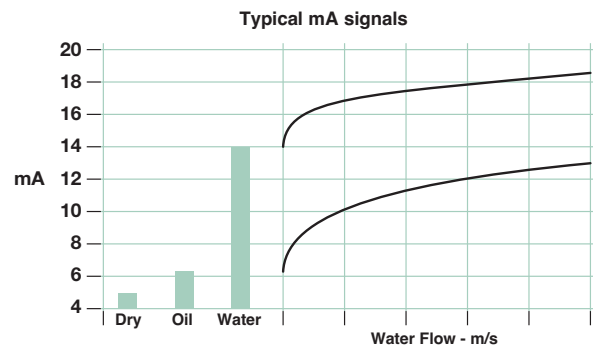

TEST POINTS (TD2 only)

Allow the user to periodically check the setpoint and verify for set point drift. The setpoints read voltage units.

LED INDICATION (TD2 only)

The LED's show progressively actual flow/level versus the calibrated setpoint.

REMOTE ELECTRONICS (TD2 only)

The sensor can be mounted away for 150 m (500 ft). The order code for the remote electronics includes the sensor housing.

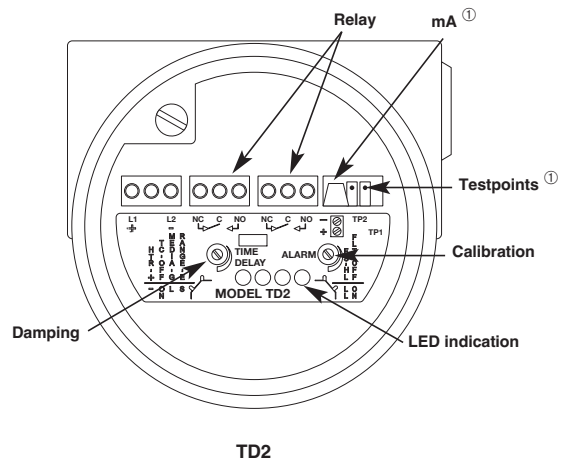

① Not for all models - see electronics part number on page 7

APPLICATIONS

FLOW

Thermatel® TD1/TD2 switches may be installed in a variety of flow applications as shown in the illustration below. Flow/No Flow can be detected in an input line to a primary tank, or in an output line. They may be installed for overflow detection in a pipe connected to an overflow tank or installed in a drain line for Wet/Dry indication. In addition, due to the capability to detect liquids or gases, the Thermatel® flow switch may be installed in a gas vent to detect off-gas from the primary tank.

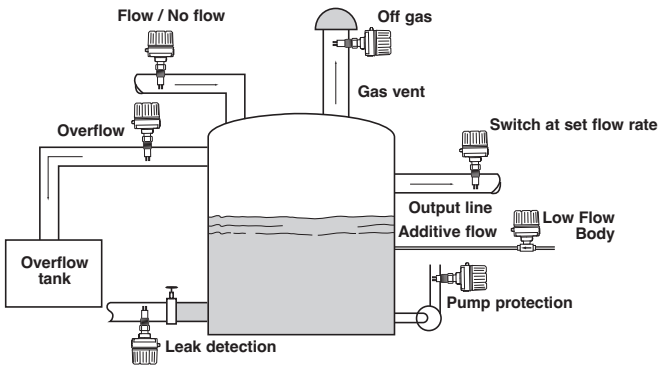

- Liquid or Gas flow detection
- Maintain a minimum flow rate
 - Pump protection
 - Cooling air/water
 - Lubrication systems
 - Chemical feed pumps
- Detect presence of flow
 - Relief valves
 - Flare lines

LEVEL

Thermatel® TD1/TD2 switches can be installed in a variety of level applications as shown in the illustration below. High or low level alarm applications can be installed in either vertical or horizontal mountings.

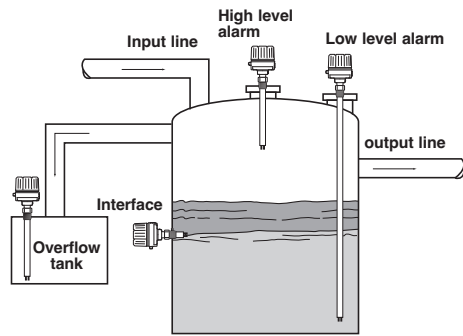

- High level
- Low level
- Interface between different media
 - Oil/water
 - Liquid/foam
- Suitable for any liquid level detection including:
 - High viscosity
 - High solids content
 - Aeration
 - Foam
- Insensitive to dielectric, specific gravity, viscosity

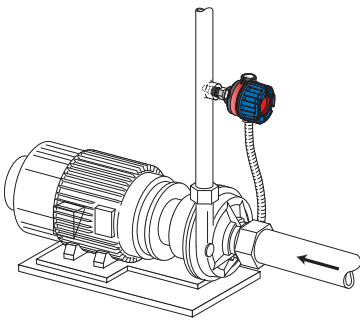

Pump Protection

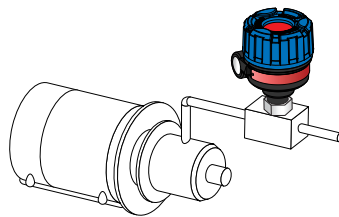

Chemical Feed Pump

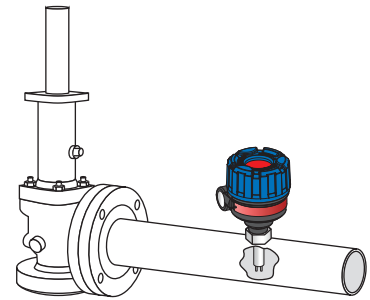

Relief Valve Monitoring

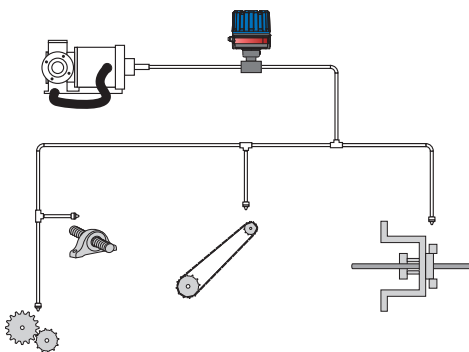

Lubrication Systems

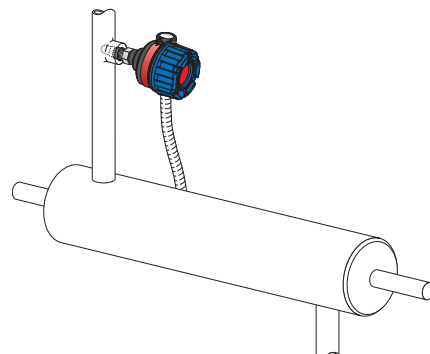

Cooling Water / Cooling Air

SENSOR DESIGNS

Thermatel offers two sensor tip designs: the twin tip and the unique spherical tip. Both designs have similar operating ranges. Both detect flow or level at approximately the same rate. However, the spherical tip responds faster to a loss of flow or a dry condition.

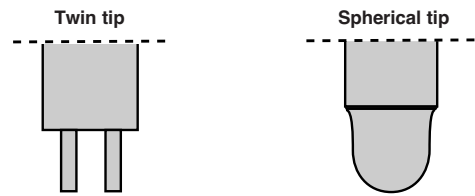

SPHERICAL TIP

The sensing elements are bonded directly to the wall of the tip, providing protection of the sensors.

The spherical tip is recommended for all types of applications: general purpose use, liquid flow applications, full vacuum, high viscosity and applications where buildup can occur. The spherical tip is suitable for process pressures up to 41,4 bar (600 psi) and can handle process temperatures up to +200 °C (+400 °F).

TWIN TIP

The sensing elements are mounted at the end of each tip.

The twin tip is preferred for air flow applications and is available in corrosion resistant materials including Hastelloy C and Monel. The twin tip is suitable for process pressures up to 207 bar (3000 psi) and can handle process temperatures up to +200 °C (+400 °F).

HIGH TEMPERATURE/HIGH PRESSURE (TMH)

This twin tip sensor is suitable for process pressures up to 414 bar (6000 psi) and can handle process temperatures up to +450 °C (+850 °F).

MINI SENSOR (TMM)

This twin tip sensor is suitable for installing in smaller pipe sizes. Available with 1/2", 3/4" and 1" NPT connections. The twin tip design provides minimal blockage of the pipe.

LOW FLOW BODY (TML)

This version is used for even lower flow rates with 1/4" and 1/2" connections.

Typical air flow

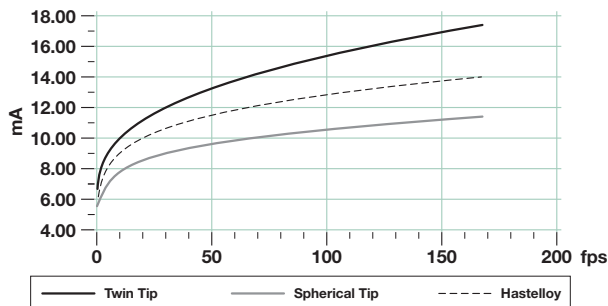

Typical water flow

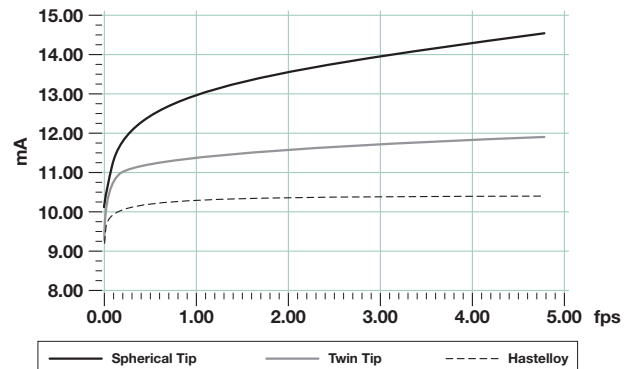

Model	Sensor design	Recommended for
TMA	Spherical tip	Best sensitivity for liquid flows / suitable for gas flow – resists heavy coating
TMB	Spherical tip	Same as TMA but can be used with integral electronics up to +200 °C (+400 °F)
TMC	Twin tip	Best sensitivity for air/gas flows – resists light coating
TMD	Twin tip	Same as TMC but can be used with integral electronics up to +200 °C (+400 °F)
TMH	Twin tip	High temperature and/or high pressure conditions – resists light coating
TMM	Mini twin tip	Installation in small pipe sizes – resists light coating
TML	Low flow body	Detection/control of extreme low flows – resists light coating

QUICK RESPONSE CELL (QRC)

Several models are available for extra quick shipment, within max. 15 days after factory receipt of purchase order, through the Quick Response Cell (QRC).

Models covered by QRC service are conveniently green coded in the selection data charts.

To take advantage of QRC, simply match the green model number codes (standard dimensions apply).

QRC delivery is limited to a maximum of 10 units per order. Contact your local representative for lead times on larger volume orders, as well as other products and options.

SELECTION DATA

A complete measuring system consists of:

1. THERMATEL® electronics
2. Connecting cable (only applicable for remote mount TD2 units)
3. THERMATEL® sensor
4. Optional: Order code for thread-on mounting flanges
5. Optional: Retractable probe assembly, consult factory for details
6. Optional: Factory calibration, consult factory



TD1



TD2

1. Order code for Thermatel® TD1 electronics

1 - 8 | BASIC MODEL NUMBER

T D 1 - 2 D 0 0 - 0	Integral mount electronics for 24 V DC power supply and with 1 DPDT 8 A DPDT output relay
---------------------	---

9 | APPROVAL

3	Weatherproof
C	ATEX/IEC flameproof enclosure with intrinsically safe probe circuitry

10 | HOUSING / CABLE ENTRY

0	IP66, Cast aluminium, 3/4" NPT cable entry (2 entries - 1 plugged)
1	IP66, Cast aluminium, M20 x 1,5 cable entry (2 entries - 1 plugged)

T	D	1	-	2	D	0	0	-	0		
1	2	3		4	5	6	7		8	9	10

complete order code for Thermatel® TD1 electronics

→ X = product with a specific customer requirement

SELECTION DATA (CONT.)

1. Order code for Thermatel® TD2 electronics

1 2 3 | BASIC MODEL NUMBER

T	D	2	Electronics with continuous LED indication and mA output
---	---	---	--

4 | POWER SUPPLY

7	240 V AC (100-264 V AC)
8	24 V DC (± 20 %)

5 6 | OUTPUT

D 0	8 A DPDT relay
H 0	1 A Hermetically sealed DPDT relay (Relay contact material: gold plated)

7 | ACCESSORIES

0	Blind housing cover
1	Housing cover with glass window (for aluminium housings only)

8 | MOUNTING CONFIGURATION

0	Integral electronics
1	Remote electronics

9 | APPROVAL[Ⓢ]

3	Weatherproof
C	Zone 0 – for level applications ATEX/IEC flameproof enclosure with intrinsically safe probe circuitry - no mA output / no test points available - only available with 8 A DPDT relay option
G	Zone 1 – for level and flow applications ATEX/IEC flameproof enclosure

[Ⓢ] Consult factory for zone 0 applications in combination with hermetically sealed relay.

10 | HOUSING / CABLE ENTRY

0	IP66, Cast aluminium, 3/4" NPT cable entry (2 entries - 1 plugged)
1	IP66, Cast aluminium, M20 x 1,5 cable entry (2 entries - 1 plugged)
2	IP66, Cast stainless steel, 3/4" NPT cable entry (2 entries - 1 plugged)
3	IP66, Cast stainless steel, M20 x 1,5 cable entry (2 entries - 1 plugged)

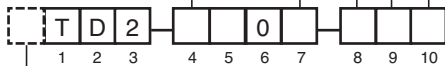

complete order code for Thermatel® TD2 electronics

X = product with a specific customer requirement

2. Order code for connecting cable used with weatherproof remote mount TD2 electronics (6-wire cable/shielded). Consult factory for cable suitable for flameproof enclosure.

8 - 10 | CONNECTING CABLE LENGTH

0	0	3	-	1	5	0	From 3 m (10 ft) min. to 150 m (500 ft) max. Specify in increments of 1 m (3.28 ft)
---	---	---	---	---	---	---	---

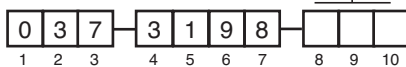

complete order code for connecting cable

CONNECTIONS

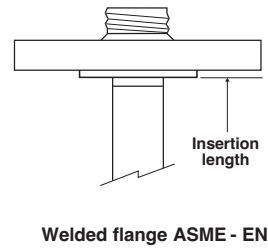
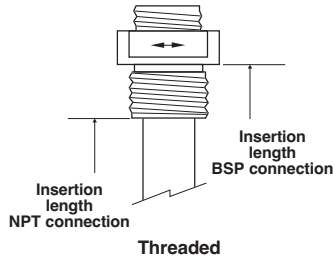

DIMENSIONS IN mm (inches) – TMA/TMB/TMC/TMD

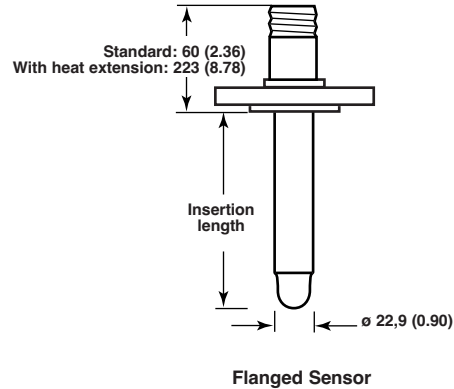
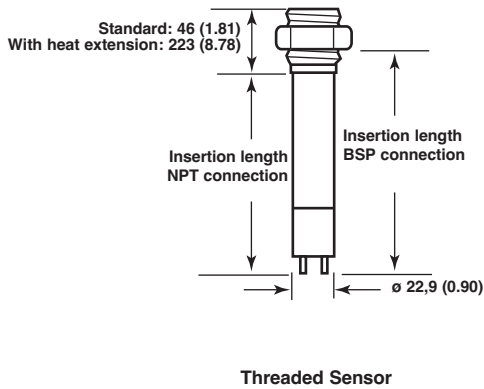

PRESSURE/TEMPERATURE RATING – TMA/TMB/TMC/TMD

Sensor	Material code	Insertion length	Maximum process pressure		
			@ +40 °C (+100 °F)	@ +120 °C (+250 °F)	@ +200 °C (+400 °F)
TMA, TMB	A	All	41,4 bar (600 psi)	33,8 bar (490 psi)	28,6 bar (415 psi)
	K, M, N	All	27,6 bar (400 psi)	22,4 bar (325 psi)	19,0 bar (275 psi)
TMC, TMD	A, D, K, M, N	= minimum length	207 bar (3000 psi)	170 bar (2460 psi)	148 bar (2140 psi)
		> minimum length	128 bar (1850 psi)	105 bar (1517 psi)	91,0 bar (1320 psi)
TMC, TMD	B, F	= minimum length	207 bar (3000 psi)	181 bar (2627 psi)	161 bar (2340 psi)
		> minimum length	103 bar (1500 psi)	90,6 bar (1313 psi)	80,7 bar (1170 psi)
TMC, TMD	C, G	= minimum length	172 bar (2500 psi)	147 bar (2125 psi)	137 bar (1980 psi)
		> minimum length	82,8 bar (1200 psi)	70,3 bar (1020 psi)	65,5 bar (950 psi)

TMA/TMB sensors

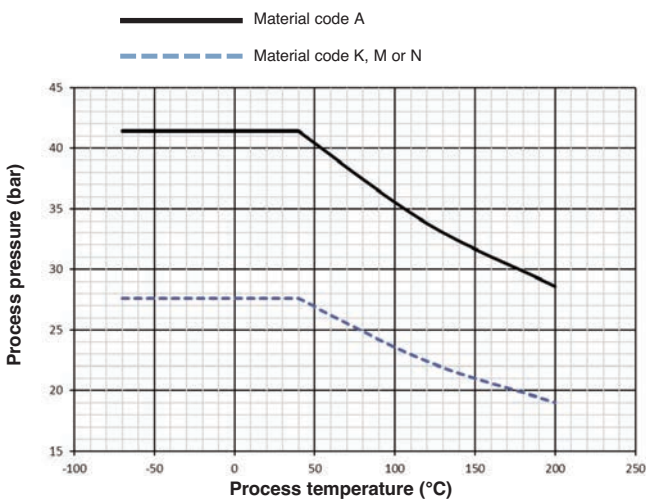

TMC/TMD sensors with material code A, D, K, M or N

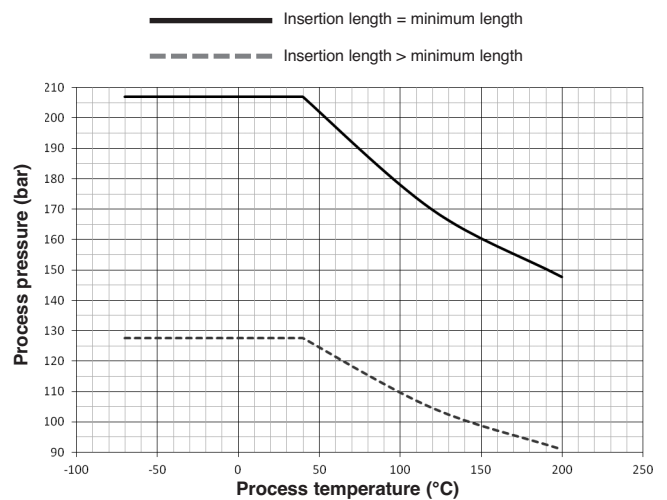

SELECTION DATA (CONT.)

3. Order code for Thermatel® TD1/TD2 – STANDARD SENSOR

1 2 3 | BASIC MODEL NUMBER

T M A	Spherical tip - standard	max +120 °C (+250 °F) ^①
T M B	Spherical tip - with heat extension	max +200 °C (+400 °F)
T M C	Twin tip - standard	max +120 °C (+250 °F) ^①
T M D	Twin tip - with heat extension	max +200 °C (+400 °F)

^① TMA/TMC sensors can handle process temperatures up to +200 °C (+400 °F) with remote electronics.

4 | MATERIAL OF CONSTRUCTION FOR SENSOR AND PROCESS CONNECTION

A	316/316L (1.4401/1.4404) stainless steel ^①	
B	Hastelloy® C (2.4819)	– TMC/TMD only
C	Monel® (2.4360)	– TMC/TMD only
D	316/316L (1.4401/1.4404) stainless steel	– TMC/TMD only
F	Hastelloy® C (2.4819), NACE	
G	Monel® (2.4360), NACE	
K	316/316L (1.4401/1.4404) stainless steel, ASME B31.3	
M	316/316L (1.4401/1.4404) stainless steel, ASME B31.3 and NACE	
N	316/316L (1.4401/1.4404) stainless steel, NACE	

^① Not suitable for zone 0 applications in combination with hermetically sealed relay; use in this case material code D.

5 6 7 | PROCESS CONNECTION – SIZE/TYPE

Threaded

1	1	0	3/4" NPT
2	1	0	1" NPT
2	2	0	1" BSP (G 1")

No threads – only for use with compression fitting

0	0	0	Compression fitting (customer-supplied)
---	---	---	---

ASME flanges

2	3	0	1"	150 lbs ASME RF
2	4	0	1"	300 lbs ASME RF
2	5	0	1"	600 lbs ASME RF
3	3	0	1 1/2"	150 lbs ASME RF
3	4	0	1 1/2"	300 lbs ASME RF

3	5	0	1 1/2"	600 lbs ASME RF
4	3	0	2"	150 lbs ASME RF
4	4	0	2"	300 lbs ASME RF
4	5	0	2"	600 lbs ASME RF

EN flanges

B	B	0	DN 25	PN 16/25/40	EN 1092-1	Type A
B	C	0	DN 25	PN 63/100	EN 1092-1	Type B2
C	B	0	DN 40	PN 16/25/40	EN 1092-1	Type A
C	C	0	DN 40	PN 63/100	EN 1092-1	Type B2
D	A	0	DN 50	PN 16	EN 1092-1	Type A
D	B	0	DN 50	PN 25/40	EN 1092-1	Type A
D	D	0	DN 50	PN 63	EN 1092-1	Type B2
D	E	0	DN 50	PN 100	EN 1092-1	Type B2

8 9 10 | INSERTION LENGTH – MINIMUM

		Sensor	Process connection		
0	0	5	5 cm (2")	TMA, TMB	NPT
0	0	6	5,5 cm (2.17")		flanged
0	0	7	7 cm (2.76")		BSP
0	0	6	5,5 cm (2.17")	TMC, TMD	NPT, flanged
0	0	8	7,5 cm (3")		BSP

INSERTION LENGTH – **SELECTABLE** – Specify per cm (0.39") increment

		Sensor	Process connection		
0	0	6	Minimum 6 cm (2.36")	TMA, TMB	NPT
0	0	7	Minimum 7 cm (2.76")		flanged
0	0	8	Minimum 8 cm (3.15")		BSP
0	0	7	Minimum 7 cm (2.76")	TMC, TMD	NPT, flanged
0	0	9	Minimum 9 cm (3.54")		BSP
3	3	0	Maximum 330 cm (130")		all



complete order code for Thermatel® TD1/TD2 STANDARD SENSOR

X = product with a specific customer requirement

DIMENSIONS IN mm (inches) – TMH



PRESSURE/TEMPERATURE RATING – TMH

Maximum process pressure			
@ +40 °C (+100 °F)	@ +120 °C (+250 °F)	@ +200 °C (+400 °F)	@ +450 °C (+850 °F)
414 bar (6000 psi)	339 bar (4920 psi)	295 bar (4280 psi)	233 bar (3380 psi)

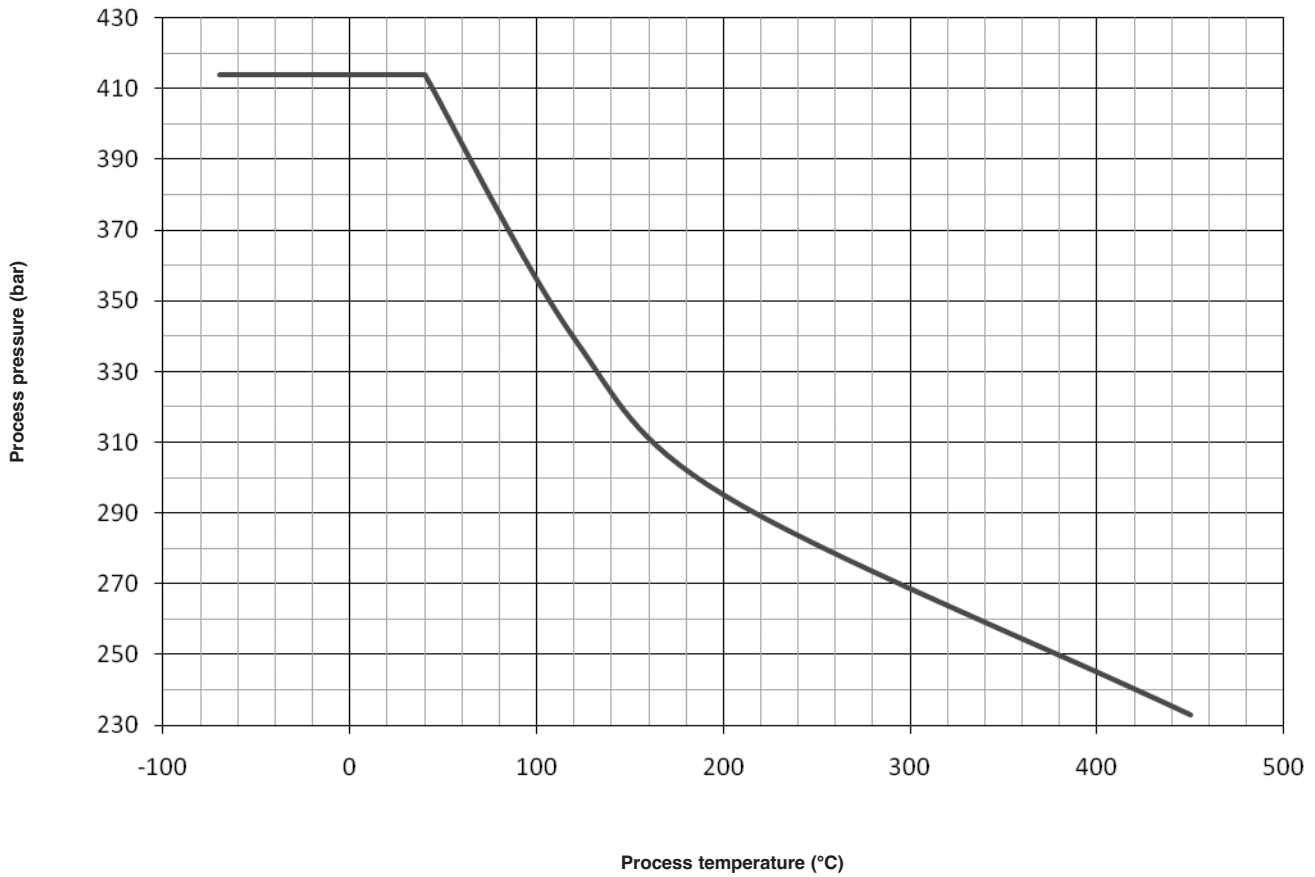

SELECTION DATA (CONT.)

3. Order code for Thermatel® TD1/TD2 – HIGH TEMPERATURE / HIGH PRESSURE SENSOR

1 2 3 | BASIC MODEL NUMBER

T M H	High temperature / high pressure twin tip – max +450 °C (+850 °F) / max 414 bar (6000 psi) ^①
-------	---

^① Not available with retractable probe assembly.

4 | MATERIAL OF CONSTRUCTION FOR SENSOR AND PROCESS CONNECTION

A	316/316L (1.4401/1.4404) stainless steel ^①
B	Hastelloy® C (2.4819)
D	316/316L (1.4401/1.4404) stainless steel
F	Hastelloy® C (2.4819), NACE
K	316/316L (1.4401/1.4404) stainless steel, ASME B31.3
M	316/316L (1.4401/1.4404) stainless steel, ASME B31.3 and NACE
N	316/316L (1.4401/1.4404) stainless steel, NACE

^① Not suitable for zone 0 applications in combination with hermetically sealed relay; use in this case material code D.

5 6 7 | PROCESS CONNECTION – SIZE/TYPE

Threaded

1	1	0	3/4" NPT
2	1	0	1" NPT
2	2	0	1" BSP (G 1")

ASME flanges

2	3	0	1"	150 lbs	ASME RF	3	7	0	1 1/2"	900/1500 lbs	ASME RF
2	4	0	1"	300 lbs	ASME RF	3	8	0	1 1/2"	2500 lbs	ASME RF
2	5	0	1"	600 lbs	ASME RF	4	3	0	2"	150 lbs	ASME RF
2	7	0	1"	900/1500 lbs	ASME RF	4	4	0	2"	300 lbs	ASME RF
3	3	0	1 1/2"	150 lbs	ASME RF	4	5	0	2"	600 lbs	ASME RF
3	4	0	1 1/2"	300 lbs	ASME RF	4	7	0	2"	900/1500 lbs	ASME RF
3	5	0	1 1/2"	600 lbs	ASME RF	4	8	0	2"	2500 lbs	ASME RF

EN flanges

B	B	0	DN 25	PN 16/25/40	EN 1092-1 Type A
B	C	0	DN 25	PN 63/100	EN 1092-1 Type B2
B	G	0	DN 25	PN 250	EN 1092-1 Type B2
C	B	0	DN 40	PN 16/25/40	EN 1092-1 Type A
C	C	0	DN 40	PN 63/100	EN 1092-1 Type B2
C	G	0	DN 40	PN 250	EN 1092-1 Type B2
C	J	0	DN 40	PN 400	EN 1092-1 Type B2
D	A	0	DN 50	PN 16	EN 1092-1 Type A
D	B	0	DN 50	PN 25/40	EN 1092-1 Type A
D	D	0	DN 50	PN 63	EN 1092-1 Type B2
D	E	0	DN 50	PN 100	EN 1092-1 Type B2
D	G	0	DN 50	PN 250	EN 1092-1 Type B2
D	J	0	DN 50	PN 400	EN 1092-1 Type B2

8 9 10 | INSERTION LENGTH – MINIMUM

		Process connection		
0	0	6	5,5 cm (2.17")	NPT
0	0	7	7 cm (2.76")	flanged
0	0	8	7,5 cm (3")	BSP

INSERTION LENGTH – **SELECTABLE** – Specify per cm (0.39") increment

		Process connection		
0	0	7	Minimum 7 cm (2.76")	NPT
0	0	8	Minimum 8 cm (3.15")	flanged
0	0	9	Minimum 9 cm (3.54")	BSP
0	9	1	Maximum 91 cm (36")	all



**complete order code for Thermatel® TD1/TD2
HIGH TEMPERATURE /HIGH PRESSURE SENSOR**

X = product with a specific customer requirement

SELECTION DATA (CONT.)

3. Order code for Thermatel® TD1/TD2 – MINI SENSOR

1 2 3 | BASIC MODEL NUMBER

T	M	M	Mini twin tip – max +120 °C (+250 °F) ^①
---	---	---	--

^① TMM sensors can handle process temperatures up to +200 °C (+400 °F) with remote electronics.

4 | MATERIAL OF CONSTRUCTION FOR SENSOR AND PROCESS CONNECTION

A	316/316L (1.4401/1.4404) stainless steel (CRN Available) ^①
N	316/316L (1.4401/1.4404) stainless steel, NACE (CRN Available)

^① Not suitable for zone 0 applications in combination with hermetically sealed relay.

5 6 7 | PROCESS CONNECTION – SIZE/TYPE

Threaded

0	1	0	1/2" NPT
1	1	0	3/4" NPT
2	1	0	1" NPT

8 9 10 | INSERTION LENGTH – MINIMUM

0	0	3	2,5 cm (1")
---	---	---	-------------

INSERTION LENGTH – **SELECTABLE** – Specify per cm (0.39") increment

0	0	5	Minimum 5 cm (2")
3	3	0	Maximum 330 cm (130")



complete order code for Thermatel® TD1/TD2 MINI SENSOR

X = product with a specific customer requirement

DIMENSIONS IN mm (inches) & PRESSURE/TEMPERATURE RATING – TMM

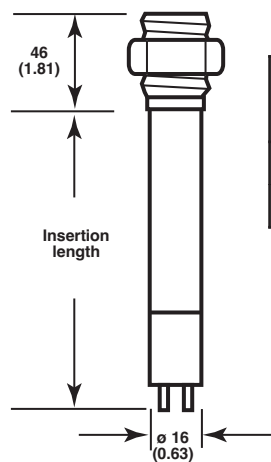

Insertion length	Maximum process pressure		
	@ +40 °C (+100 °F)	@ +120 °C (+250 °F)	@ +200 °C (+400 °F)
= 2,5 cm (1")	207 bar (3000 psi)	170 bar (2460 psi)	148 bar (2140 psi)
> 2,5 cm (1")	128 bar (1850 psi)	105 bar (1517 psi)	91,0 bar (1320 psi)

— Insertion length = minimum length
 - - - - - Insertion length > minimum length

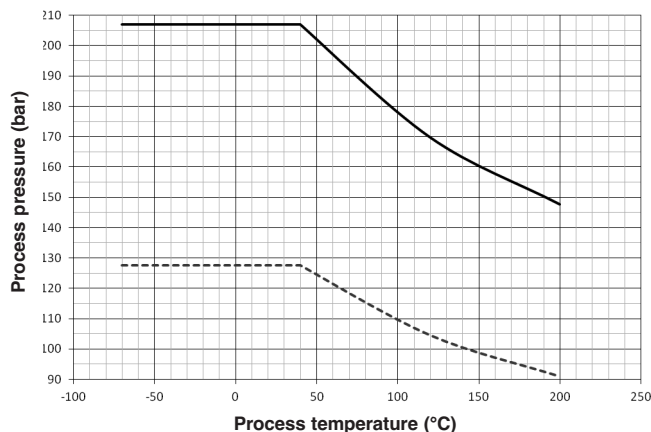

RECOMMENDED FLOW RANGES – TMM

Pipe size	Water	Air
1/2"	0,75 to 680 l/h (0.2 to 180 GPH)	0,85 to 120 Nm ³ /h (0.5 to 70 SCFM)
3/4"	2 to 900 l/h (0.5 to 240 GPH)	2,5 to 170 Nm ³ /h (1.5 to 100 SCFM)
1"	3,8 to 1600 l/h (1 to 420 GPH)	5 to 290 Nm ³ /h (3 to 170 SCFM)

SELECTION DATA (CONT.)

3. Order code for Thermatel® TD1/TD2 – LOW FLOW BODY SENSOR

1 2 3 | BASIC MODEL NUMBER

T	M	L	Low flow body – max +120 °C (+250 °F) ^① / max 400 bar (5800 psi)
---	---	---	---

^① TML sensors can handle process temperatures up to +200 °C (+400 °F) with remote electronics.

4 | MATERIAL OF CONSTRUCTION FOR SENSOR AND PROCESS CONNECTION

A	316/316L (1.4401/1.4404) stainless steel ^①
---	---

^① Not suitable for zone 0 applications in combination with hermetically sealed relay.

5 6 | PROCESS CONNECTION – SIZE/TYPE

Threaded

T	1	1/4" NPT-F (CRN Available)
V	1	1/2" NPT-F (CRN Available)
T	0	1/4" BSP (G 1/4")
V	0	1/2" BSP (G 1/2")

7 | SENSITIVITY

0	Standard
1	High Sensitivity ^①

^① Only available for gas applications and when digit 5 = T.

8 9 10 | MOUNTING BRACKET

0	0	0	None
1	0	0	With carbon steel mounting bracket

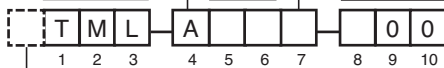

complete order code for Thermatel® TD1/TD2 LOW FLOW BODY SENSOR

X = product with a specific customer requirement

DIMENSIONS IN mm (inches) & PRESSURE/TEMPERATURE RATING – TML

Sensitivity (refer to digit 7)	Maximum process pressure		
	@ +40 °C (+100 °F)	@ +120 °C (+250 °F)	@ +200 °C (+400 °F)
Standard sensitivity	517 bar (7500 psi)	517 bar (7500 psi)	500 bar (7250 psi)
High sensitivity	400 bar (5800psi)	328 bar (4760 psi)	283 bar (4100 psi)

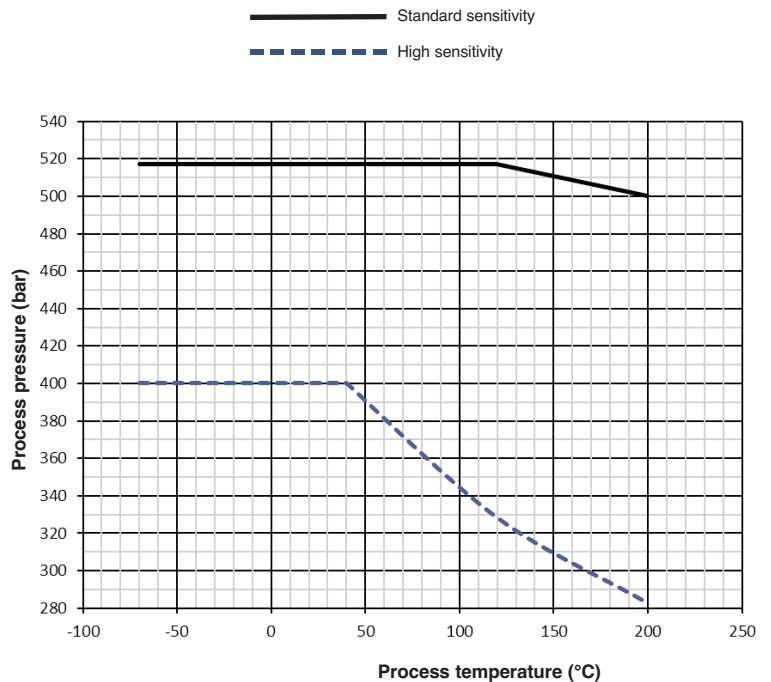
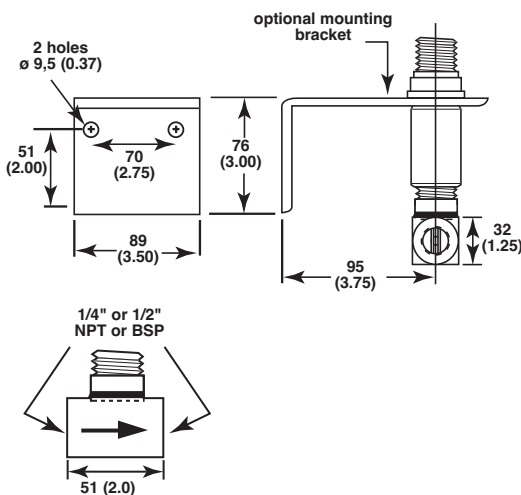

RECOMMENDED FLOW RANGES – TML

Size	Water	Air
1/4" flow body	0,02 to 5,7 l/h (0.0055 to 1.5 GPH)	0,071 to 5,75 Nm ³ /h (2.5 to 200 SCFH) ^①
1/2" flow body	0,04 to 11,5 l/h (0.01 to 3 GPH)	0,071 to 11,5 Nm ³ /h (2.5 to 400 SCFH)

^① For 0,0078 to 0,0708 Nm³/h (0.064 to 2.5 SCFH) use high sensitivity low flow body sensor.

SELECTION DATA (CONT.)

4. Optional sensor mounting flanges

Thread-on mounting flanges can only be used in combination with 3/4" NPT process connection sensor. Consult factory for other sizes or materials.

Thread-on flanges for use with 3/4" NPT-M connections

ASME B16.5 flanges		Part No.		
		Carbon steel	316/316L SST	Hastelloy C
1"	150 lbs RF	004-5867-041	004-5867-043	004-5867-052
1 1/2"	150 lbs RF	004-5867-021	004-5867-001	004-5867-031
2"	150 lbs RF	004-5867-022	004-5867-002	004-5867-032
3"	150 lbs RF	004-5867-023	004-5867-003	004-5867-033
4"	150 lbs RF	004-5867-024	004-5867-004	004-5867-034
6"	150 lbs RF	004-5867-025	004-5867-005	004-5867-035
1"	300 lbs RF	004-5867-042	004-5867-044	004-5867-053
1 1/2"	300 lbs RF	004-5867-026	004-5867-006	004-5867-036
2"	300 lbs RF	004-5867-027	004-5867-007	004-5867-037
3"	300 lbs RF	004-5867-028	004-5867-008	004-5867-038
4"	300 lbs RF	004-5867-029	004-5867-009	004-5867-039
6"	300 lbs RF	004-5867-030	004-5867-010	004-5867-040
1"	600 lbs RF	004-5867-051	004-5867-050	004-5867-054
1 1/2"	600 lbs RF	004-5867-046	004-5867-045	004-5867-055
2"	600 lbs RF	004-5867-049	004-5867-048	004-5867-056

ELECTRONICS SPECIFICATIONS

Description		TD1	TD2
Power supply		19,2 to 28,8 V DC	19,2 to 28,8 V DC 100 to 264 V AC, 50-60 Hz
Power consumption		3,5 W @ 24 V DC	4 W @ 24 V DC or 5 W @ 264 V AC
Flow range	Water	0,01 to 5,0 FPS (0,003 to 1,5 m/s)(spherical tip and twin tip sensors) 0,01 to 1,0 FPS (0,003 to 0,3 m/s)(HTHP, Hastelloy, Monel sensors)	
	Air	0,01 to 500 SFPS (0,03 to 150 Nm/s)	
Output	Alarm	DPDT relay: 8 A @ 120 V AC / 250 V AC 8 A @ 30 V DC; 0,5 A @ 125 V DC	
		Hermetically sealed relay not available	Hermetically sealed DPDT relay: 1A @ 28 V DC; 0,2 A @ 125 V DC
	Continuous	Not applicable	non linear mA for trending (not for all models - see electronics part number on page 7)
	Error	Via alarm relay	3,6 mA (Low Level Fail-safe) – 22 mA (High Level Fail-safe) and alarm relay
Time delay		Not available	0 to 100 s adjustable (in addition to sensor response time)
User interface		- Local switches for gain setting, function setting and High/Low Level Fail-safe - Calibration and time delay via potentiometer	
Display		LED's for Power/Alarm status	2 green LED's (safe condition), 1 yellow LED (alarm setpoint being approached) 1 red LED (alarm condition)
Approvals		ATEX II 2 G Ex db IIC T5..T4 Gb, flameproof enclosure - TD2 for zone 1 ATEX II 1/2 G Ex db+ib, db [ib] IIC T5..T4 Ga/Gb, flameproof enclosure - TD1 & TD2 (TD2 only with 8A DPDT relay) IEC Ex db + ib, db [ib] IIC T5/T4 Gb/Ga - TD1 & TD2 IEC Ex db IIC T5/T4 Gb - TD2 only Other approvals are available, consult factory for more details	
SIL (Safety Integrity Level)		Functional safety to SIL1 as 1oo1 / SIL2 as 1oo2 in accordance to IEC 61508 – SFF of 69,3 % (TD1) and 73 % (TD2) – full FMEDA reports and declaration sheets available	
Housing material		IP66/Aluminium A356T6 (<0.20 % copper) or stainless steel	
Net weight		Aluminium: 1,1 kg (2.4 lbs) - integral electronics only Stainless steel: 2,6 kg (5.7 lbs) - integral electronics only	

PERFORMANCE

Description	Specification
Response time	1-10 s typical (dependent on sensor type, application and set point)
Repeatability	< 1 % @ constant temperature
Ambient temperature	ATEX/IEC Ex d - T4 & non Ex: -40 °C to +70 °C (-40 °F to +160 °F) ATEX/IEC Ex d - T5: -40 °C to +40 °C (-40 °F to +104 °F) Storage: -50 °C to +75 °C (-58 °F to +170 °F)
Humidity	0-99 %, non-condensing
Electromagnetic compatibility	Meets CE requirements (EN 61326: 1997 + A1 + A2)

SENSOR SPECIFICATIONS

Description	Spherical tip - Twin tip sensors TMA/TMB - TMC/TMD	HTHP sensor TMH
Materials	316/316L (1.4401/1.4404) Hastelloy® C (2.4819) – TMC/TMD only Monel® (2.4360) – TMC/TMD only	316/316L (1.4401/1.4404) Hastelloy® C (2.4819)
Sensor diameter	22,9 mm (0.90")	21,9 mm (0.86")
Process connection	Threaded: NPT or BSP Flanged: various ASME or EN flanges	
Sensor length	5 - 330 cm (2" - 130")	5,5 - 91 cm (2.17" - 36")
Process temperature	TMA/TMC ^① : -70 °C to +120 °C (-100 °F to +250 °F) TMB/TMD: -70 °C to +200 °C (-100 °F to +400 °F)	-70 °C to +450 °C (-100 °F to +850 °F)
Max process pressure	See info on page 8	See info on page 10

① Use remote electronics (TD2) for temperatures > +120 °C (+250 °F) up to max +200 °C (+400 °F) or sensors with heat extension (TMB/TMD) when using integral electronics.

Description	Mini twin tip sensor TMM	Low flow body TML
Materials	316/316L (1.4401/1.4404)	
Sensor diameter	16 mm (0.63")	1/4" or 1/2" pipe size
Process connection	Threaded: 1/2", 3/4" or 1" NPT	Threaded: 1/4" or 1/2" NPT-F or BSP
Sensor length	2,5 - 330 cm (1" - 130")	Not applicable
Process temperature	-70 °C to +120 °C (-100 °F to +250 °F) ^①	
Max process pressure	See info on page 12	See info on page 13

① Use remote electronics (TD2) for temperatures > +120 °C (+250 °F) up to max +200 °C (+400 °F).

DIMENSIONS IN mm (inches)

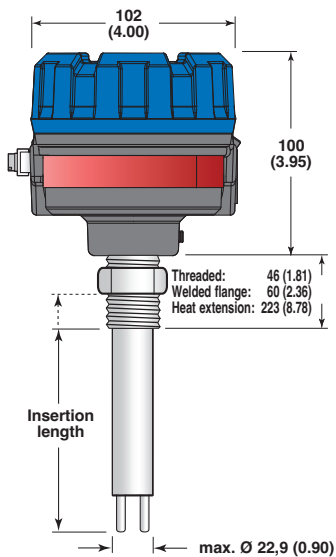

Model TD1 with TMC/TMD twin tip sensor

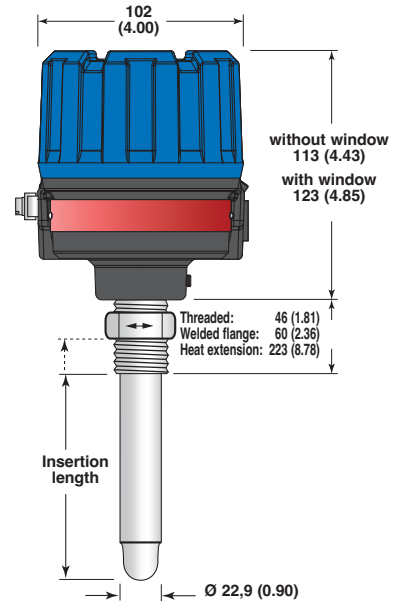

Model TD2 with integral electronics and TMA/TMB spherical tip sensor

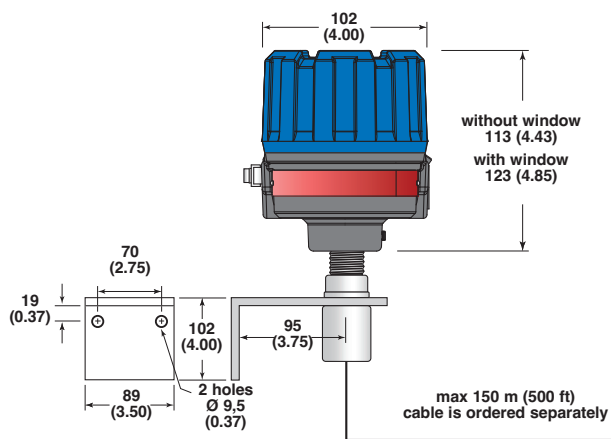

Model TD2 with remote electronics

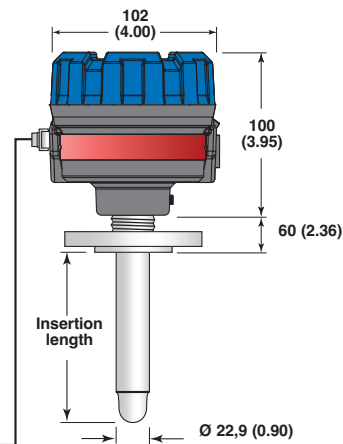

Remote TMA spherical tip sensor with flanged connection

QUALITY ASSURANCE - ISO 9001

THE QUALITY ASSURANCE SYSTEM IN PLACE AT MAGNETROL GUARANTEES THE HIGHEST LEVEL OF QUALITY DURING THE DESIGN, THE CONSTRUCTION AND THE SERVICE OF CONTROLS. OUR QUALITY ASSURANCE SYSTEM IS APPROVED AND CERTIFIED TO ISO 9001 AND OUR TOTAL COMPANY IS COMMITTED TO PROVIDING FULL CUSTOMER SATISFACTION BOTH IN QUALITY PRODUCTS AND QUALITY SERVICE.

PRODUCT WARRANTY

ALL MAGNETROL ELECTRONIC AND ULTRASONIC LEVEL CONTROLS ARE WARRANTED FREE OF DEFECTS IN MATERIALS AND WORKMANSHIP FOR 18 MONTHS FROM THE DATE OF ORIGINAL FACTORY SHIPMENT. IF RETURNED WITHIN THE WARRANTY PERIOD; AND, UPON FACTORY INSPECTION OF THE CONTROL, THE CAUSE OF THE CLAIM IS DETERMINED TO BE COVERED UNDER THE WARRANTY; THEN, MAGNETROL INTERNATIONAL WILL REPAIR OR REPLACE THE CONTROL AT NO COST TO THE PURCHASER (OR OWNER) OTHER THAN TRANSPORTATION. MAGNETROL SHALL NOT BE LIABLE FOR MISAPPLICATION, LABOR CLAIMS, DIRECT OR CONSEQUENTIAL DAMAGE OR EXPENSE ARISING FROM THE INSTALLATION OR USE OF THE EQUIPMENT. THERE ARE NO OTHER WARRANTIES EXPRESSED OR IMPLIED, EXCEPT, SPECIAL WRITTEN WARRANTIES COVERING SOME MAGNETROL PRODUCTS.

BULLETIN N°:
EFFECTIVE:
SUPERSEDES:

BE 54-110.10
JULY 2021
June 2019

UNDER RESERVE OF MODIFICATIONS

European Headquarters & Manufacturing Facility

Heikensstraat 6
9240 Zele, Belgium
Tel: +32-(0)52-45.11.11
e-mail: info.magnetrolbe@ametek.com

www.ametek-measurement.com



MAGNETROL®

AMETEK®