

USER MANUAL

S300 Series Dust Monitors

Models S303 and S304



Document information

Revision	6
Publication date:	2021-05-03
Device series:	S300
Applicable products:	S303, S304
Original language:	en-US

Trademarks

Modbus is a registered trademark of Schneider Electric USA Inc.

Legal disclaimer

Seller hereby disclaims any and all warranties and representations (express or implied, oral or written), including any and all implied warranties of merchantability or fitness for any purpose whether or not seller knows, or has reason to know, has been advised, or is otherwise in fact aware of any such purpose, whether alleged to arise by law, by reason of custom or usage in the trade, or by course of dealing or performance.

Purchaser understands and agrees that it shall be purchaser's sole responsibility to ensure that all products obtained from seller shall adhere to applicable laws, codes and standards within the territory of use. Purchaser absolves and holds seller harmless for any alleged violations of such local laws, codes, and standards within the territory of use.

Copyright

Subject to change without notice.
All rights reserved. ©2021 Sintrol.

Contents

1 About this manual	7
1.1 Description of symbols.....	7
1.2 Abbreviations	8
2 Safety	9
2.1 Warnings	9
2.2 Intended use	10
2.3 Use in potentially explosive atmospheres	11
2.4 Conformity to standards and directives	11
3 Product overview	12
3.1 Product description.....	12
3.1.1 Key properties	12
3.1.2 Commissioning	12
3.1.3 Installation.....	13
3.1.4 Settings and parameters	13
3.2 Design drawings	13
3.2.1 Dimension drawings.....	15
3.2.2 Identification	17
3.3 Scope of delivery	18
3.4 Features and accessories	19
3.4.1 Standard features.....	19
3.4.2 Optional features and accessories	19
3.5 Operating principle	23
3.5.1 Inductive Electrification Unit.....	23
3.5.2 Potential influences on measurement results	23
4 Storage	28
5 Mechanical installation	29
5.1 Unpacking and inspection	29
5.1.1 Unpacking.....	29
5.1.2 Inspection	29
5.2 Selecting installation location	29
5.2.1 Ambient environment.....	30

5.2.2 Vibration	30
5.2.3 Location.....	30
5.2.4 Orientation.....	31
5.2.5 Probe length.....	31
5.2.6 Position	32
5.2.7 Duct pressure	33
5.2.8 Process temperature	34
5.3 Installing sensor	34
5.3.1 Safety precautions	34
5.3.2 Installation	35
6 Electrical installation.....	40
6.1 Electrical safety	40
6.2 Cable types.....	41
6.3 Electrical connections	42
6.3.1 Main board.....	42
6.3.2 Terminal blocks	43
6.3.3 Grounding	43
6.3.4 Power supply.....	48
6.3.5 Relays	52
6.3.6 Analog mA output.....	55
6.3.7 RS-485 buses	59
6.3.8 Connecting with USB.....	66
6.3.9 Analog mA input	67
7 DustTool	71
7.1 Overview	71
7.2 System requirements.....	71
7.3 Main view.....	71
8 Commissioning and system setup.....	73
8.1 Auto setup.....	73
8.1.1 Overview	73
8.1.2 Operation statuses.....	73
8.1.3 Performing Auto Setup	75
8.2 Changing parameters.....	76

8.2.1 Main interface	76
8.2.2 DustTool software	77
8.2.3 Modbus RTU and Sintrol Network protocol	77
8.2.4 Wireless connection	78
8.3 Setting up device network	78
8.3.1 Naming devices	79
8.3.2 Wired device network	79
8.3.3 Wireless device network	81
8.3.4 Combining wired and wireless connections in a network	83
9 Operation	84
9.1 Main interface	84
9.2 Relay, LED and display functional logic	85
9.2.1 Operation statuses	85
9.2.2 Relay logic	85
9.2.3 LED and display logic	87
9.3 Parameters	87
9.3.1 Overview	87
9.3.2 Parameter 1: Display unit	89
9.3.3 Parameter 2: Signal averaging time	89
9.3.4 Parameter 3: Measurement range	90
9.3.5 Parameter 4: ALERT threshold	91
9.3.6 Parameter 5: ALARM threshold	91
9.3.7 Parameter 6: Alarm delay time	92
9.3.8 Parameters 7 and 8: Flow velocity compensation	92
9.3.9 Parameter 9: Zero/span check interval	93
9.3.10 Parameter 10: Command parameter	93
9.3.11 Parameters 11 to 14: Displaying measurement results in mg/m ³	95
9.3.12 Parameters 15 and 16: IEU to 20 mA scaling	97
9.3.13 Parameter 17: Firmware version	98
9.4 Troubleshooting	99
9.4.1 Error codes in FAULT mode	99
9.4.2 Display indicates “- - - -”	101
9.4.3 Display indicates “[n] - - -”	102









9.4.4 No output signal.....	102
9.4.5 No response after Auto Setup	102
9.4.6 Device lid does not open	103
10 Maintenance and inspection	104
10.1 Safety precautions	104
10.2 Maintenance and inspection interval	105
10.3 Maintenance and inspection	105
10.3.1 Removing device from the process	106
10.3.2 Cleaning supplies	108
10.3.3 Maintenance of Teflon-coated probe.....	108
10.4 Returns.....	108
11 Recycling and disposal	109
11.1 Packaging	109
11.2 Device.....	109
12 Specifications.....	110
Appendix A: ISO 9001 certificate	112
Appendix B: Modbus RTU registers	113
Notes	115







1 About this manual

This user manual contains the installation, commissioning, operating and maintenance instructions for S300 series dust monitor models S303 and S304. Read this manual carefully before using the device. This manual is an important part of the product, and it must always be available for reference to all personnel installing, commissioning, operating or performing maintenance on the device. In case the manual is lost or damaged, request a new copy from the manufacturer or an authorized distributor.

1.1 Description of symbols

These symbols are used to alert you to any potential personal injury hazards, and to provide information on how to avoid them. Obey all safety messages that use these symbols to avoid possible injury or death. Symbols that provide additional information about using and handling the product are also described here.

Symbol	Description
	General warning symbol.
	Hot surface.
	Electric hazard.
	Toxic hazard.
	Explosion hazard.
	Important or useful information related to installing, maintaining or operating the device.
	Read the user manual before doing a procedure or operating the device.
	Wear protective gloves.

Symbol	Description
	Wear protective glasses.
	Wear protective overalls.
	Wear a welding mask.
	Wear respiratory protection.
	CE marking indicates that the device has been designed and manufactured to meet all applicable health, safety and environmental protection standards required for products sold in the European Union.
	Electronic devices that are marked with this symbol must not be disposed of with general waste. If a defective or broken-down device cannot be repaired, it must be recycled and disposed of in accordance with WEEE directive (2012/19/EU) or other applicable local regulations.
	This symbol indicates waste material that must be recycled.

1.2 Abbreviations

Abbreviation	Explanation
ESP	Electrostatic precipitator
ID	Inside diameter
IEU	Inductive electrification unit
MB	Modbus
OD	Outside diameter
RF	Radio frequency
RH	Relative humidity
SNT	Sintrol Network
SPDT	Single pole double throw
TSP	Total suspended particles

2 Safety



**Read this chapter carefully before handling the device in any way.
In addition, read all safety notes before work steps and other instructions.**

Only trained and qualified personnel can install, commission, operate and perform maintenance on the device. All personnel must read and understand this manual and follow its instructions accurately. Failure to follow the safety instructions and safety precautions could result in serious injury or death.

If you encounter any unexpected situations during the intended use of the device that are not described in this manual, contact the manufacturer or an authorized distributor.

In addition to the safety instructions described in this manual, the personnel using the device must follow all applicable country- and industry-specific safety standards and regulations.

2.1 Warnings



DANGER!

“DANGER” indicates a hazard with a high level of risk, which will result in death or serious injury if not avoided.



WARNING!

“WARNING” indicates a hazard with a medium level of risk, which can result in death or serious injury if not avoided.



CAUTION!

“CAUTION” indicates a hazard with a low level of risk, which can result in minor or moderate injury if not avoided.

NOTICE

“NOTICE” indicates a situation with a risk of equipment damage.

2.2 Intended use

This device is designed for measuring total suspended particles (TSP) in the airflow inside conductive pipes and ducts. The intended use is as described in this user manual. Any other use is considered improper and can result in injury or equipment damage.



The manufacturer or distributor cannot be held liable for any damage, injury or financial loss resulting from improper use.

The device must not be modified or repaired in any way that is not specifically described in this manual. Do not perform any mechanical or electrical repairs without contacting the manufacturer or an authorized distributor.

Only original Sintrol parts can be used for repairs. If third-party spare parts are used, the manufacturer cannot guarantee safe operation of the device.

Before installing and commissioning the device, carefully inspect it for any damage or defects. Do not use the device if it is damaged, or if the power supply is defective. Return damaged device to the manufacturer or an authorized distributor.

Non-compliance with any of these conditions immediately voids the warranty, and the manufacturer's responsibility no longer applies.



Wear appropriate protective gloves at all times when installing the device.

DANGER!



Explosion hazard

The device is not UL/CSA or IECEx/ATEX certified. Do not use the device in potentially explosive atmospheres.

WARNING!



Use in critical applications

Improper use in critical applications can lead to hazardous situations or have severe adverse health effects. Such critical applications include, but are not limited to:

- **Health protection**
- **Emission monitoring**
- **Process control**
- **Fire and explosion prevention**

Many factors can affect the operation of the dust monitoring system. These factors can include, for example, dust particle size, dust material, the design of the pipes or ducts that the dust monitor is installed on, and operator error. Because of this, an industry specialist must evaluate and approve the suitability of Sintrol products for any given dust monitoring system. This is particularly true when the instruments are only a component in a larger monitoring system, or when they are used in critical applications.

2.3 Use in potentially explosive atmospheres

DANGER!



Explosion hazard

The device is not UL/CSA or IECEx/ATEX certified. Do not use the device in potentially explosive atmospheres.

An ATEX-certified model of the device is available. Only ATEX-certified models can be used in potentially explosive atmospheres.



If you have ordered ATEX-certified device, read the supplementary ATEX safety instructions carefully before installing, commissioning, operating or performing maintenance on the device.

2.4 Conformity to standards and directives

This device has been designed and manufactured to comply with the requirements of ISO 9001:2015 standard related to quality management. See **Appendix A**: ISO 9001 for ISO 9001 certificate.

This device has been designed and manufactured to comply with the following standards and directives:

- EN 61010-1:2010
- EN 61326-1:2012
- ROHS Directive 2011/65/EU (RoHS II)

3 Product overview

3.1 Product description

The device is designed to measure the concentration of dust particles inside a pipe or duct. It is an ideal solution for industrial applications like filter leak detection, air circulation control and emission monitoring.

The operating principle is based on inductive electrification technology, where particles interacting with an isolated probe induce a signal that is transmitted to the monitoring system. The normal dust level is determined during commissioning, and the signal generated by the sensor is then scaled in proportion to this baseline level when the dust level fluctuates.



The device is intended for use in non-condensing environments. The sensor does not distinguish liquid droplets from dust particles. If the measured airflow contains liquid droplets, the measurement results are inaccurate.

The device has a local user interface with four keys and a 7-segment display with four digits for local setup, status indication and changing parameters.

For detailed technical data, see chapter **Specifications**.

3.1.1 Key properties

Table 1: Key properties of a standard device

Enclosure:	Aluminum
Probe length:	500 mm (19.68 in)
Probe material:	Stainless steel (316L)
Insulation material:	Polyphenylene sulfide (Ryton R-4)
Output signal:	4 ... 20 mA
Max. temperature:	300 °C (572 °F)
Max. pressure:	600 kPa (87.02 psi)
Flow velocity:	Min. 3 m/s (9.84 ft/s), max. tested 40 m/s (131.23 ft/s)

3.1.2 Commissioning

Commissioning is easy with Auto Setup feature, which determines the baseline dust level and sets up two alarm thresholds that are proportional to the baseline. An alarm is triggered when the dust concentration exceeds a configured threshold.

3.1.3 Installation

For installation, the device is equipped with a quick-clamp connector between the instrument and the weld-on process connection.

3.1.4 Settings and parameters

You can access and change the device settings and parameters with the local display that has four keys and a 7-segment display with four digits. Additionally, you can connect the device to a computer using USB, RS-485 bus or an optional radio frequency (RF) communication protocol, and change the parameters using complementary DustTool software. You can download DustTool free of charge at <https://sintrol.com/product/dusttool/>.

3.2 Design drawings

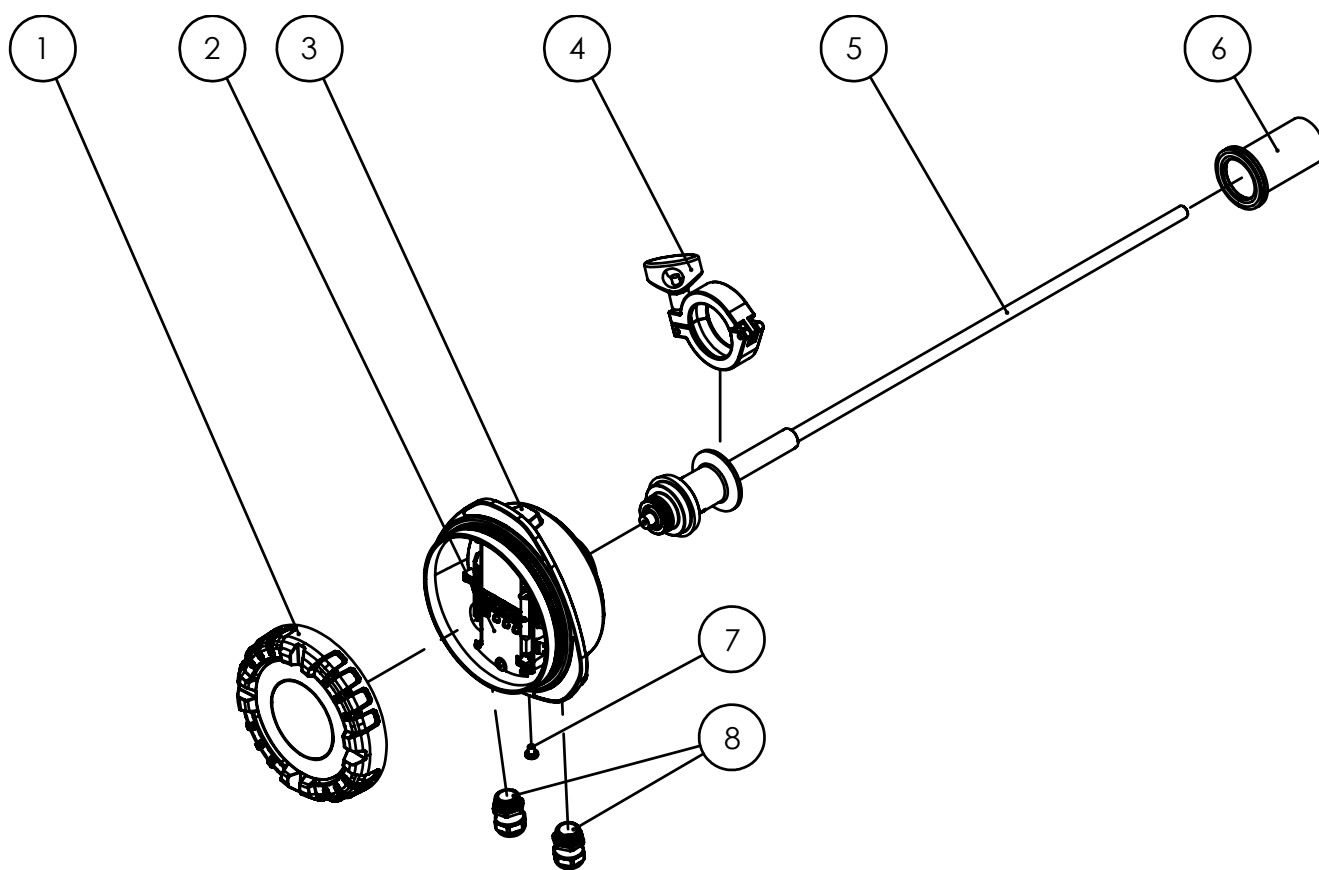

Figure 1: Main components of the dust monitor

① Threaded lid with a window	⑤ Sensor probe
② Main board and interface	⑥ Process connection
③ Aluminum enclosure	⑦ External ground connection
④ Quick-clamp connector	⑧ PG11 cable glands

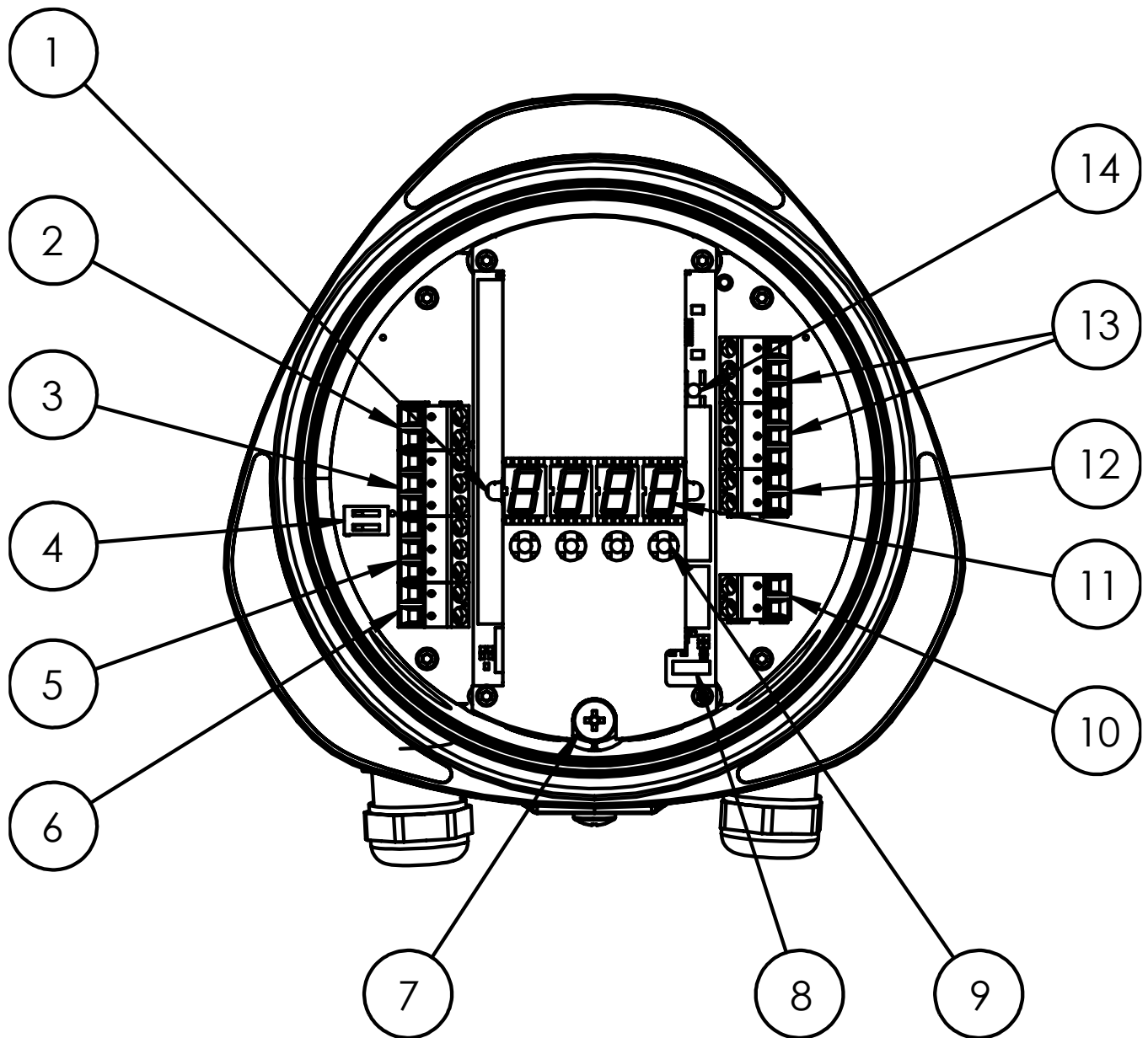

Figure 2: Main interface and electrical connections of the dust monitor

① Status LED	⑧ Micro-B USB port
② Analog mA output	⑨ Navigation keys
③ RS-485 bus (Modbus RTU)	⑩ 24 V DC power supply terminal
④ RS-485 terminator switch	⑪ 7-segment displays
⑤ RS-485 bus (Sintrol Network)	⑫ 100 ... 240 V AC power supply terminal
⑥ Analog mA input*	⑬ Relay terminals
⑦ Internal ground connection	⑭ Auto Setup key

* Only functional in model S304.

3.2.1 Dimension drawings

Dust monitor side view

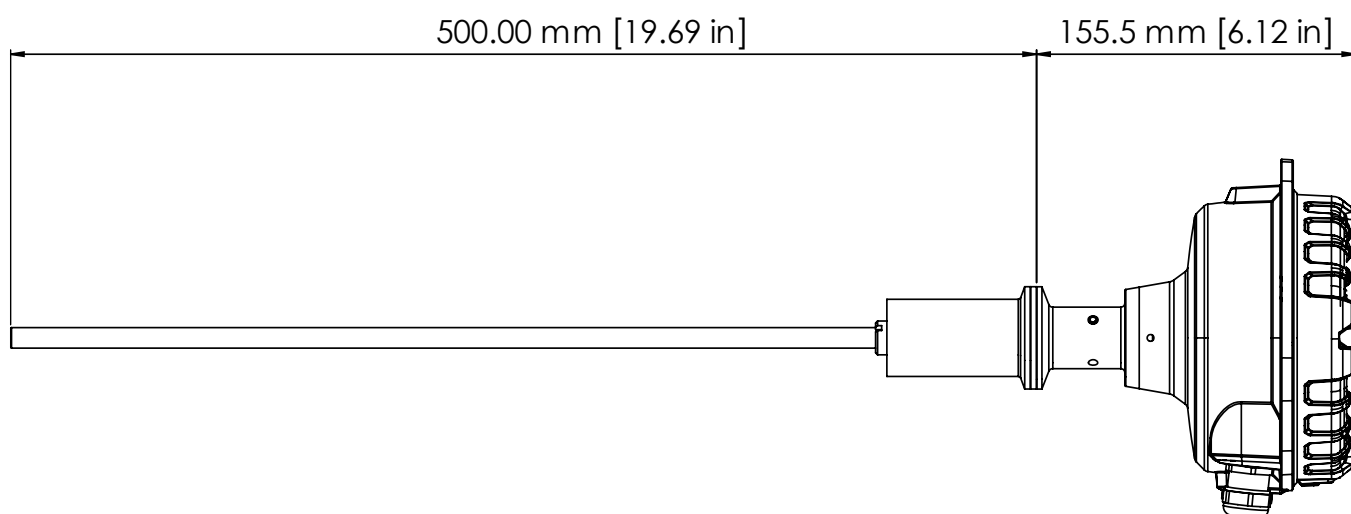

Figure 3: Side view dimensions of the enclosure and probe

Dust monitor front view

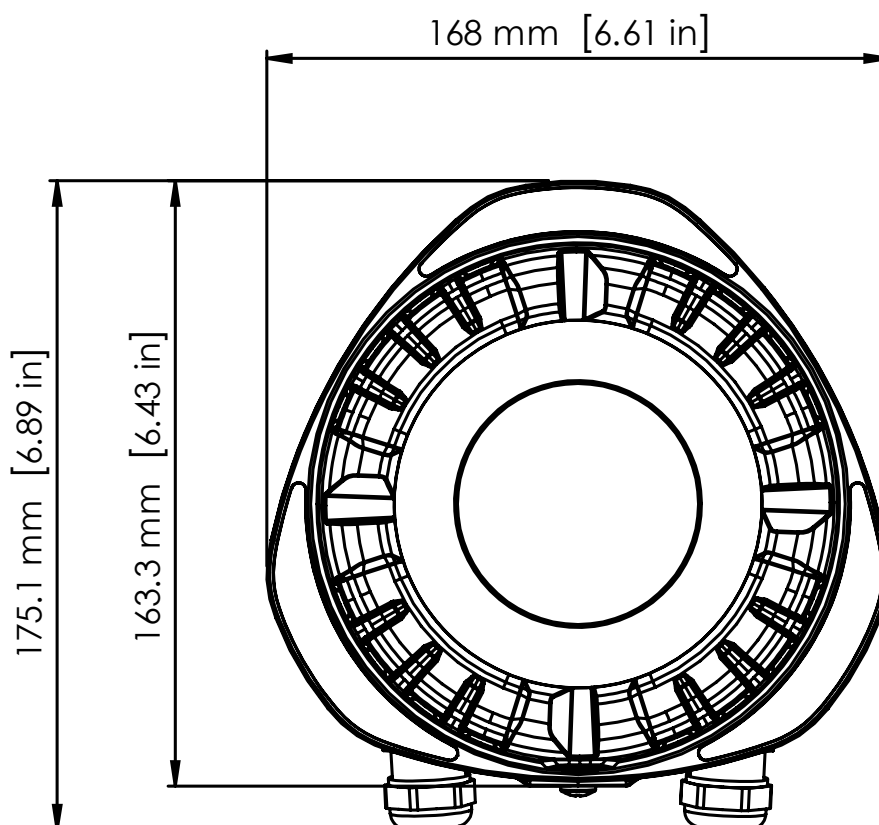

Figure 4: Front view dimensions of the enclosure

Process connection side view

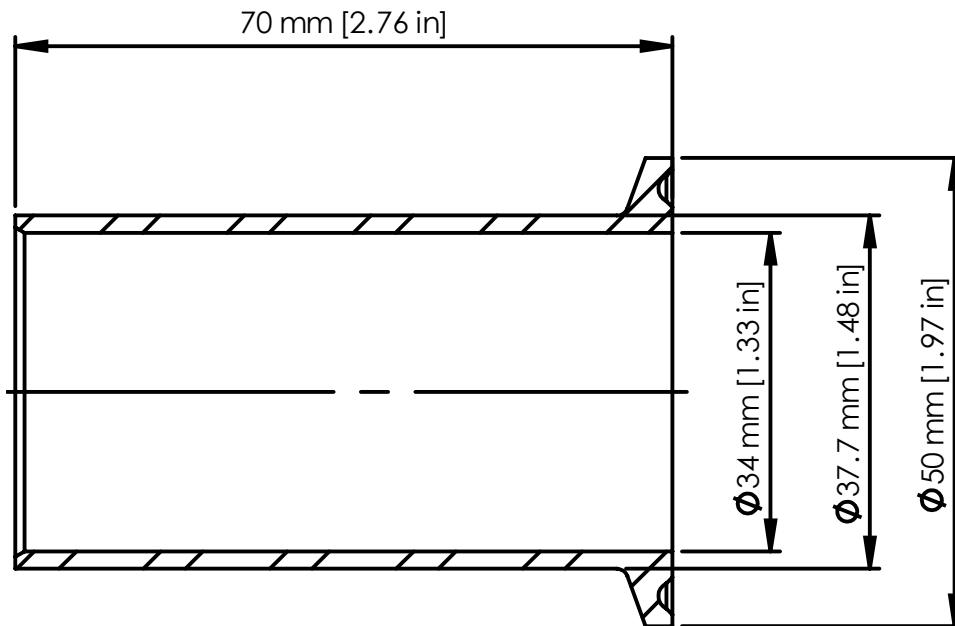

Figure 5: Process connection dimensions

Optional accessories

For part numbers and additional details about optional accessories, see section **Optional features and accessories**.

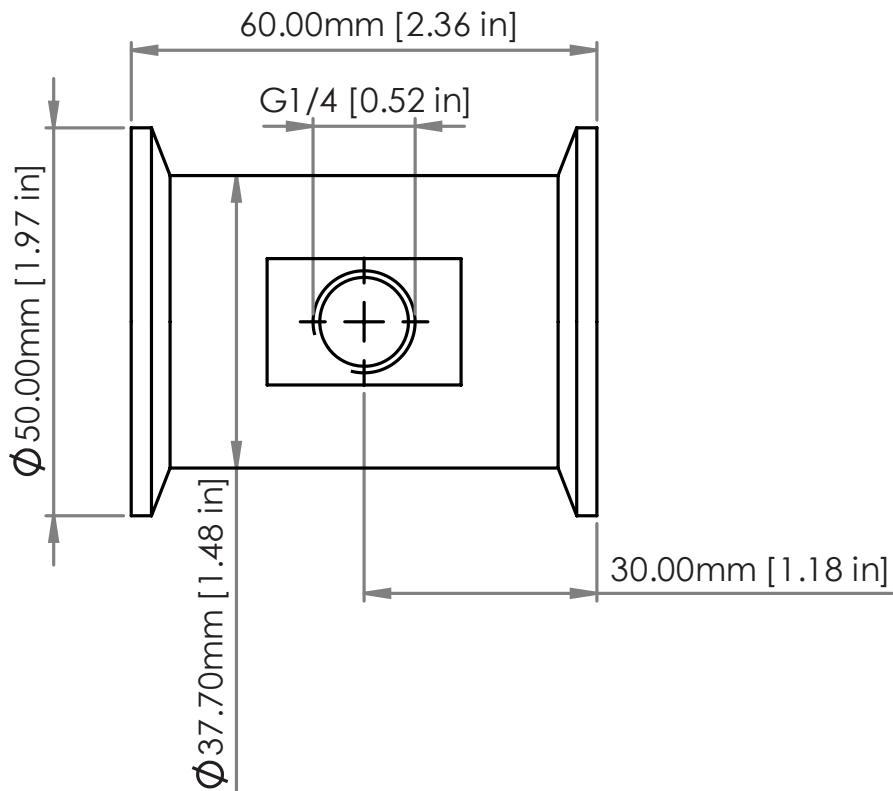

Figure 6: Air purge adapter dimensions

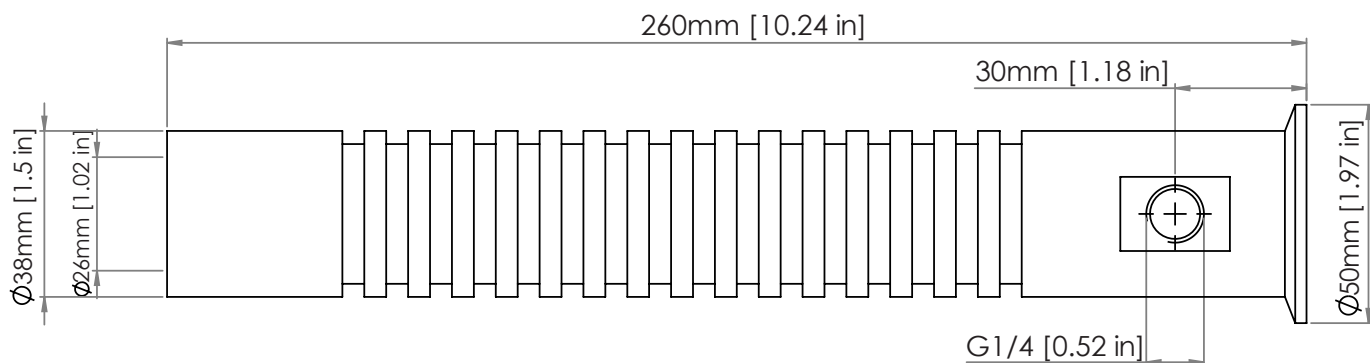

Figure 7: High-temperature process connection dimensions

3.2.2 Identification

Identification label is located on the backside of the device, under the sensor probe.

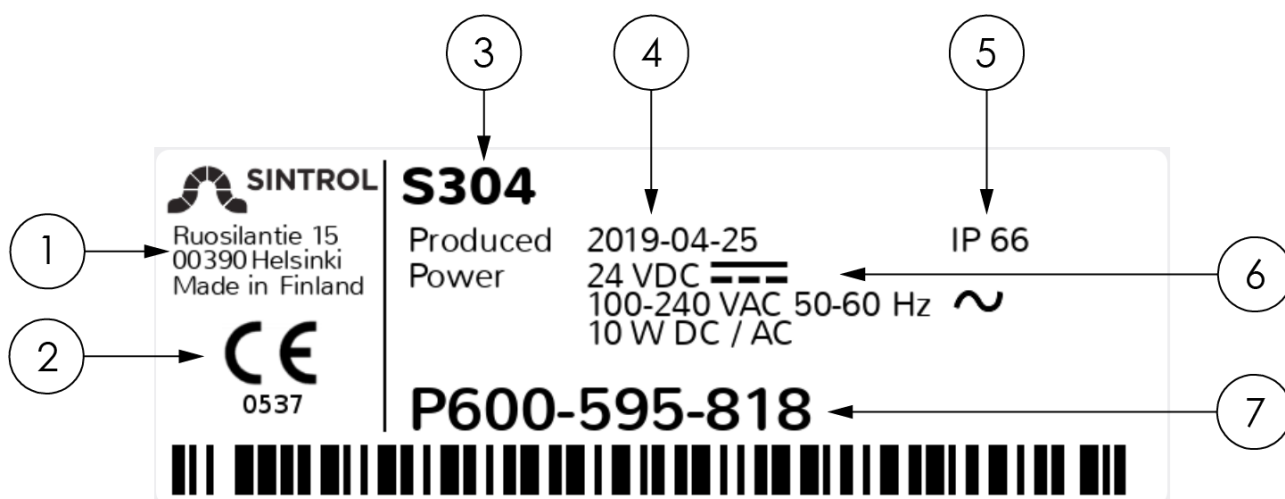

Figure 8: Identification label

①	Manufacturer details	⑤	IP rating
②	CE marking	⑥	Power supply specifications and power consumption
③	Device model	⑦	Serial number
④	Production date		

3.3 Scope of delivery

A standard delivery includes the following components:

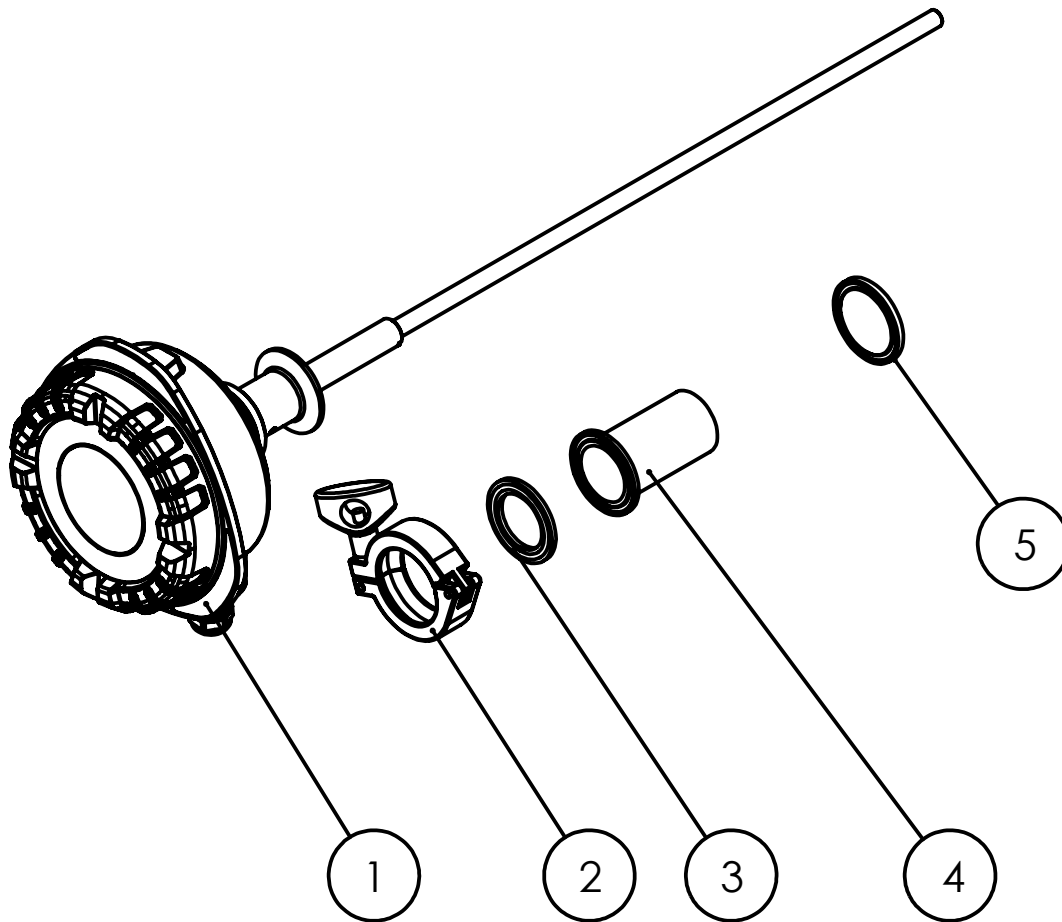

Figure 9: Components included in a standard delivery

①	Dust monitor	④	Weld-on process connection Part number: MC900229
②	Quick-clamp connector Part number: MC900034	⑤	End cap for process connection Part number: MC900033
③	Quick-clamp gasket Part number: OC900007		

When delivered, the device is already assembled with the process connection secured to the sensor probe with the quick-clamp connector. Disconnect the sensor from the process connection before installation.

End cap is used to seal the process connection when the device is removed from the process for inspection and maintenance.

3.4 Features and accessories

3.4.1 Standard features

A standard delivery includes the following features:

Table 2: Comparison of standard features between dust monitor models

Feature	√=Standard	×=Not available	○=Optional	S303	S304
Rugged IP66-rated pressure-casted aluminum enclosure				✓	✓
Weld-on process connection and quick-clamp for easy installation				✓	✓
Green, yellow* and red LEDs for status indication				✓	✓
Auto Setup function for easy commissioning				✓	✓
Two dry-contact relays to indicate dust alert and dust alarm				✓	✓
Inputs for 24 V DC and 240 V AC power supply				✓	✓
USB interface				✓	✓
DustTool software for easy calibration and setup				✓	✓
RS-485 bus (MB) for integration into existing control systems using Modbus RTU, and for connecting multiple devices in parallel using Modbus RTU or Sintrol Network protocol				✓	✓
RS-485 bus (SNT) for single-device communication using Sintrol Network protocol				✓	✓
Main interface with four keys and a 7-segment display with four digits for local setup and status indication				✓	✓
Active and isolated 4 ... 20 mA output in accordance with NAMUR NE43				✓	✓
Zero/span check with automatic drift compensation				✓	✓
Possibility to program the display to show dust concentrations in mg/m ³				×	✓
Flow velocity compensation using an external flowmeter				×	✓
Wireless network capability to reduce cabling costs**				○	○

* When green and red LEDs are ON at the same time, the color appears yellow or orange

** Requires radio frequency (RF) model. RF antenna cannot be retrofitted to non-RF models.

3.4.2 Optional features and accessories

The device can be customized to meet the specific requirements for various applications and process conditions.

Probe coating

The sensor probe can be equipped with a protective coating. The standard probe has no protective coating, and it can be used in process temperatures up to 300 °C (572 °F). Optional coatings for the sensor probe are:

Teflon	For wet conditions with up to 250 °C (482 °F) process temperature in non-hazardous areas.
Diamond	For abrasive and dry processes.
Salocote enamel	For wet conditions with up to 700 °C (1292 °F) process temperature. Maximum length 500 mm (19.69 in).

For processes with temperatures over 300 °C (572 °F), the device must be equipped with a high-temperature process connection that protects the probe insulation from heat damage.

Probe length

Standard probe length is 500 mm, and it can be extended in 250 mm increments up to 1500 mm. Probe length can also be customized more accurately according to client specifications. Contact the manufacturer or an authorized distributor for details about non-standard probe lengths for coated probes.

The recommended minimum probe length depends on the measuring conditions and environment. If the probe is too short compared to the duct diameter, the measurement results are inaccurate.

Recommended probe lengths are as follows:

- For indicative monitoring, a minimum probe length of one fourth ($\frac{1}{4}$) of the duct diameter is recommended.
- For demanding and critical applications with varying flow velocity, a minimum probe length of one third ($\frac{1}{3}$) of the duct diameter is recommended.

Air purge adapter

Part number: MC900203

Air purge is an additional feature for applications where adhesive or conductive dust buildup can cause interference on the measurement results. The air purge adapter is installed between the standard probe and process connection, and secured in place with an additional quick-clamp.

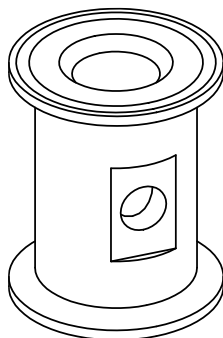

Figure 10: Air purge adapter with $\frac{1}{4}$ -inch G-thread connection

Equipping the device with the air purge adapter is recommended in the following operating conditions:

- Extremely high dust concentrations. Dust buildup on the sensor probe will influence the measurement results.

- Unstable process temperature. A drop in the process temperature can cause condensation on the sensor probe, which will influence the measurement results.
- High relative humidity. High humidity can cause condensation on the base of the sensor, which will influence the measurement results.

Air purge creates a continuous airflow around the probe that ensures that the base of the probe stays clean of dust buildup, and that it can provide accurate measurement results. The recommended air supply uses clean, dry and oil-free instrument air. Recommended airflow is 50 l/min \pm 10%, and the required air pressure depends on the flow resistance and process pressure. Adjust the airflow in the actual application.

The air purge adapter has a $\frac{1}{4}$ -inch G-thread connection for connecting an inlet air hose that has a $\frac{1}{4}$ -inch R-thread connector. Devices ordered with the air purge option are delivered with an additional quick-clamp and quick-clamp gasket.



Incorrectly installed or configured air purge adapter can cause interference on the measurement response. This can result in incorrect measurement results or, in the worst case, interrupt the operation of the device.

For air purge dimensions, see section **Dimension drawings**.

High-temperature process connection

Part number: MC901165

A standard probe can be used in process temperatures up to 300 °C (572 °F). Optionally, the dust monitor can be equipped with a probe that can withstand process temperatures of up to 700 °C (1292 °F).

For processes with temperatures over 300 °C (572 °F), the device must be equipped with a high-temperature process connection that protects the probe insulation from heat damage.

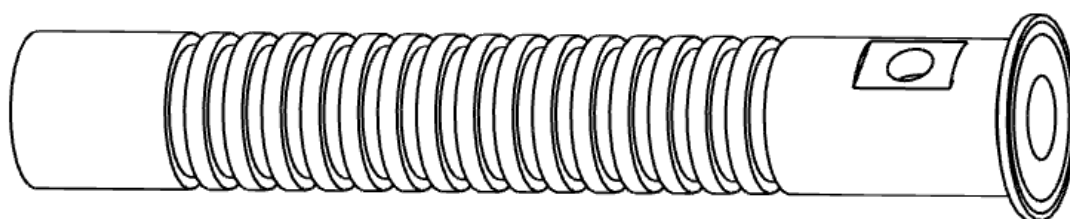

Figure 11: High-temperature process connection

High-temperature process connection is longer than the standard process connection, which increases the distance between the probe insulation and the heat source. This helps protect the probe insulation and the device from heat damage.

Additionally, high temperature process connection has a $\frac{1}{4}$ -inch G-thread connection for connecting an inlet air hose that has a $\frac{1}{4}$ -inch R-thread connector. This connection is used for air purge function, which helps keep the base of the probe clean of dust buildup and cools down the probe. The recommended air supply uses clean, dry and oil-free instrument air. Recommended airflow is at least 50 l/min \pm 10%, and

the required air pressure depends on the flow resistance and process pressure. Adjust the airflow in the actual application.

NOTICE

Maximum process pressure with a high-temperature process connection is 300 kPa (43.51 psi).

For dimensions, see section **Dimension drawings**.

Flange connection

The standard installation with the weld-on process connection is suitable for all conditions where the device can be used. However, the device can be ordered with an optional flange connection.

Flange connection only changes the way that the device is connected to the process. The device is secured to the flange connection with the quick-clamp, and the receiving pipe or duct must have a suitable counter flange.

The flange connection is available in different sizes and configurations according to client specifications.

Wireless communication

A standard device communicates with a monitoring system or PC with signals that are transmitted through physical wires. The device can be equipped with a radio frequency (RF) antenna to enable wireless communication.



The device must be ordered with RF capability. Non-RF models cannot be retrofitted with the RF antenna after delivery.

Accessories

The device can be ordered with the following optional accessories:

RS-485 to USB converter for connecting the device to a computer using Sintrol Network protocol.

Part number: EC900041



Network Router for setting up device chains and networks.

Part number: PC900091



Wireless Router for setting up wireless device networks.

Part number: PC900090



DustLog 10 reporting software for additional data logging and reporting options.

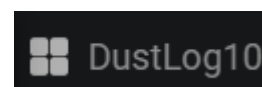

3.5 Operating principle

The device is designed for measuring total suspended particles (TSP) in the airflow inside conductive pipes and ducts. A complete installation consists of an isolated probe that is inserted inside a duct, perpendicular to the airflow.

When dust particles moving inside the duct pass or hit the sensor probe, a signal is induced. This signal is then transferred to a monitoring system, for example a computer running a monitoring software. The underlying technology is called “inductive electrification”. This technology is very sensitive, and it minimizes the influence that sensor contamination, changes in process temperature and flow velocity have on the measurement results.

Inductive electrification technology enables a detection limit of as low as 0.01 mg/m^3 .

3.5.1 Inductive Electrification Unit

The signal level generated by the device is measured in Inductive Electrification Units (IEU), and the IEU value is converted to mA output signal that the device uses to communicate the dust level to the monitoring system. The IEU value can be anything from a few hundred up to several million units, which allows the relation between the IEU value and mA signal to be set very accurately.

The relation between the IEU value and mA output signal is established automatically with the Auto Setup function. With model S304, it is also possible to display the measurement results in mg/m^3 . However, in this case the IEU value and output signal must be calibrated against a reference, for example the results of gravimetric analysis.

3.5.2 Potential influences on measurement results

With the inductive electrification technology, the signal level shows the following behavior over the measuring range:

- **Linear range:** Signal level increases linearly from the detection limit 0.01 mg/m³ to several hundred mg/m³.
- **Nonlinear range:** From linear range up to several g/m³.
- **Saturation:** After non-linear range. The signal level reaches saturation and no longer increases.

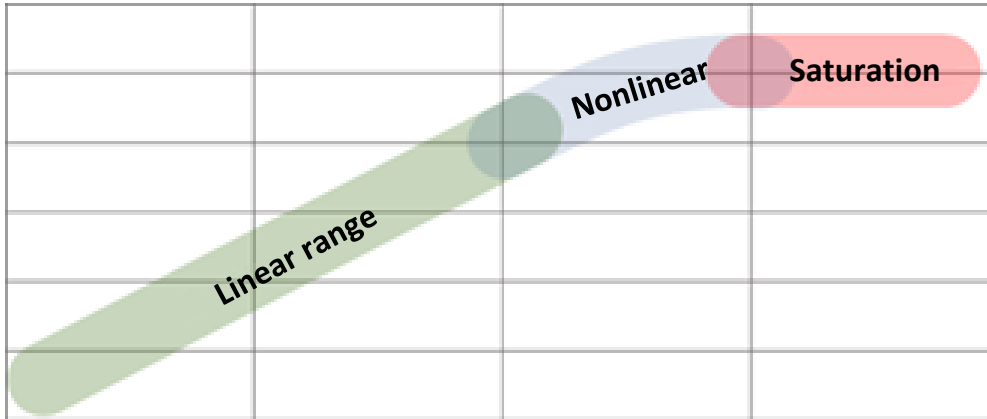

Figure 12: Uncalibrated measuring behavior

Many factors can affect the measuring range and behavior of the device. These factors include dust material, particle size, flow velocity and installation environment.



If it is necessary to measure concentrations that are higher than 200 mg/m³ and having linear behavior is critical, it is recommended to perform reference measurement at the desired concentration and to add additional calibration points using DustTool software.

Probe length

The recommended minimum probe length depends on the measuring conditions and environment. For example, in vertical ducts, the dust particles will concentrate in the middle of the duct with high flow velocity. In horizontal ducts, large particles will concentrate on the lower part of the duct with low flow velocity.

If the probe is too short compared to the duct diameter, the measurement results are inaccurate. The standard probe length is 500 mm (19.68 in).

Recommended probe lengths are:

- For indicative monitoring, a minimum probe length of one fourth ($\frac{1}{4}$) of the duct diameter is recommended.
- For demanding and critical applications with varying flow velocity, a minimum probe length of one third ($\frac{1}{3}$) of the duct diameter is recommended.



The sensor probe must not touch the opposite surface inside the duct, because it distorts the measurement results.

Particle material

Different materials can have different amounts of electrostatic charge. This means that the signals transmitted by dust particles can vary significantly from one material to another:

- Metals (inorganic, electroconductive) generate the lowest signals.
- Cement and minerals (inorganic, dielectric) generate average signals.
- Wood and flour (organic, dielectric) generate the highest signals.

As a result, different types of dust generate a different output signal at the same concentration.



Certain heavy metal dusts generate extremely low signals. For measuring such dusts, the device must be tested with a dust sample before delivery.

Common dust particle materials include:

- Grains
- Sugar
- Coal
- Cosmetics
- Dyes
- Ceramics
- Textiles
- Wood and paper
- Soap
- Metals and metal oxides
- Minerals
- Ores
- Cement
- Plastics
- Chemicals

Particle size

The minimum particle size that the device can detect is 0.3 μm . The optimal detection range is from 1 to 200 μm .

Relative humidity

The device is intended for use in non-condensing environments in both indoor and outdoor applications.

The relative humidity (RH) has an insignificant effect on the measurement results. However, the sensor does not distinguish liquid droplets from dust particles. This means that the measured airflow must not contain condensation. If the measured airflow contains condensed liquid droplets, it is possible that the device does not produce output signal at all, or the output signal can be too high.

Ambient temperature

Ambient temperature only has a very minor effect on the output signal.

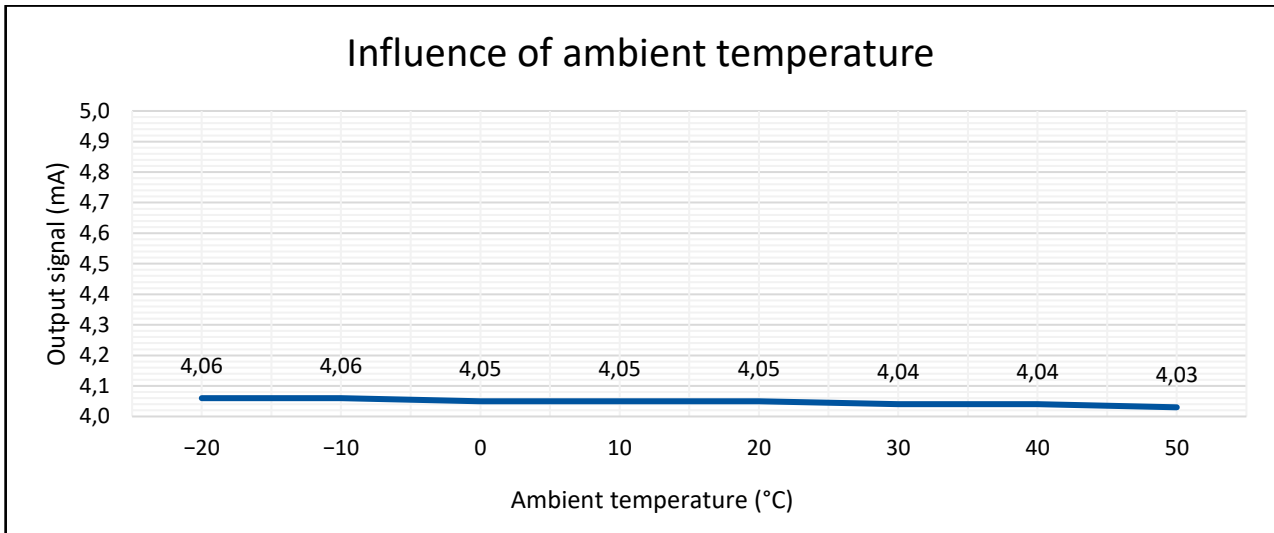

Figure 13: Influence of ambient temperature on the output signal

Flow velocity



Recommended minimum flow velocity is 3 m/s (9.84 ft/s).

Maximum tested flow velocity is 40 m/s (131.23 ft/s).

An increase in flow velocity also increases the output signal level. Dust material, particle size, temperature and installation environment can all affect output signal level.

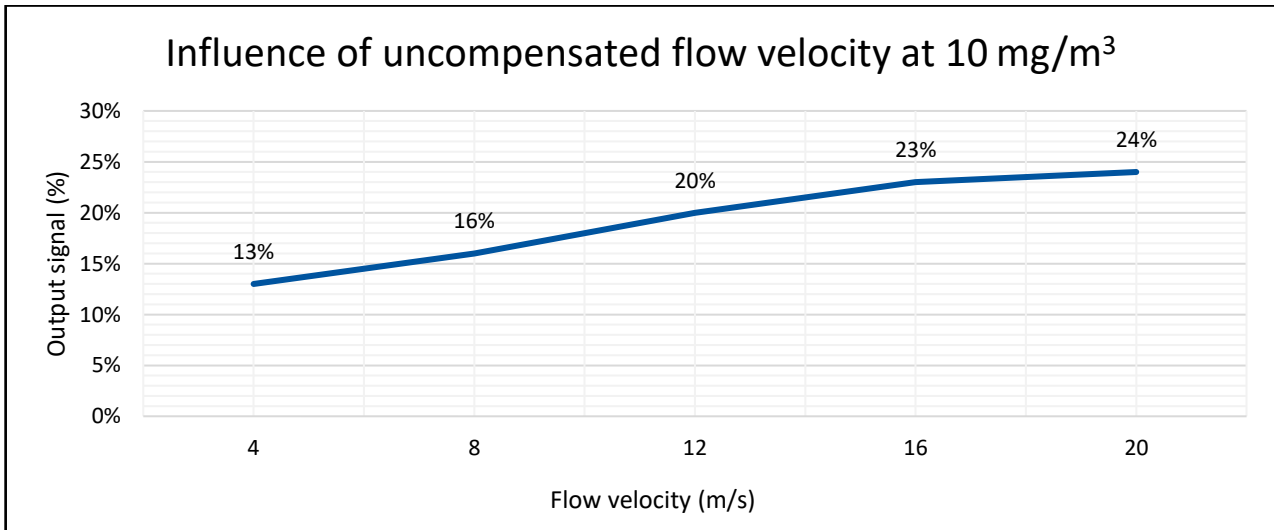

Figure 14: Influence of uncompensated flow velocity on the output signal

Model S304 has an option to compensate the changes in flow velocity by connecting the mA output of an external flowmeter to the analog mA input on the main board of the device. Figure 15 illustrates how compensating with an external flowmeter affects the measurement results. The data used for flow velocity compensation has been gathered over various laboratory tests.

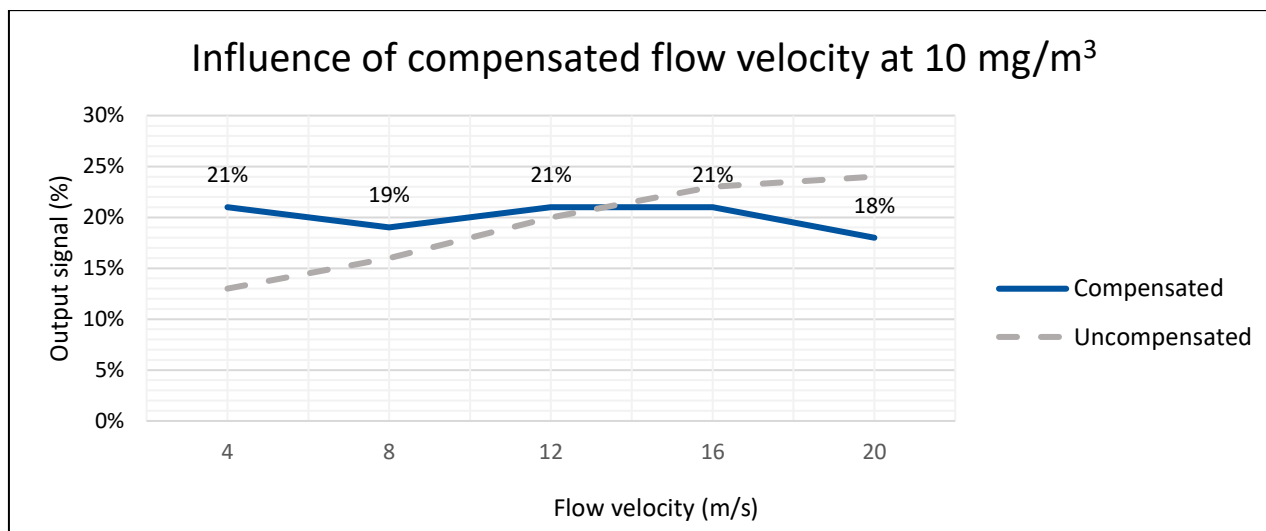

Figure 15: Influence of compensated flow velocity on the output signal

For information on how to connect an external flowmeter to model S304, see section



Analog mA input in chapter [Electrical connections](#).

For information on how to set the flow velocity compensation with parameters 7 and 8, see chapter [Parameters](#).

4 Storage

NOTICE

Improper storage can damage the equipment.

When storing the device:

- Select a dry, dust-free location.
- Store the device in its original packaging.
- Do not place any heavy objects on the device.
- Storage temperature must be within range $-40 \dots 60 \text{ }^{\circ}\text{C}$ ($-40 \dots 140 \text{ }^{\circ}\text{F}$).

Retain the original packaging in case the device is ever transported or returned. For instructions on how to return a damaged or defective device for repair or replacement, see section **Returns** in chapter **Maintenance and inspection**.

5 Mechanical installation



Read chapter “Safety” carefully before installing the device.

5.1 Unpacking and inspection

5.1.1 Unpacking

NOTICE

Improper handling during unpacking can damage the equipment.

When unpacking the device:

- If you use a knife or scissors to open the package, be careful not to damage the device or its parts.
- Handle the device and its components with care when taking them out of the package.
- Do not drop the device or subject it to blows.

5.1.2 Inspection

After unpacking the device:

- Check that the device and all its standard and optional parts are included in the delivery.
- Inspect the device and its individual parts for any defects, or damage that may have occurred during delivery.

For instructions on how to return a damaged or defective device for repair or replacement, see section **Returns** in chapter **Maintenance and inspection**.

5.2 Selecting installation location



Any information given in this user manual regarding the installation location or suitability for a specific application does not replace careful functionality checks and necessary approvals from an industry specialist.



Do not install the device close to large motors, cables carrying high voltages, or other potential sources of interference. These can distort the measurement results.

5.2.1 Ambient environment

NOTICE

If there are any structures that radiate heat near the device, you must insulate the heat source. Very high temperatures will damage the device.

To minimize the effect that the environment has on the measurement results, install the device in a suitable location. Table 3 shows the suitable ambient conditions for the device.

Table 3: Ambient conditions of the installation location

Ambient temperature:	-40 ... 60 °C (-40 ... 140 °F)
Relative humidity:	Max. 95 % RH (non-condensing)



The device is intended for use in non-condensing environments. The sensor does not distinguish liquid droplets from dust particles. If the measured airflow contains liquid droplets, the measurement results are inaccurate.

If the device is installed on the side of the duct in a location with occasional condensation, it is recommended to install the sensor probe with a 5° downward tilt. This helps prevent liquid from accumulating on the insulation.

5.2.2 Vibration

Probe lengths of less than 1 meter are not affected by vibration. However, the device must be installed in a location where the vibration level is below 5 m/s².

5.2.3 Location

An optimal location for installation is in a section of pipe or duct where the dust particles are evenly distributed in the airflow, and the flow is as laminar as possible. This ensures that the sensor probe comes into contact with an amount of particles that represents the actual dust concentration in the airflow.

Install the device in a straight section of pipe or duct that has no bends, valves, dampers or other obstacles in its vicinity. The recommended minimum distance to any obstacle is 5× the duct diameter if the obstacle is located upstream from the device, and 3× the duct diameter if the obstacle is located downstream from the device.

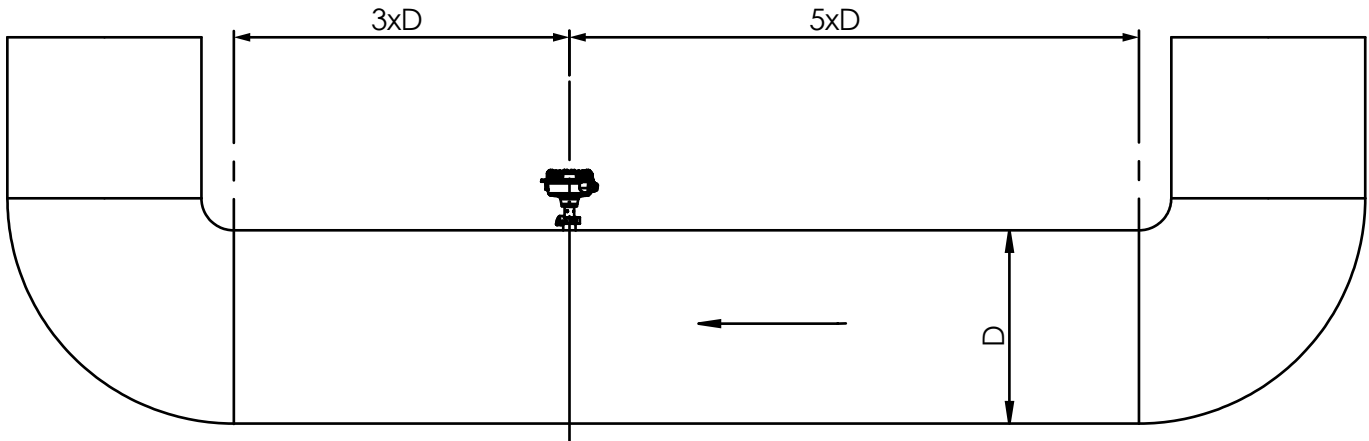

Figure 16: Recommended distance to obstacles (D = Duct diameter)

If the device is installed downstream from an electrostatic precipitator (ESP), the distance to ESP must be at least 40 m (131.23 ft). An ESP creates an electric field that can distort the measurement results.



If installing the sensor in a suboptimal location cannot be avoided, make sure that the location meets most of the requirements. Installation location must always meet these recommendations as closely as possible.

5.2.4 Orientation

The device must be installed perpendicular to the airflow, so that dust particles pass the sensor probe at a 90° angle.



If the device is installed on the side of the duct in a location with occasional condensation, it is recommended to install the sensor rod with 5° downward tilt. This helps prevent liquid from accumulating on the device insulation.

RF communication

If multiple devices are connected using a wireless RF connection, make sure that the devices are oriented the same way with RF antennas pointing in the same direction. This helps prevent polarization losses in the wireless communication.

5.2.5 Probe length

In vertical ducts, the dust particles will concentrate in the middle of the duct with high flow velocity. In horizontal ducts, large particles will concentrate on the lower part of the duct with low flow velocity. This means that the probe length must be suitable for the installation location.

If the probe is too short compared to the duct diameter, the measurement results are inaccurate. The standard probe length is 500 mm.

Recommended probe lengths are:

- For indicative monitoring, a minimum probe length of one fourth ($\frac{1}{4}$) of the duct diameter is recommended.

- For demanding and critical applications with varying flow velocity, a minimum probe length of one third ($\frac{1}{3}$) of the duct diameter is recommended.



The sensor probe must not touch the opposite surface inside the duct, because it distorts the measurement results.

5.2.6 Position



Information in this section mostly applies to horizontal pipes and ducts. On vertical pipes and ducts, the requirements for the installation position are not as strict. However, never install the device on a corner of a pipe or duct.

Square ducts

When installing on a square duct, the device can be placed either on the top of the duct, or to the side:

- When installing on the top, the device must be positioned in the middle of the duct.
- When installing on the side, the device must be positioned in the middle, or in the lower part of the duct. Recommended position is between $\frac{1}{2}$ and $\frac{2}{3}$ of the duct height measured from the top.

Permitted installation locations on square ducts are highlighted in green in Figure 17.

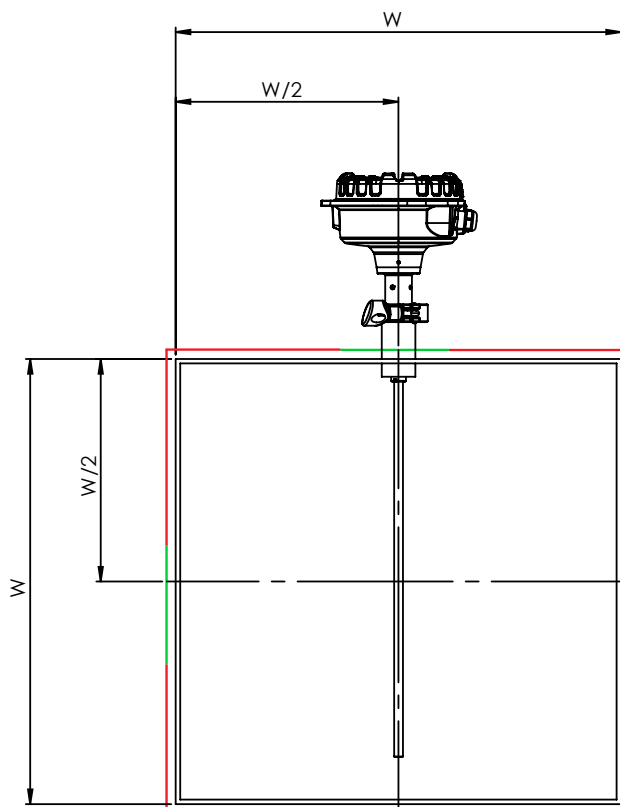

Figure 17: Approved installation positions on a square duct (W = Duct width)

You can always install the device on top of the duct if the installation location is within the specified ambient temperature range (-40 ... 60 °C [-40 ... 140 °F]). However, if there is significant heat transfer from the process, the device must be installed on the side of the duct.

The device must not be installed on the bottom or corners of the duct. Installing on the bottom or corners can result in inaccurate measurement results.

Round ducts

When installing on a round duct, the device can be positioned anywhere on the top half of the duct, between 9 o'clock and 3 o'clock positions. Permitted installation locations on round ducts are highlighted in green in Figure 18:

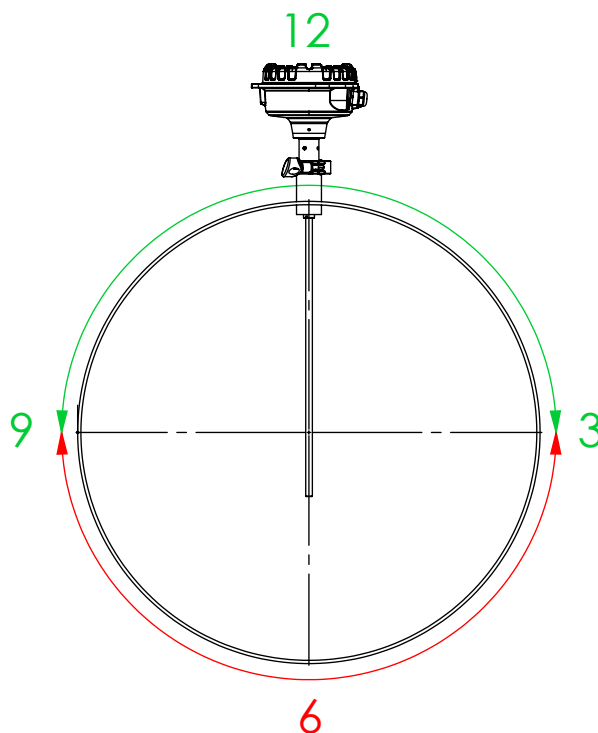

Figure 18: Approved installation positions on a round duct

You can always install the device on top of the duct if the installation location is within the specified ambient temperature range (-40 ... 60 °C [-40 ... 140 °F]). However, if there is significant heat transfer from the process, the device must be installed on the side of the duct.

The device must not be installed on the bottom half of the duct. Installing on the bottom can result in inaccurate measurement results.

5.2.7 Duct pressure

If possible, install the device in a location where the duct pressure is lower than the surrounding environment. This prevents the process gases from being released or minimizes the amount of gas that is released from the duct during installation.

If the duct pressure is higher than the surrounding environment, there is a risk that process gases are released from the duct.

5.2.8 Process temperature

NOTICE

If the device must be installed on a pipe or duct carrying hot gas, you must use a high-temperature process connection. High temperatures will damage the device and the probe insulation.

5.3 Installing sensor

5.3.1 Safety precautions



DANGER!

Poisonous and hot gas hazard

When installing or removing the device, poisonous and hot gas can be released from the duct.



Wear appropriate respiratory and eye protection gear when installing or removing the device. Follow all applicable local and plant-specific safety codes before proceeding.



WARNING!

Risk of burns due to hot components

When installing or removing equipment, the device or the installation surface can be hot.



Wear appropriate heat-resistant gloves and follow all applicable local and plant-specific safety codes before proceeding.

WARNING!



Risk of losing eyesight

Risk of burns

Welding arcs and flames emit intense heat and light that will damage eyesight and burn unprotected skin.

When welding, wear a welding mask and appropriate heat resistant gloves and clothing.



5.3.2 Installation

For mechanical installation, you need:

- A tool that is suitable for making an opening to the duct or pipe
- Welding equipment
- Protective gear for welding

To install the device:

1. Determine if the process that the device is installed on must be shut down before installation.
 - If the duct pressure is lower than the surrounding environment and the process does not produce any hot or dangerous gases, you can leave the process running.
 - If the duct pressure is higher than the surrounding environment and the process produces hot or dangerous gases, consider shutting the process down before installation.



It is the responsibility of the plant operator to decide whether a process can be running when the device is installed. Always follow the local and plant-specific safety standards when installing the device.

2. Make sure that the process connection is not attached to the device.

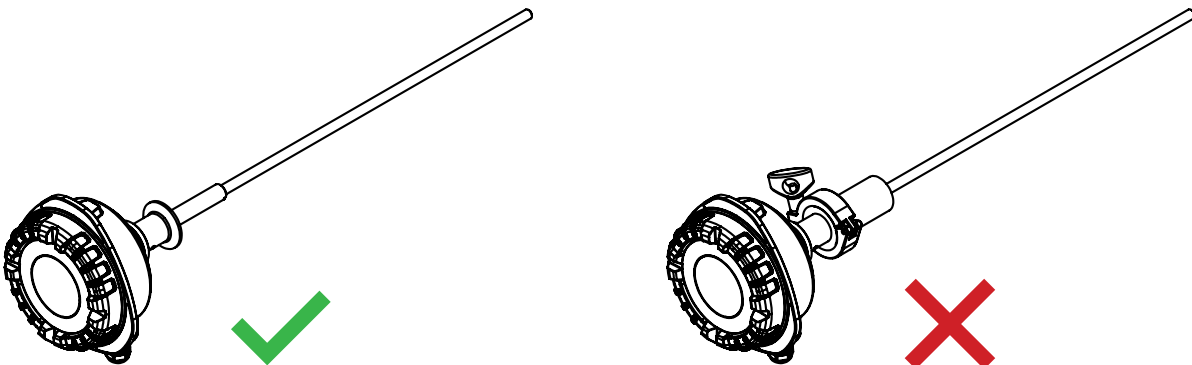

NOTICE

Do not install the process connection with the device fully assembled. If you weld the process connection in place with the device attached, you can damage the sensor.

3. Cut an opening to the duct or pipe.

Diameter of the opening depends on the shape and radius of the installation surface.

- If the installation surface is even or it has a large radius:
Cut an opening that is 36 mm (1.42 in) in diameter. This is slightly smaller than the outside diameter (OD) of the process connection (37.70 mm [1.48 in]) but larger than its inside diameter (ID) (34 mm [1.33 in]).
- If the installation surface is curved or uneven or it has a small radius:
Cut an opening that is 39 mm (1.54 in) in diameter. This is slightly larger than the outside diameter (OD) of the process connection (37.70 mm [1.48 in]).

4. Place the process connection over the opening or insert it slightly through the opening, depending on its diameter.

- If the diameter of the opening is smaller than the OD of the process connection, place the process connection on the installation surface, over the opening.

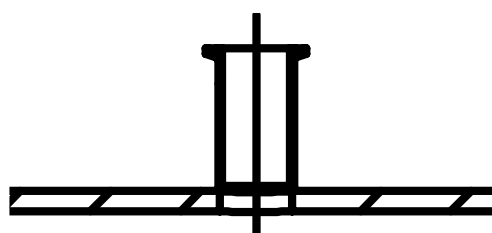

- If the diameter of the opening is larger than the OD of the process connection, insert the process connection slightly through the opening.

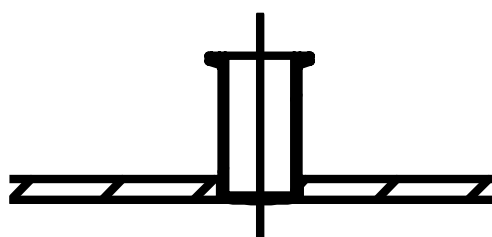

Do not push the process connection all the way through the opening.

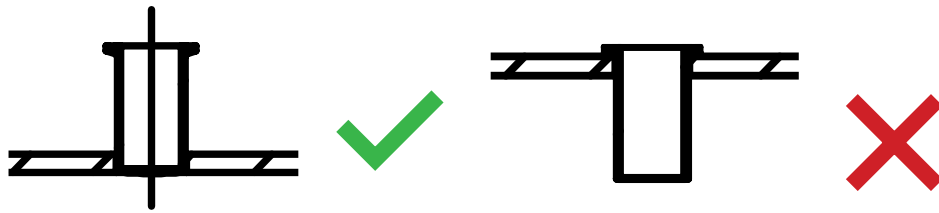

5. Make sure that the process connection is in the right position and correctly aligned. The socket must be perpendicular to the airflow inside the duct.

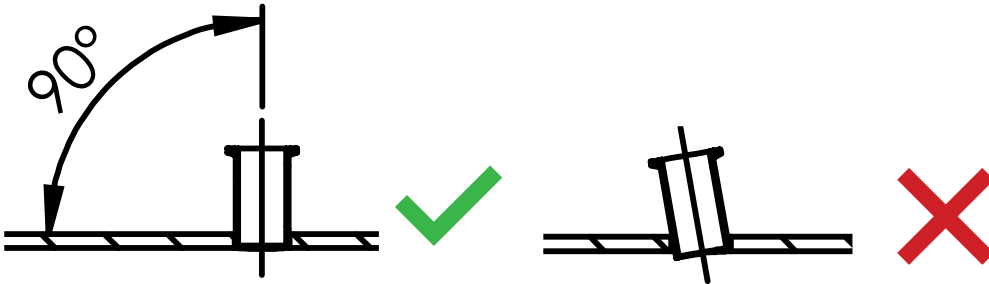

6. Weld the process connection to the duct or pipe. Make sure that the welding joint is airtight

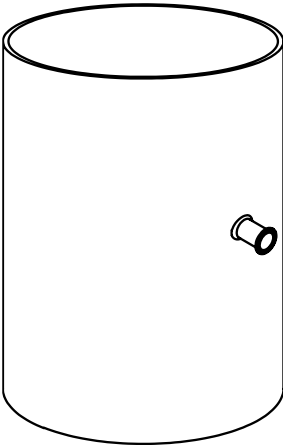

7. Fit the quick-clamp gasket on the sensor end of the process connection.

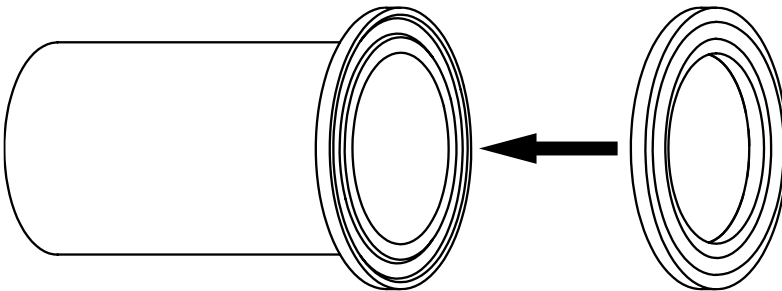

8. Insert the sensor probe through the process connection.

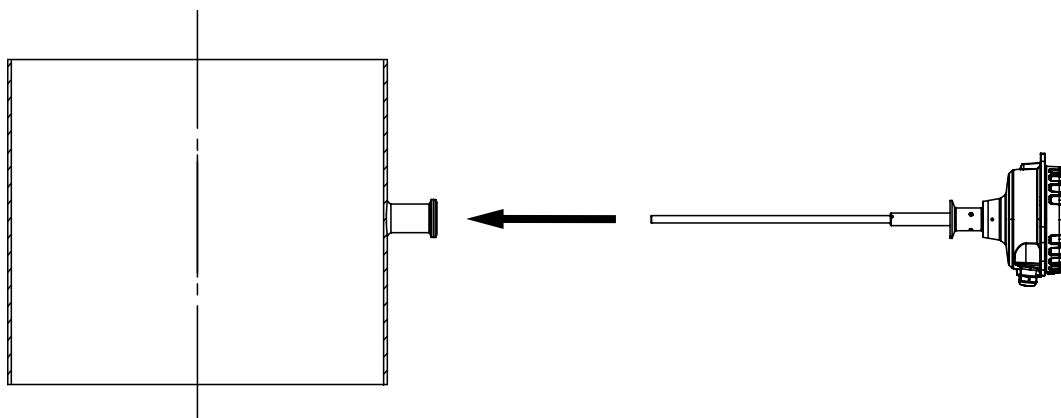

The sensor probe must not touch the opposite surface inside the duct, because it distorts the measurement results.

9. Secure the sensor in place with the quick-clamp connector.

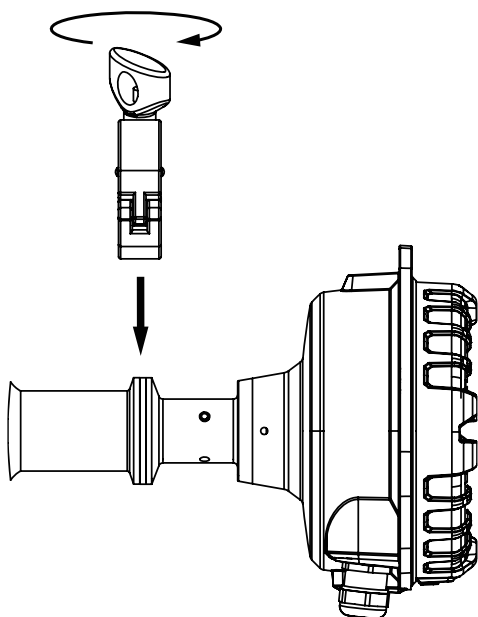

Note about Teflon-coated probes

A Teflon-coated probe consists of two parts. It has a translucent, outer Teflon sleeve and an inner black Teflon layer. The inner layer is the actual insulating coating of the probe, and the outer sleeve protects the coating from scratches and dirt.

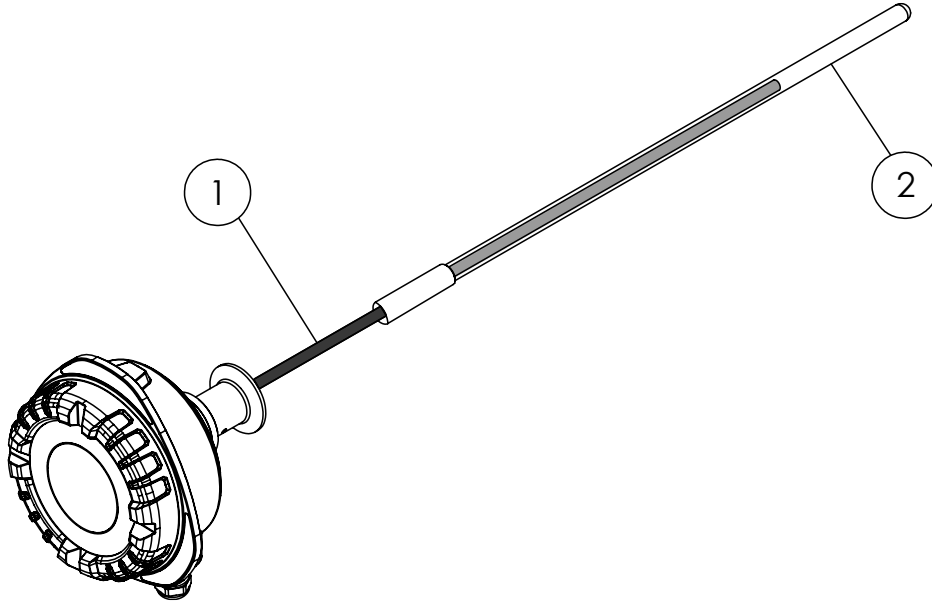

Figure 19: Parts of Teflon-coated probe

- | | |
|---|--|
| ① | Inner insulating Teflon layer |
| ② | Outer translucent protective Teflon sleeve |

NOTICE

If your device is equipped with a Teflon-coated probe, do not remove the outer Teflon sleeve during installation. The outer sleeve is an integral part of the probe and must always be kept on to ensure proper operation.

6 Electrical installation



Read chapter “Safety” carefully before making any electrical connections to the device.

6.1 Electrical safety



Wear protective glasses when making electrical connections on the device.

WARNING!



Electric shock hazard

Faulty electrical installations, too high line voltage or incorrect operation of the device can result in an electric shock. Only trained and qualified personnel can install, commission, operate and perform maintenance on the device.

To ensure safe installation of electrical connections:

- Power down the device when you are making electrical connections, when you intend to perform maintenance on it, or in the event of malfunction.
- Connect the device to line voltage only if the power supply specifications correspond to the data on the identification label of the device.
- Make sure that all equipment is properly grounded.
- Stand on an insulating pad and check components only with one hand.
- Never work alone on electrical connections.

When connecting cables, give them enough extra length. This allows the device to be removed from the mechanical installation for inspection and maintenance without disconnecting the cables.



Cables must be installed in accordance with all applicable local safety codes.

6.2 Cable types



Make sure that the cables are suitable for the environment and industrial application where the device is used. The cables must meet and be installed according to all applicable local safety standards.

When choosing cables, consider the following:

- Use a shielded cable if possible. Connect the cable shield to ground on one end only.
- Minimum required conductor size is 0.3 mm² or 22 AWG.
- The cables must withstand up to 75 °C (167 °F) continuous temperature.

The device uses screw-type wire-to-board terminal blocks for electrical connections. See Table 4 in section **Terminal blocks** for specifications.

6.3 Electrical connections

6.3.1 Main board

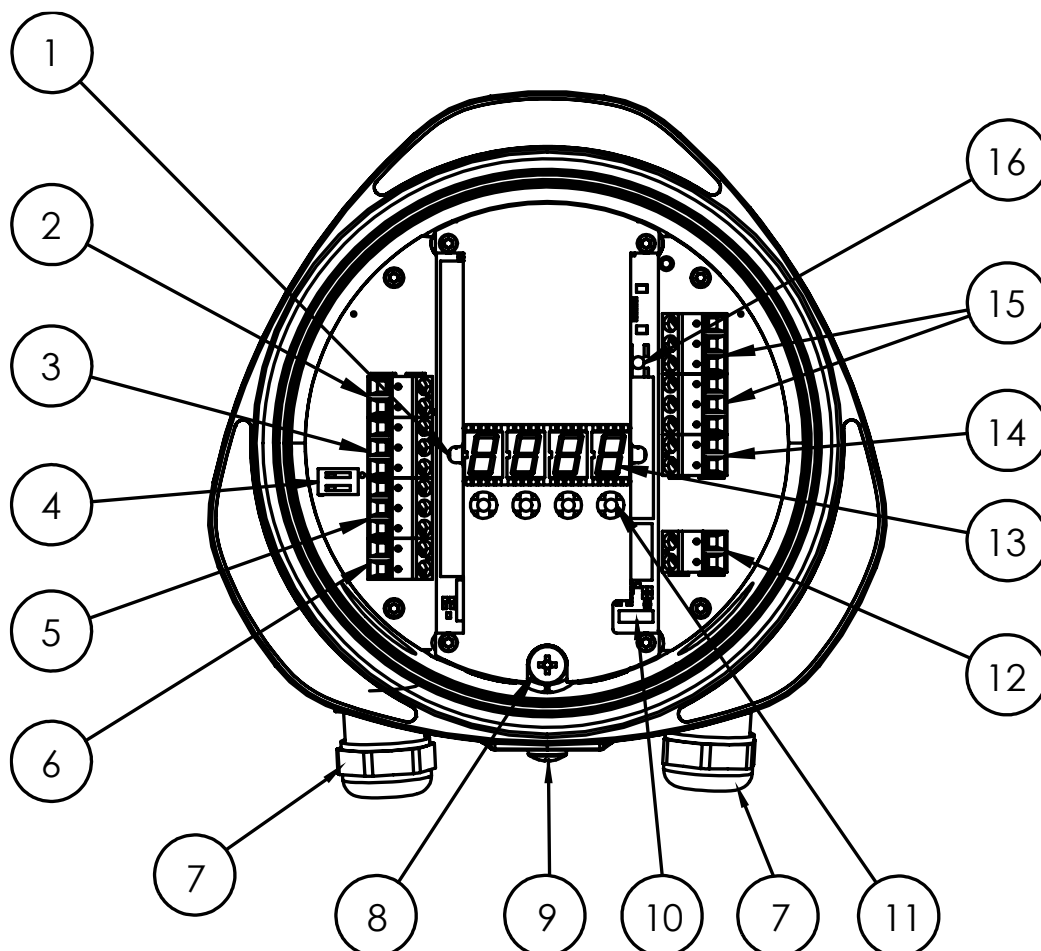

Figure 20: Main board and electrical connections of the dust monitor

① Status LED	⑨ External ground connection
② Analog mA output	⑩ Micro-B USB port
③ RS-485 bus (Modbus RTU)	⑪ Navigation keys
④ RS-485 terminator switch	⑫ 24 V DC power supply terminal
⑤ RS-485 bus (Sintrol Network)	⑬ 7-segment displays
⑥ Analog mA input*	⑭ 100 ... 240 V AC power supply terminal
⑦ PG11 cable glands	⑮ Relay terminals
⑧ Internal ground connection	⑯ Auto Setup key

* Only functional in model S304.

6.3.2 Terminal blocks

The device uses screw-type wire-to-board terminal blocks for electrical connections. See Table 4 for specifications:

Table 4: Specifications of the terminal blocks

Connection method:	M3 slotted screw		
Tightening torque:	0.5 ... 0.6 Nm (4.425 ... 5.310 in-lb)		
Insulation stripping length:	8 mm (0.31 in)		
Pitch:	5.08 mm (0.20 in)		
Connection angle:	55°		
Conductor size:	<u>Solid</u> 0.2 ... 4 mm ²	<u>Flexible</u> 0.2 ... 2.5 mm ²	<u>AWG</u> 24 ... 12



Terminal blocks are compatible with smaller conductor sizes than the minimum conductor size that is recommended for the device. Do not use a conductor size that is smaller than 0.3 mm² / 22 AWG to make electrical connections on the device.

6.3.3 Grounding

WARNING!



Risk of injury

If the dust monitor is not grounded properly, it can display false measurement results. In the worst case, this can result in severe health impacts to workers, or even a failure of an explosion prevention system.

For proper and safe operation, it is critical that the device is properly connected to ground. The enclosure is equipped with two ground connections. One ground connection is located inside the enclosure, and one on the outside (Figure 21).

- If the ground potential between the power supply and the installation location is the same, connect the supply ground to the internal ground connection.
- If there is ground potential difference between the power supply and the installation location, ground the device to the local ductwork using the external ground connection. In this case it is also recommended to supply power to the device with a DC power supply.

WARNING!



Risk of malfunction

Different ground potentials between the power supply and installation location can create ground current loops, which can result in false measurement results. Depending on the application, this can have severe implications on worker health and safety. Always make sure that the device is grounded properly.

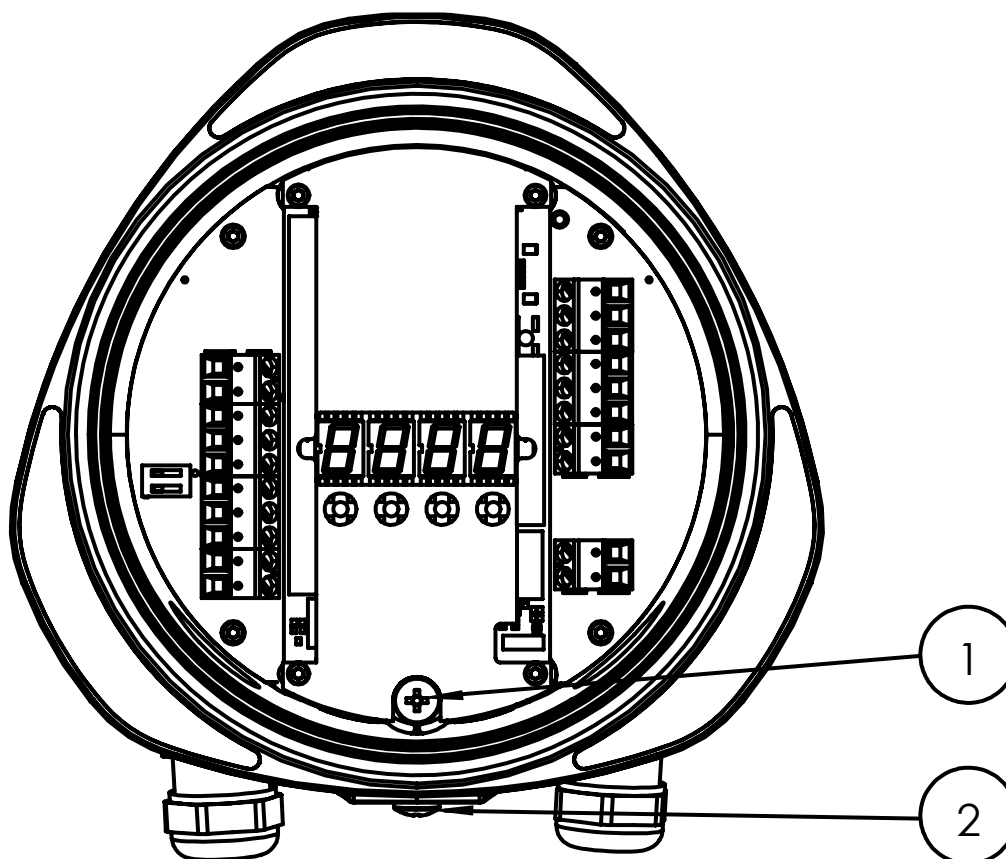

Figure 21: Position of ground connections on the enclosure

- ① Internal ground connection
- ② External ground connection

When the device is grounded properly, there is a clear change in the output signal level when you touch the probe. There must be no change in the output signal level when you touch the enclosure.

Signs of improper grounding

If the device is not grounded properly, it can show the following behavior:

- Base value of the output signal is >3000 IEU when the process is not running.
- The output signal level does not change significantly when you touch the probe.
- The output signal level changes when you touch the enclosure.
- The displays indicate “Err1” with the red status LEDs blinking. This means that the sensor probe is grounded.



Subpar power supply can cause behavior similar to improper grounding. Only use NEC Class 2 or equivalent power supply.

Connecting ground wire

To connect the device to ground, you need:

- Protective gear for electric work
- Phillips-head screwdriver (M5)
- Wrench (20 mm [0.7874 in] or adjustable)
- Suitable ground wire

To connect the device to ground:

1. Make sure that the device is not connected to the power supply, or that the power supply is disconnected or isolated.
2. Select the ground connection that you want to use for connecting the device to ground.
3. Connect the ground wire to the device.
 - Internal ground connection:
 - a. Remove the device lid by turning it counterclockwise to access the main board.

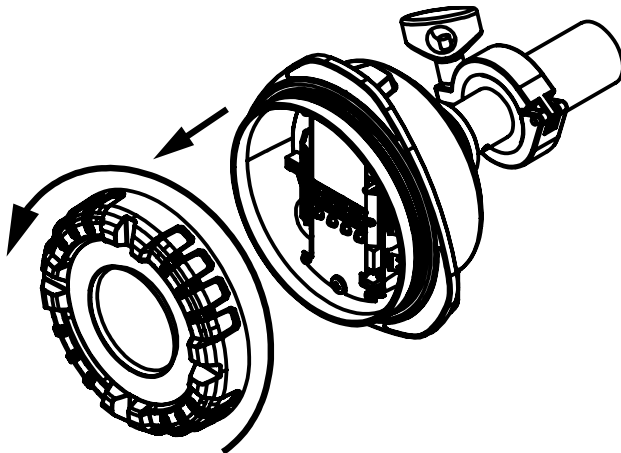

- b. Remove the cable gland at the cable entry that is located on the right side of the device when you are facing the main board. Loosen the cable gland cap by turning it counterclockwise with a wrench.

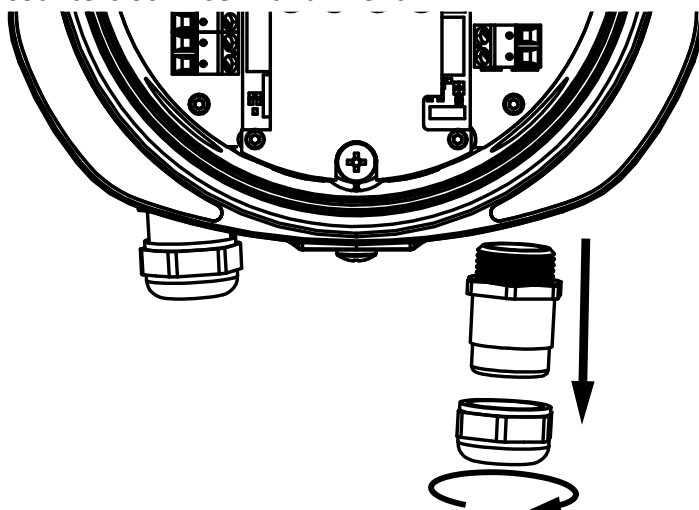

- c. Slide the cable gland over the incoming ground wire.

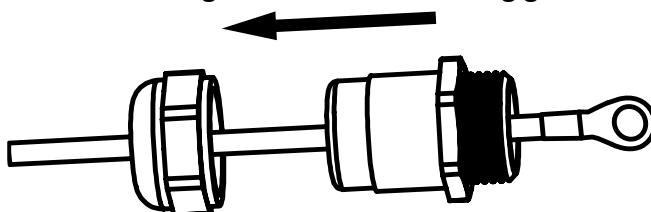

- d. Insert the ground wire through the cable entry.

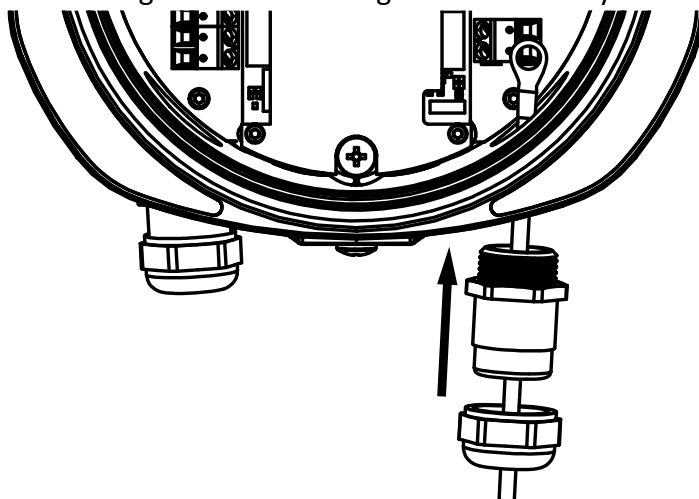

- e. Loosen the screw on the ground connection with a screwdriver.

- f. Place the ground wire under the screw head on the ground connection and tighten the screw.

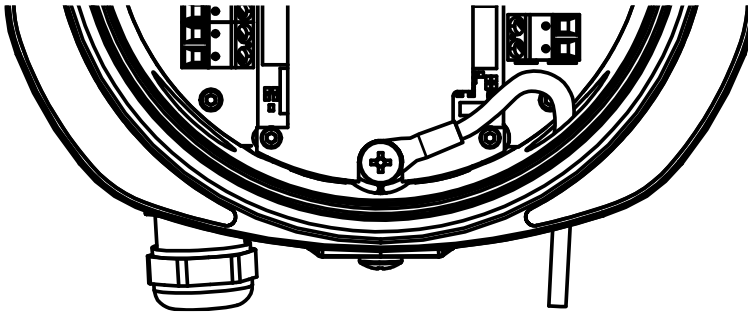

- g. If you do not need to make any other electrical connections:
- Push the cable gland back inside the cable entry and tighten the cap with a wrench.

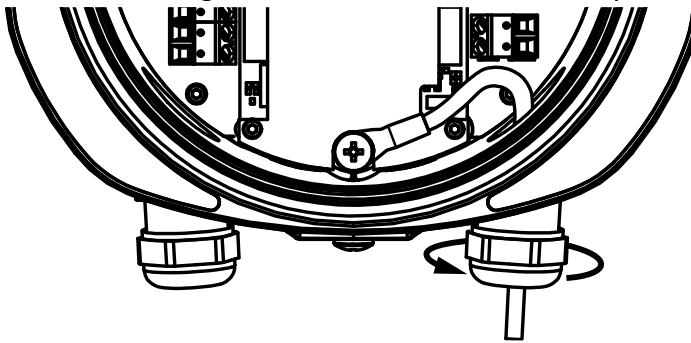

- Attach the device lid by tightening it clockwise.

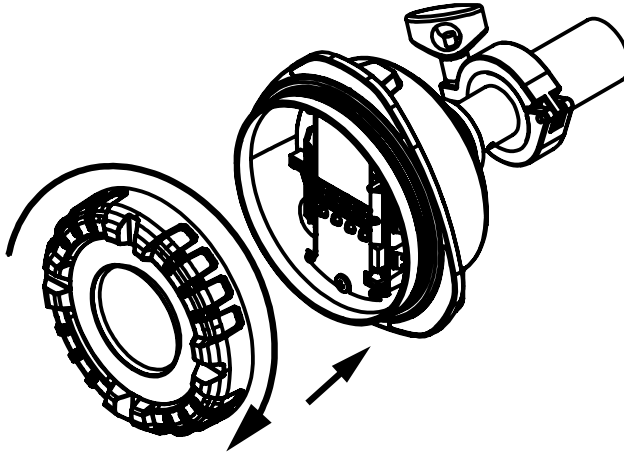

- External ground connection:
 - a. Loosen the screw on the ground connection with a screwdriver.
 - b. Place the ground wire under the screw head on the ground connection and tighten the screw.

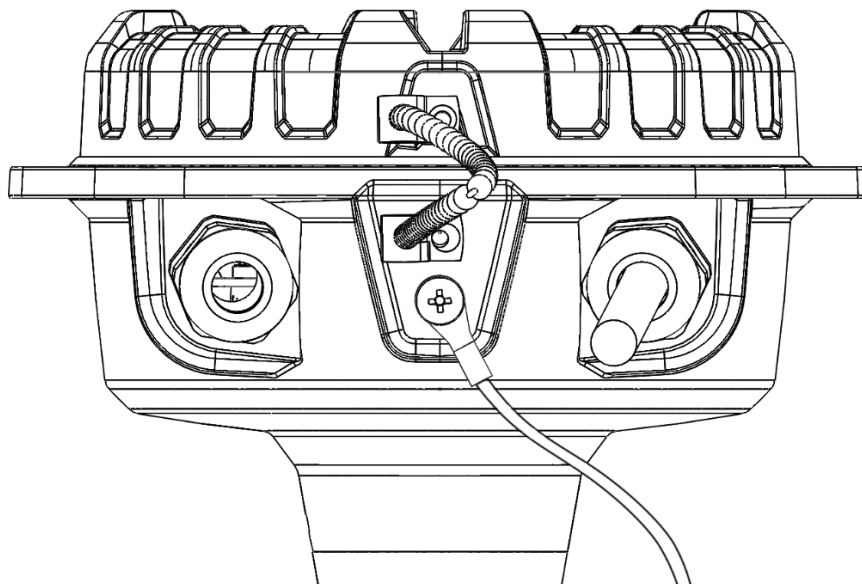

4. Connect the other end of the ground wire to a location with the same ground potential as the ductwork that the device is installed on.

6.3.4 Power supply

DANGER!



Electric shock hazard

Before connecting the device to a power supply, make sure that the power supply is isolated or disconnected. Electric shock from a connected power supply cable can result in serious injury or death.

When connecting the device to a power supply, wear protective glasses, protective clothing and insulating rubber gloves.



The device can be connected to either a 24 V DC or 100 ... 240 V AC power supply. Both power inputs are polarity-free. Only use NEC Class 2 or equivalent power supply.

- Protective gear for electric work
- Slotted-head screwdriver (M3)
- Wrench (20 mm [0.7874 in] or adjustable)
- Suitable power cable

To connect the device to power supply:

1. Make sure that the power supply is disconnected or isolated.
2. Remove the device lid by turning it counterclockwise to access the main board.

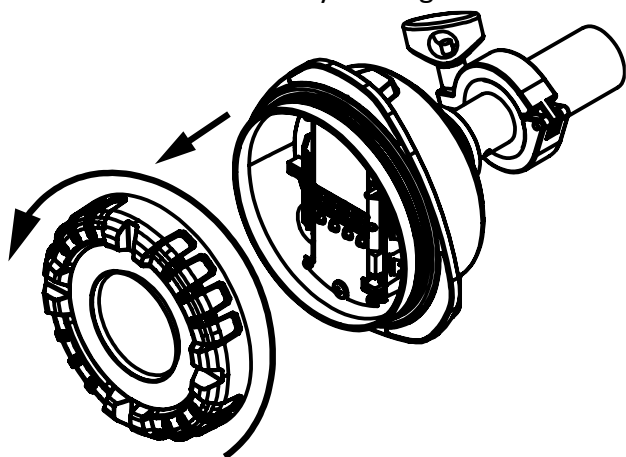

3. Remove the cable gland at the cable entry that is located on the right side of the device when you are facing the main board. Loosen the cable gland cap by turning it counterclockwise with a wrench.

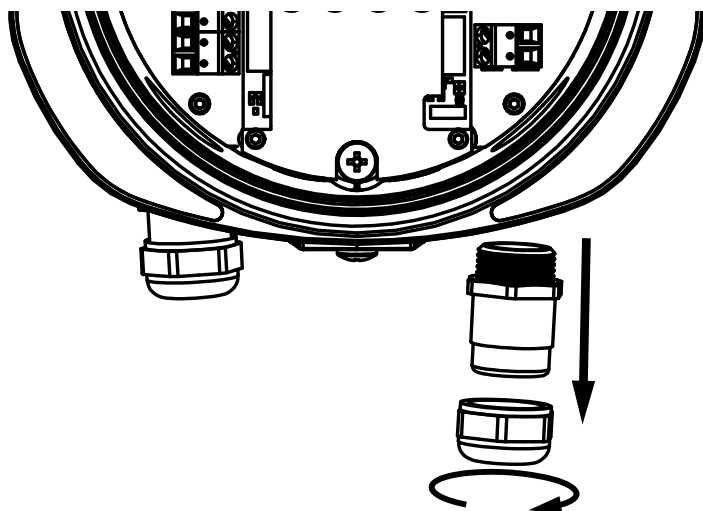

4. Slide the cable gland over the incoming power cable.

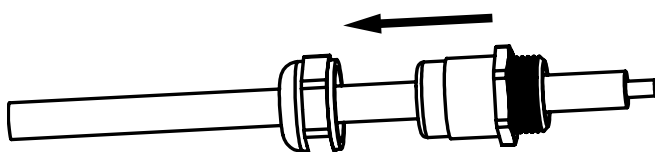

5. Insert the power cable through the cable entry.

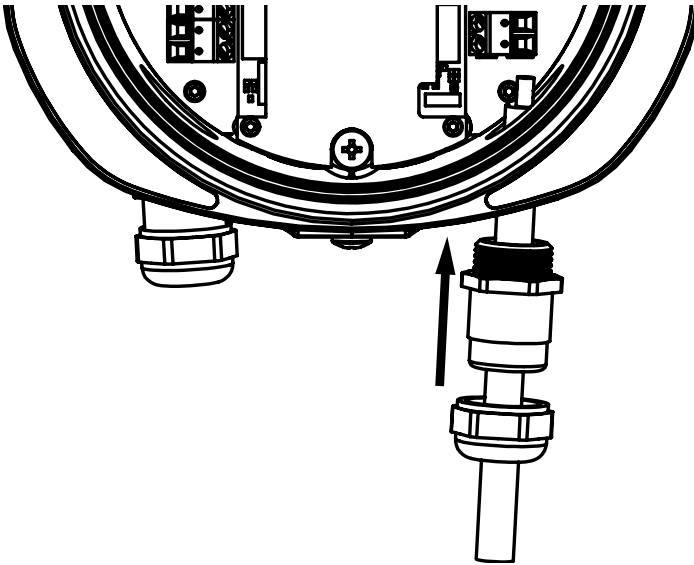

6. Connect the power cable to either the 24 V DC or 100 ... 240 V AC power supply terminal. Insert the wires to the terminal block and tighten the screws.

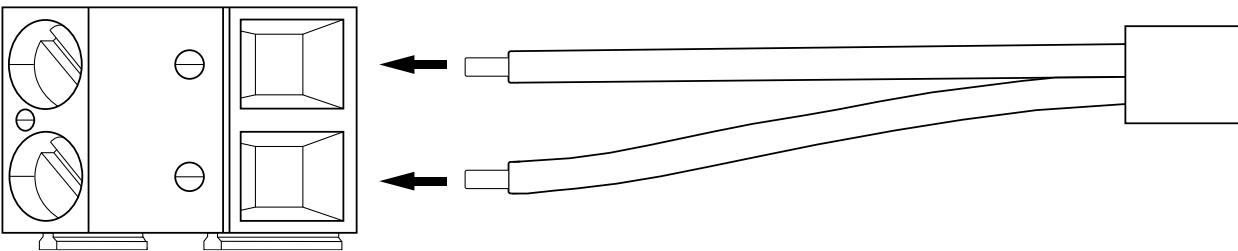

7. If you do not need to make any other electrical connections:

- Push the cable gland back inside the cable entry and tighten the cap with a wrench.

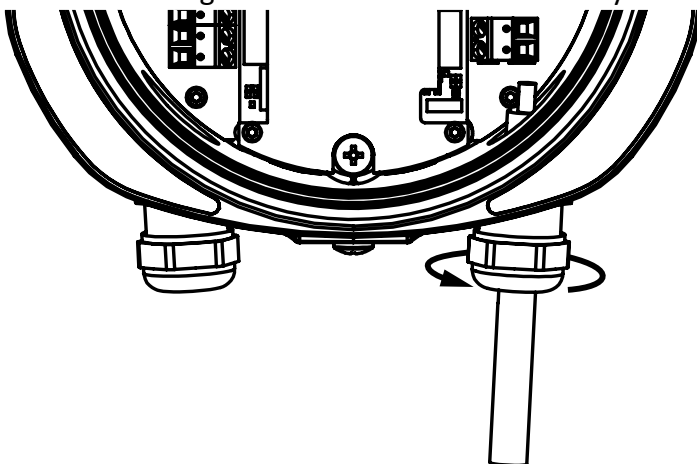

- Attach the device lid by tightening it clockwise.

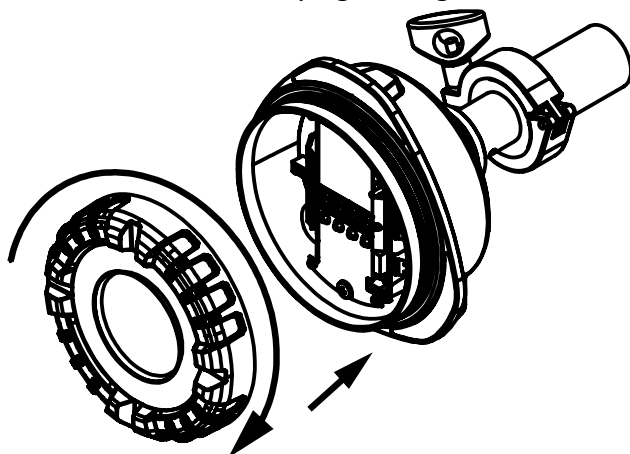

- Enable or connect the power supply, and power up the device.

6.3.5 Relays

The device has two Single Pole Double Throw (SPDT) relays. The contacts are labeled “A”, “B” and “C”, with C being the common contact. The relays can be used to control external loads of up to 240 V AC / 5 A or 30 V DC / 5 A.

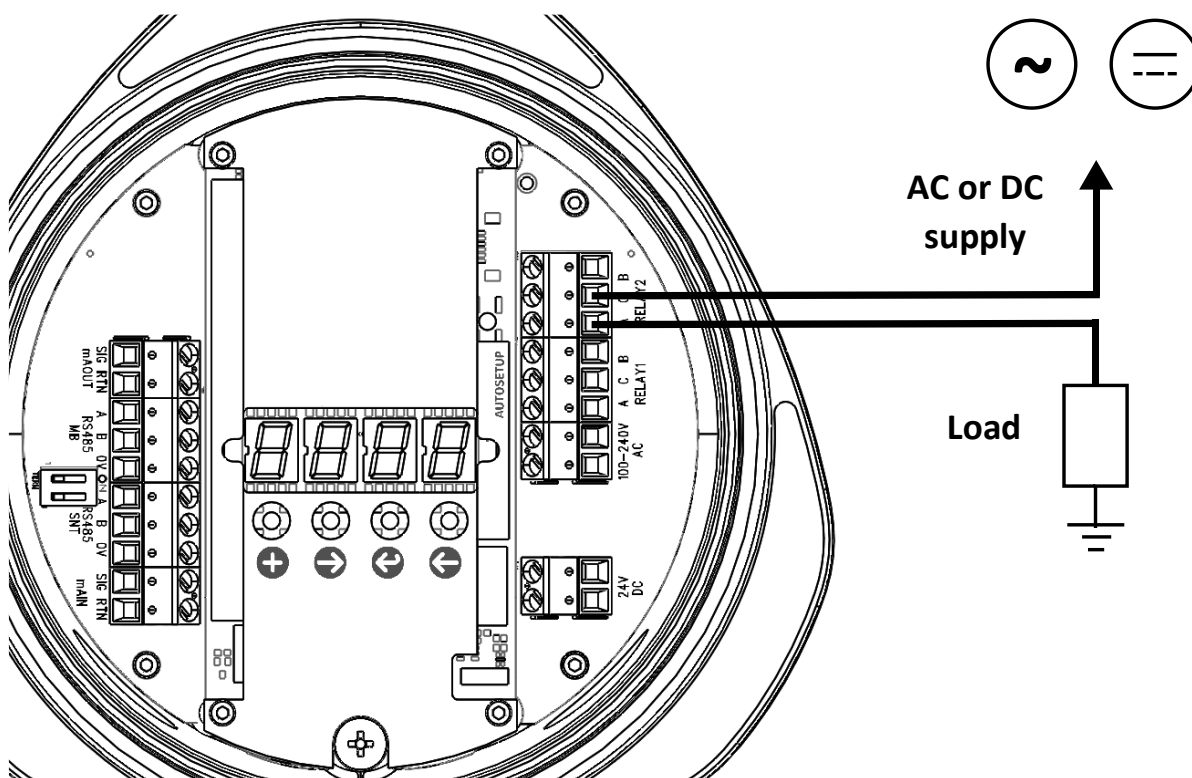

Figure 23: Relay connections on the main board



Connect the sheath of a shielded cable to ground on one end only. Connecting both ends to ground can create a ground loop.

To connect a relay, you need:

- Protective gear for electric work
- Slotted-head screwdriver (M3)
- Wrench (20 mm [0.7874 in] or adjustable)
- Two suitable 2-wire signal cables

To connect the relays:

1. Make sure that the device is not connected to the power supply, or that the power supply is disconnected or isolated.
2. Remove the device lid by turning it counterclockwise to access the main board.

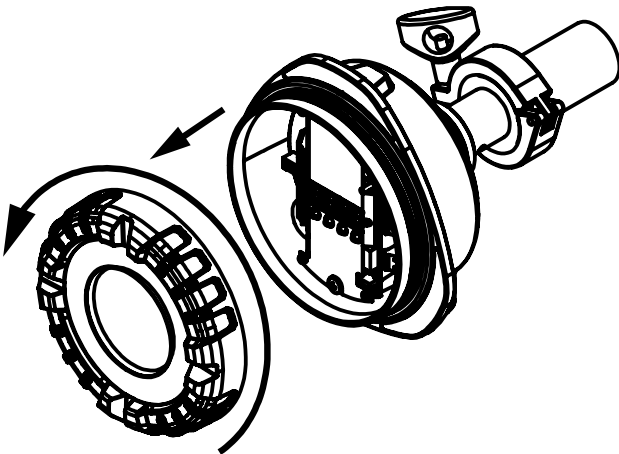

3. Remove the cable gland at the cable entry that is located on the right side of the device when you are facing the main board. Loosen the cable gland cap by turning it counterclockwise with a wrench.

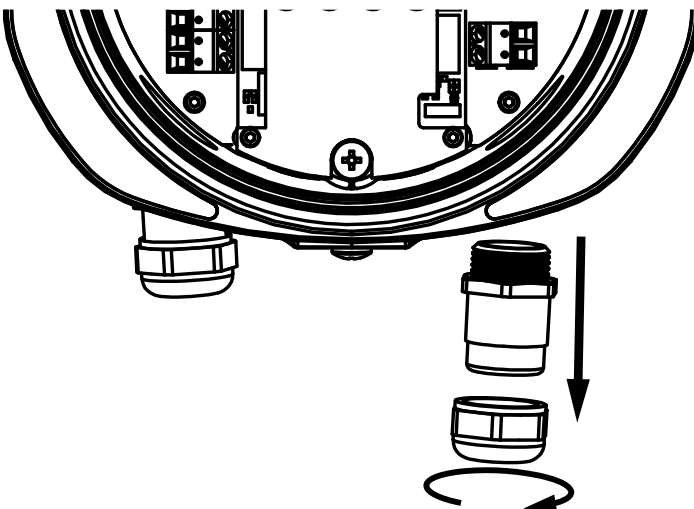

4. Slide the cable gland over both incoming signal cables.

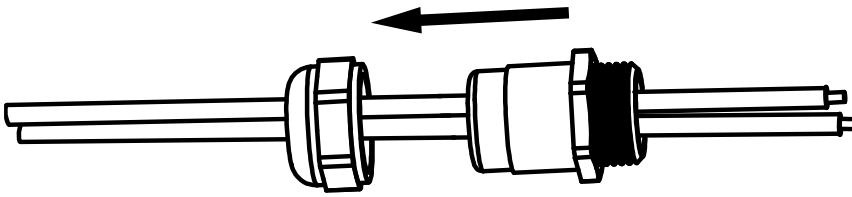

5. Insert both signal cables through the cable entry.

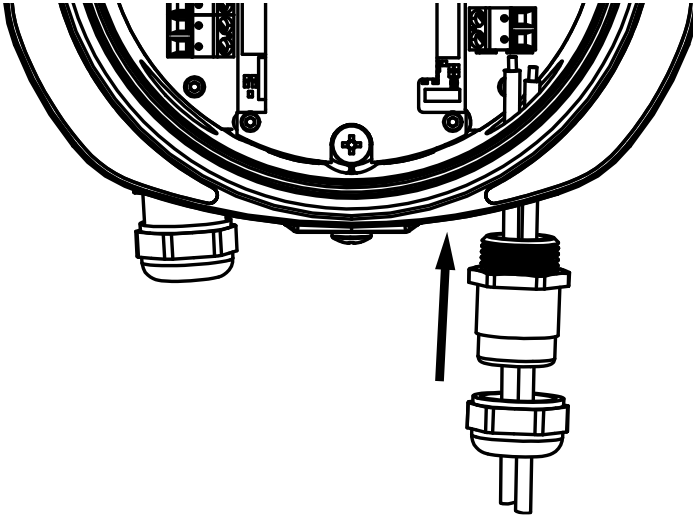

6. Connect the first signal cable to contact C and either contact A or B on RELAY1 output terminal block.
7. Connect the second signal cable to contact C and either contact A or B on RELAY2 output terminal block.
8. Connect the other end of each signal cable to the appropriate input terminal on the application that you want to control with the relays.
9. If you do not need to make any other electrical connections:
- Push the cable gland back inside the cable entry and tighten the cap with a wrench.

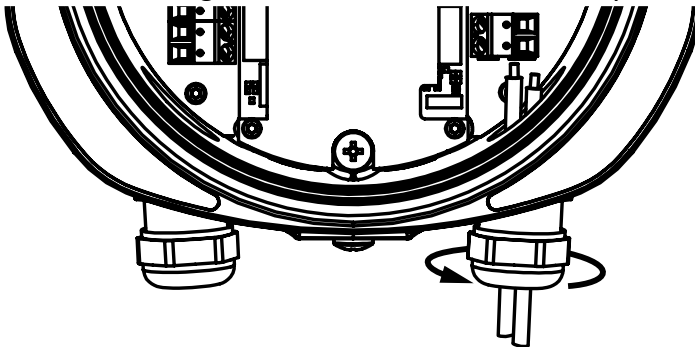

- Attach the device lid by tightening it clockwise.

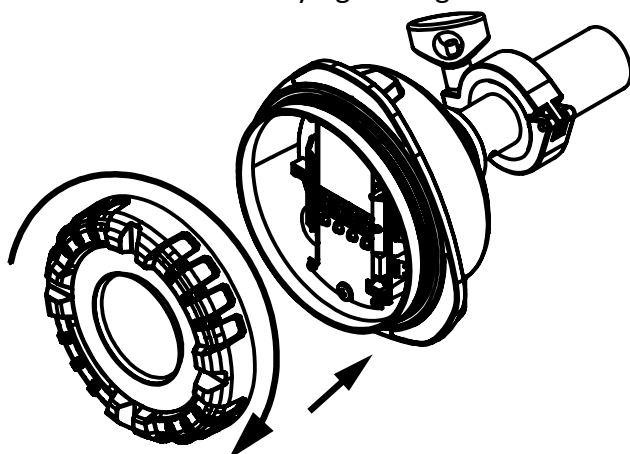

- Enable or connect the power supply, and power up the device.

When programming the external device to receive the signals from the relays, refer to Table 14 in section **Relay logic** in chapter **Operation**.

6.3.6 Analog mA output

The device has a single active and isolated mA output that uses industry standard 4 ... 20 mA signal range for indicating status and measurement value. Maximum resistance for the mA loop is 250 Ω . The mA output is intended to be used as a long-range analog data transfer in industrial applications.

After Auto Setup, the default output signal level is set to 5% of the scale (4.8 mA). This means that 20 mA output signal indicates a 20 \times increase in dust concentration. The scale of the mA output can also be customized according to the specific end-user application.

>22 mA signals are used to indicate sensor fault in accordance with NAMUR NE43.

Table 5: Measurement values corresponding to device status

mA output	Status
4 ... 20 mA	Normal operation or zero/span self-test
>22 mA	Device failure, for example due to improper grounding or failure of the internal checks of the device

Connecting mA output

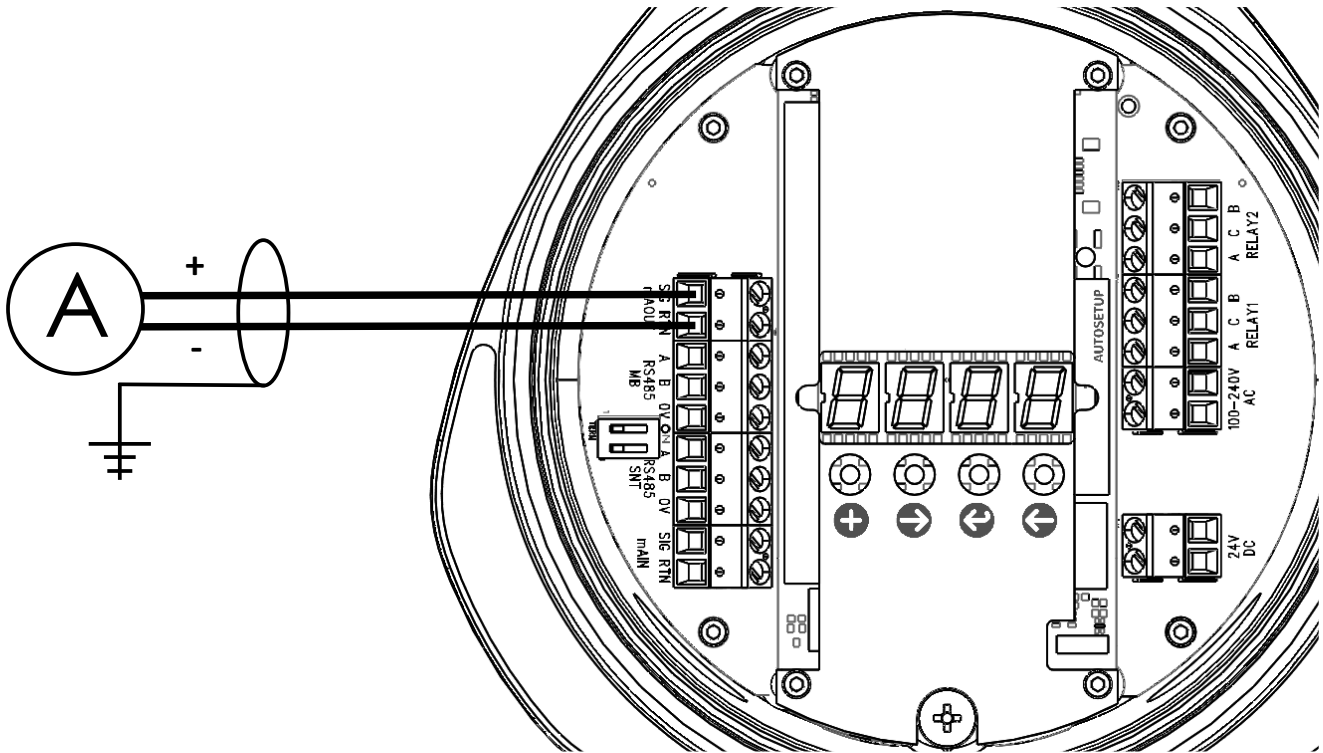

Figure 24: mA output on the main board

To connect the mA output, you need:

- Protective gear for electric work
- Slotted-head screwdriver (M3)
- Wrench (20 mm [0.7874 in] or adjustable)
- Suitable signal cable



Connect the sheath of a shielded cable to ground on one end only. Connecting both ends to ground can create a ground loop.

To connect the mA output of the device:

1. Make sure that the device is not connected to the power supply, or that the power supply is disconnected or isolated.

2. Remove the device lid by turning it counterclockwise to access the main board.

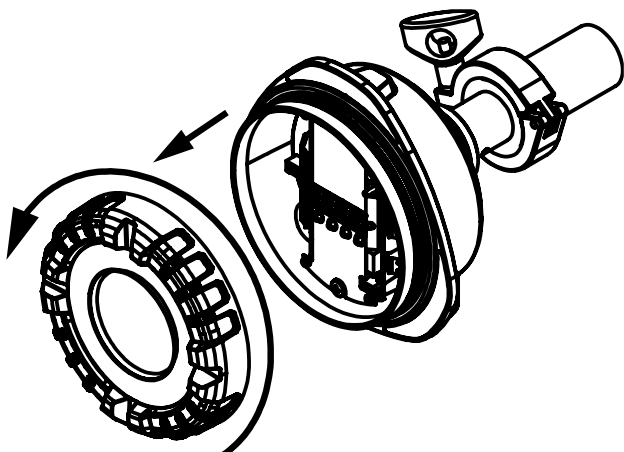

3. Remove the cable gland at the cable entry that is located on the left side of the device when you are facing the main board. Loosen the cable gland cap by turning it counterclockwise with a wrench.

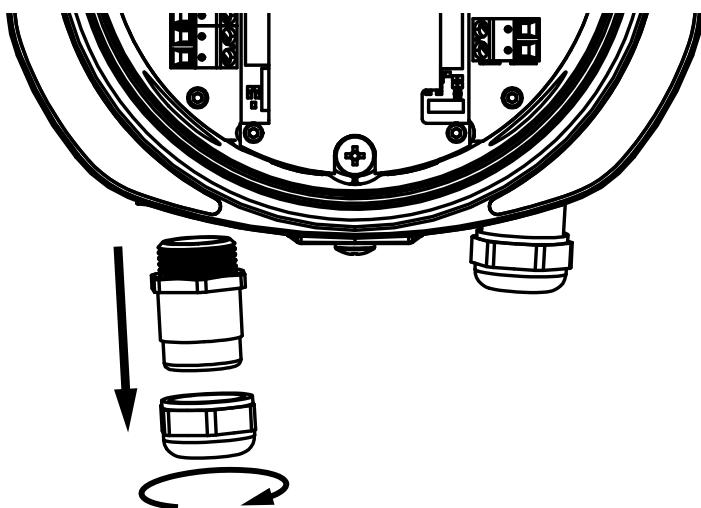

4. Slide the cable gland over the incoming signal cable.

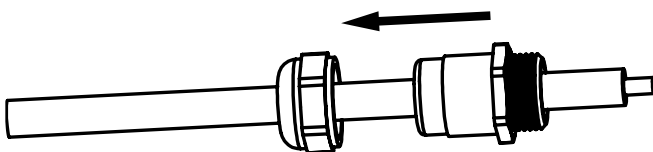

5. Insert the signal cable through the cable entry.

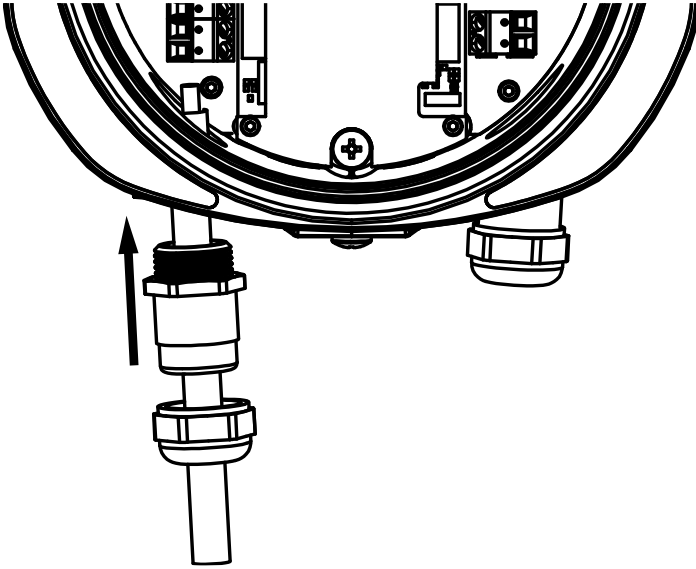

6. Connect the signal cable to mA output terminal block.
Insert the wires to the terminal block and tighten the screws.

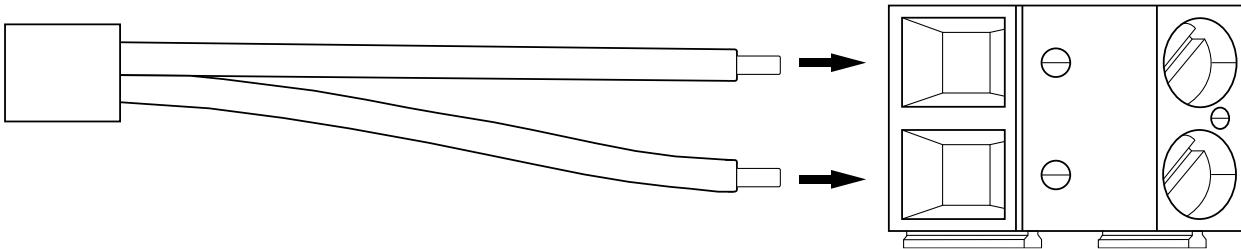

7. Connect the other end of the signal cable to the device that receives the mA output.
8. If you do not need to make any other electrical connections:
 - Push the cable gland back inside the cable entry and tighten the cap with a wrench.

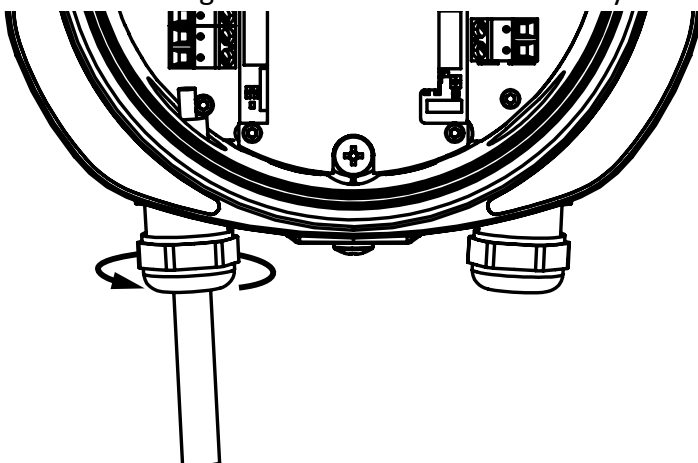

- Attach the device lid by tightening it clockwise.

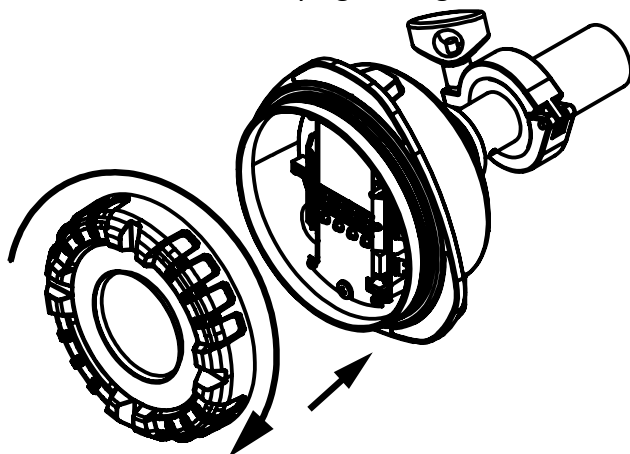

- Enable or connect the power supply, and power up the device.

6.3.7 RS-485 buses

The device has two isolated RS-485 buses. The buses can be used to integrate the device into existing automation systems, and to connect multiple devices in parallel to create a network. They can be used to read data from the device, and to change device parameters. Buses are labeled “MB” and “SNT”.

- MB bus is designed for connecting multiple devices into a single bus on a master device using either Modbus RTU or Sintrol Network protocol.
- SNT bus is designed for connecting a single device to a PC running a DustTool software.

The default communication parameters for Modbus RTU are as follows:

Table 6: Modbus RTU communication parameters

Baud rate:	19200
Data bits:	8
Stop bits:	1
Parity:	Even

For a quick reference of the register definitions of the Modbus RTU interface, see **Appendix B: Modbus RTU registers**.

For information about setting up device networks, see section **Setting up device network** in chapter **Commissioning and system setup**.

Polarity

Polarity of the RS-485 bus is indicated with labels A and B, where wire A is negative (-) and wire B is positive (+). Make sure to always connect wires A and B using correct polarity to the device that receives the signal.



Markings that indicate polarity on the RS-485-to-USB converter supplied by Sintrol are inverted. When using RS-485-to-USB converter supplied by Sintrol, connect wire A to + and wire B to -.

Some manufacturers have the RS-485 output signals inverted, and the way signal polarity is labeled can differ between manufacturers. For example, some manufacturers indicate negative polarity with TX-/RX- or D- instead of A, and positive polarity with TX+/RX+ or D+ instead of B.



If you are connecting the device into an existing Modbus RTU automation system or if you are using a third-party RS-485-to-USB converter or cable, read the related user documentation carefully before connecting the RS-485 output.

Connecting RS-485 bus

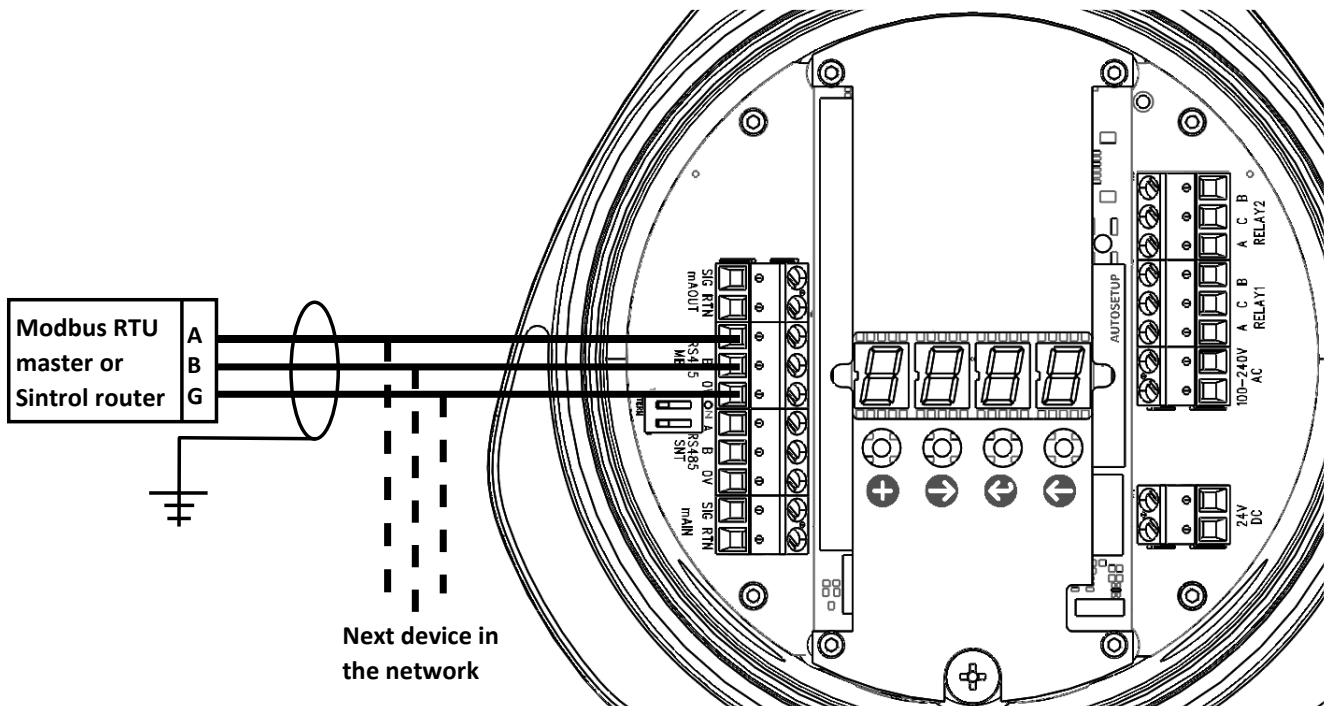

Figure 25: Modbus RTU bus on the main board



Connect the sheath of a shielded cable to ground only on one end. Connecting both ends to ground can create a ground loop.

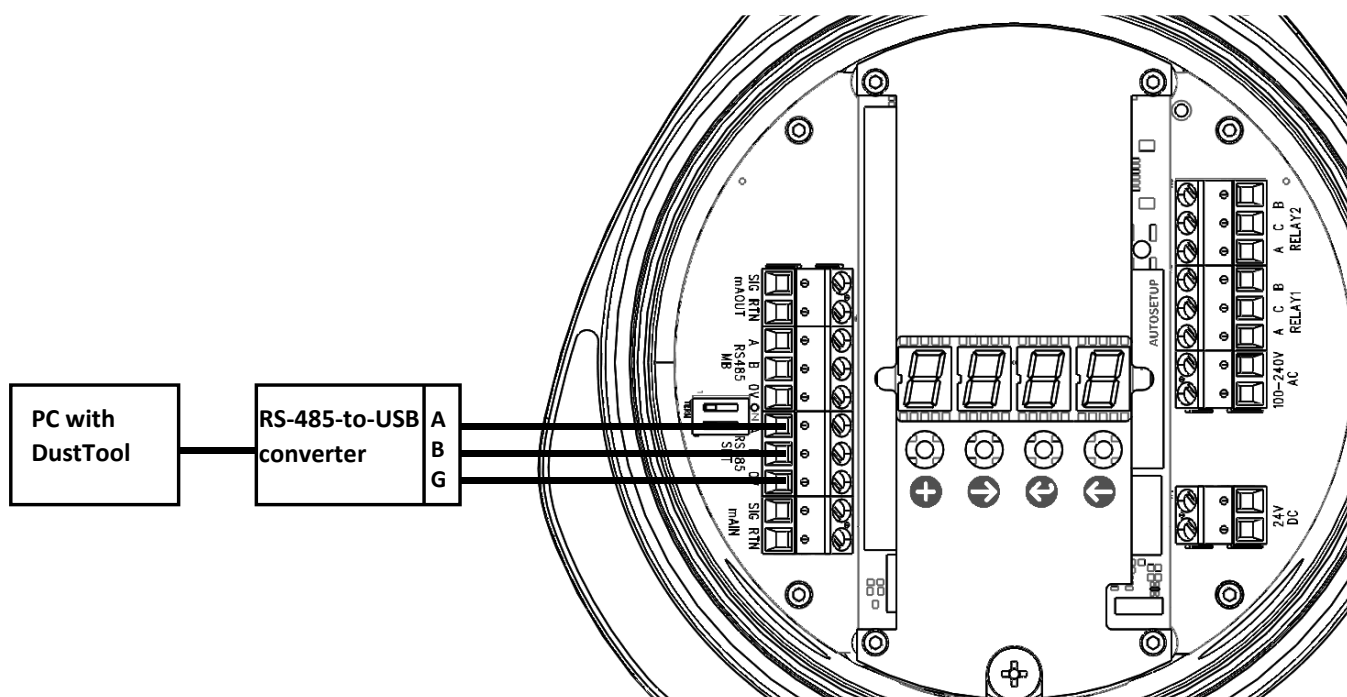

Figure 26: Sintról Network bus on the main board

To connect a RS-485 bus, you need:

- Protective gear for electric work
- Slotted-head screwdriver (M3)
- Wrench (20 mm [0.7874 in] or adjustable)
- Suitable signal cable

To connect a RS-485 bus:

1. Make sure that the device is not connected to the power supply, or that the power supply is disconnected or isolated.
2. Select whether you want to connect the MB or SNT bus.
 - For MB bus, use a 3-wire shielded twisted pair cable.
 - For SNT bus, use a RS-485-to-USB cable, or a converter with a suitable 3-wire shielded cable.

3. Remove the device lid by turning it counterclockwise to access the main board.

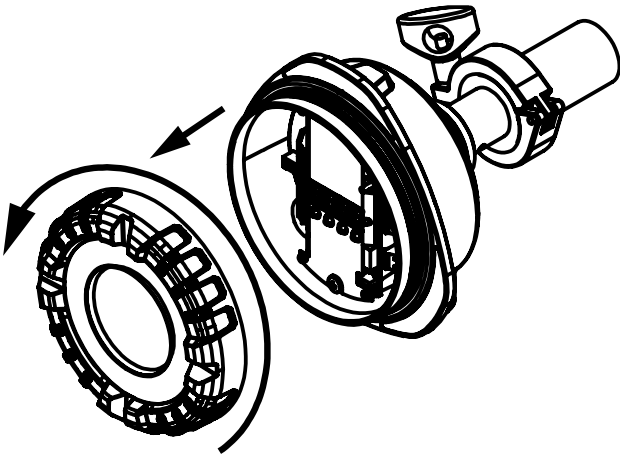

4. Remove the cable gland at the cable entry that is located on the left side of the device when you are facing the main board. Loosen the cable gland cap by turning it counterclockwise with a wrench.

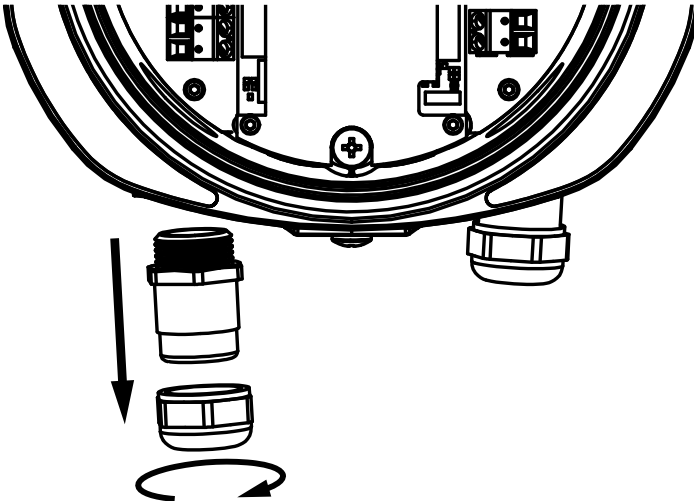

5. Slide the cable gland over the incoming signal cable.

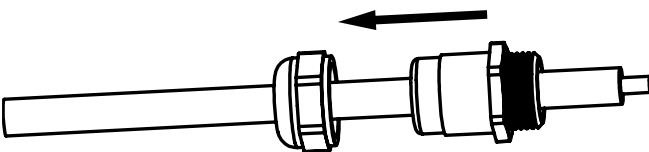

6. Insert the signal cable through the cable entry.

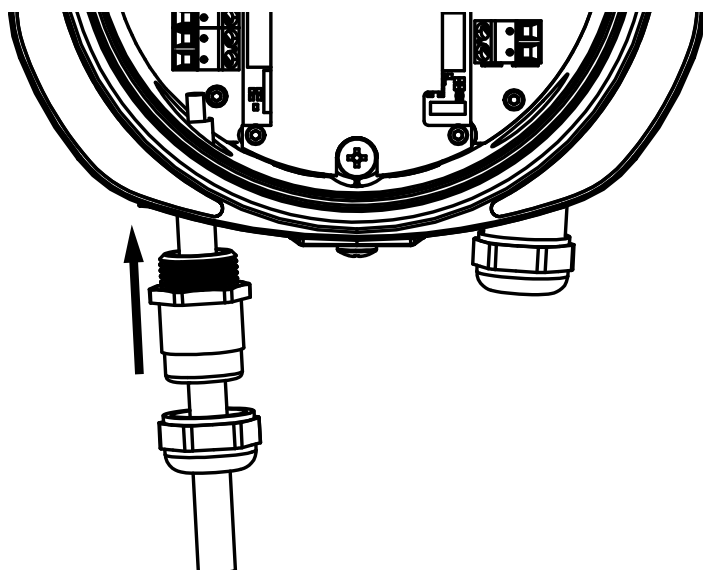

7. Connect the signal cable to the RS-485 output terminal block.

- For connecting multiple devices in parallel and controlling them with a Modbus master device or DustTool software, connect the RS-485 bus labeled “MB”.
- For connecting a single device to PC and controlling it with DustTool software, select the RS-485 bus labeled “SNT”.

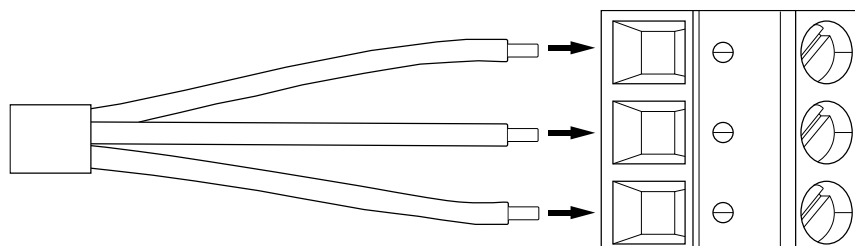

If you connect several devices in parallel with the MB bus, you must adjust the settings for each device in DustTool according to instructions in section “Wired device network” in chapter “Commissioning and system setup”.

8. Connect the other end of the signal cable to the application that receives the RS-485 output.

9. If you do not need to make any other electrical connections:

- Push the cable gland back inside the cable entry and tighten the cap with a wrench.

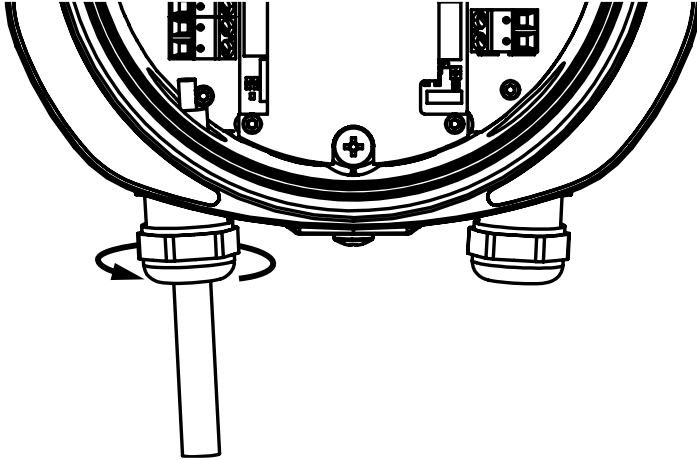

- Attach the device lid by tightening it clockwise.

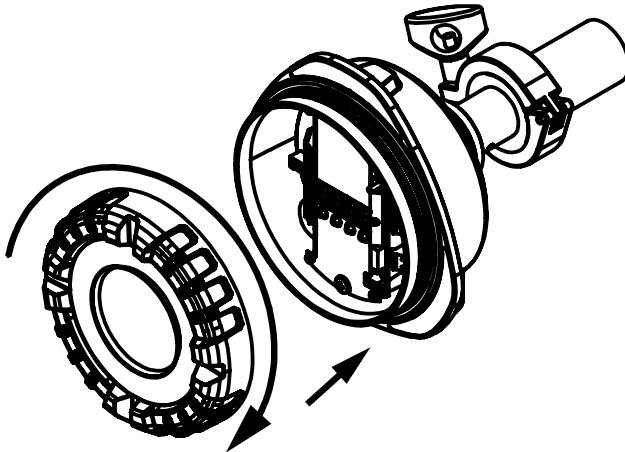

- Enable or connect the power supply, and power up the device.

Terminator switch

RS-485 bus (MB) allows multiple devices to be connected in parallel to create device chains and networks. The main board is equipped with a terminator switch for each RS-485 bus, labeled “1” for MB bus and “2” for SNT bus. The terminator switch must be turned ON or OFF on each device based on their position in the chain.

The switch must be in ON position only for the last device of the chain. On all other devices, the terminator switch must be in OFF position.

Table 7: Terminator switch configurations

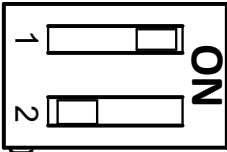
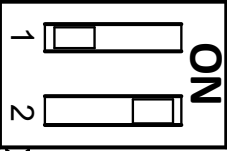
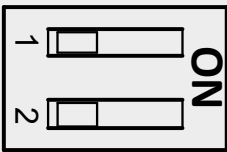
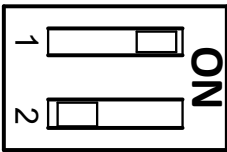
Device position	RS-485 bus	Switch position	Note
Single device	MB		A single connected device is always considered the last in a chain. If a single device is connected to either RS-485 bus, switch the corresponding terminator switch to “ON” position.
	SNT		
First or middle in chain	MB		If the device is the first in a chain or in the middle of a chain, make sure that the terminator switch is in OFF position.
	SNT	<i>Not applicable to SNT bus</i>	SNT bus is used for connecting single devices only, so this position does not apply.
Last in chain	MB		If the device is the last in a chain, make sure that the terminator switch is in OFF position.
	SNT	<i>Not applicable to SNT bus</i>	SNT bus is used for connecting single devices only, so this position does not apply.



The position of the terminator switch is independent of the communication protocol and must be set according to the RS-485 bus in use. A device network connected with MB bus can use either Modbus RTU or Sintrol Network protocol for communication.

6.3.8 Connecting with USB

It is possible to connect the device directly to a computer with USB without any additional equipment if the USB port of the host computer can supply enough power. This connection type can be used to change the parameters and settings of the device in DustTool.

Table 8: USB specifications

USB type:	Micro-B
Max. cable length:	5 m (16.4 ft)

The USB port is located on the bottom-right corner of the main board inside the enclosure.



Do not use the USB connection to operate the device for extended periods of time. The USB connection does not replace a dedicated industrial power supply, and it is not intended for extended use in normal operation.

6.3.9 Analog mA input



This feature is only available in model S304.

Model S304 has an option to compensate the changes in flow velocity by connecting the mA output of an external flowmeter to the analog mA input on the main board of the device.

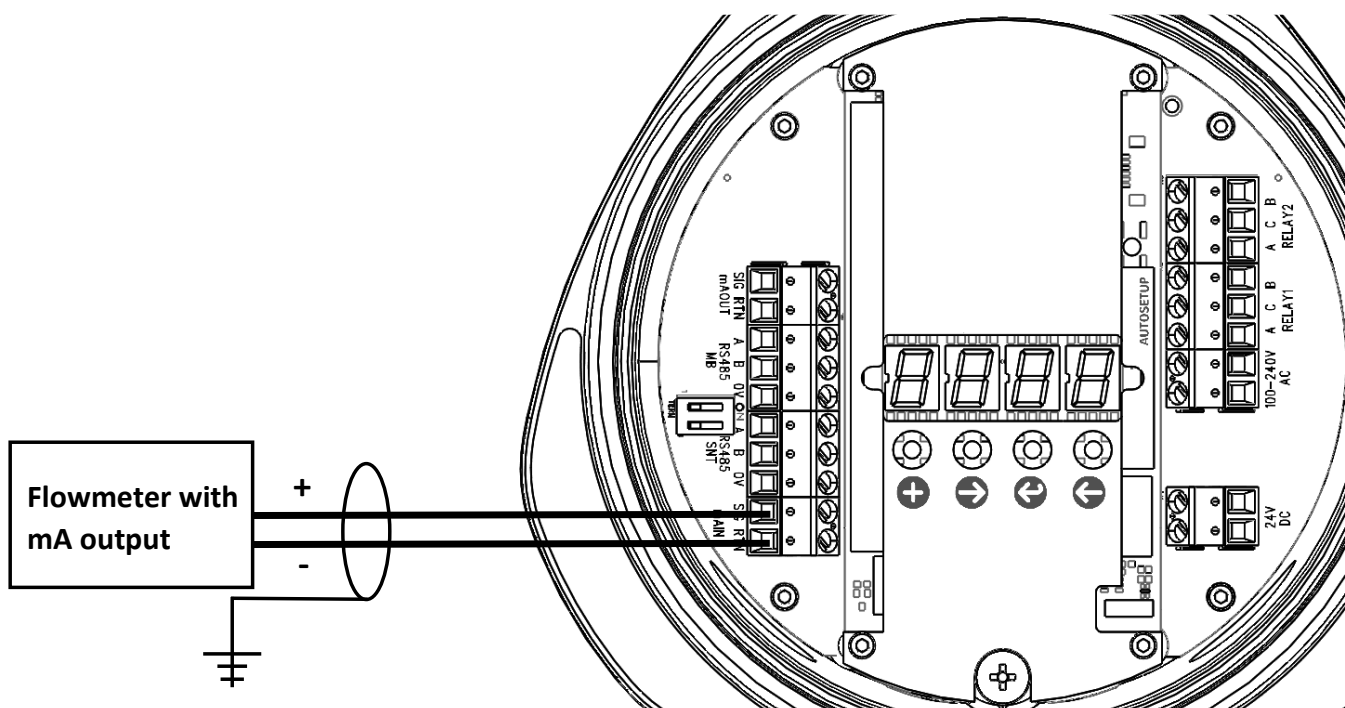

Figure 27: mA input on the main board



Connect the sheath of a shielded cable to ground on one end only. Connecting both ends to ground can create a ground loop.

To connect the mA input, you need:

- Protective gear for electric work
- Slotted-head screwdriver (M3)
- Wrench (20 mm [0.7874 in] or adjustable)
- Suitable signal cable

To connect the mA output from an external flowmeter to the mA input of the device:

1. Make sure that the device is not connected to the power supply, or that the power supply is disconnected or isolated.

2. Remove the device lid by turning it counterclockwise to access the main board.

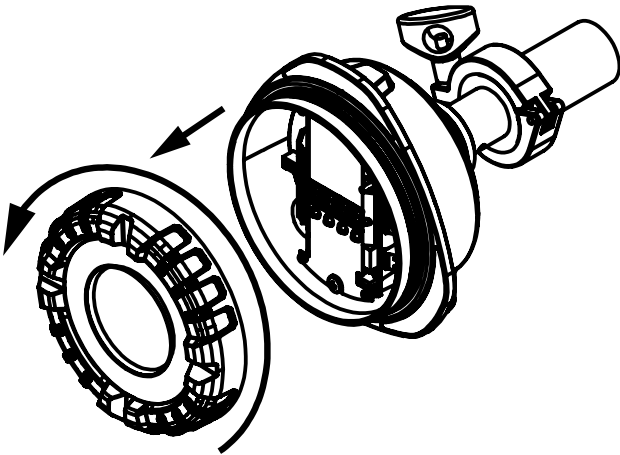

3. Remove the cable gland at the cable entry that is located on the left side of the device when you are facing the main board. Loosen the cable gland cap by turning it counterclockwise with a wrench.

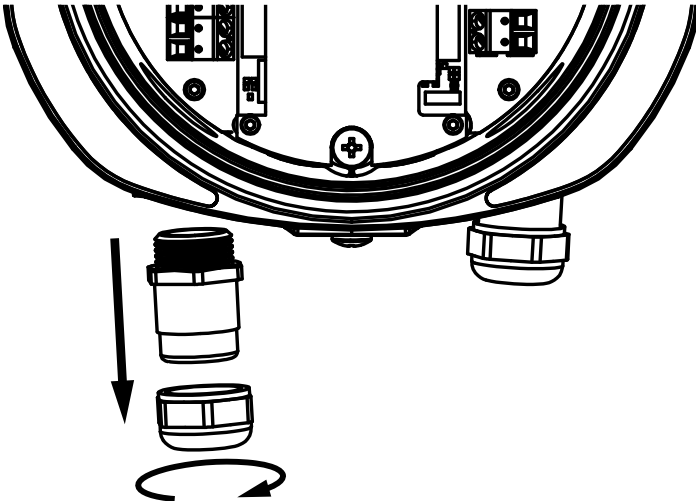

4. Slide the cable gland over the incoming signal cable.

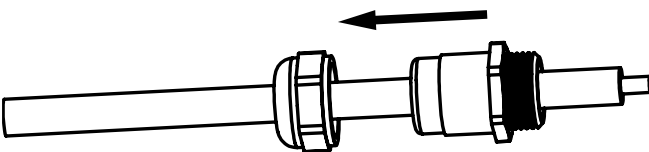

5. Insert the signal cable through the cable entry.

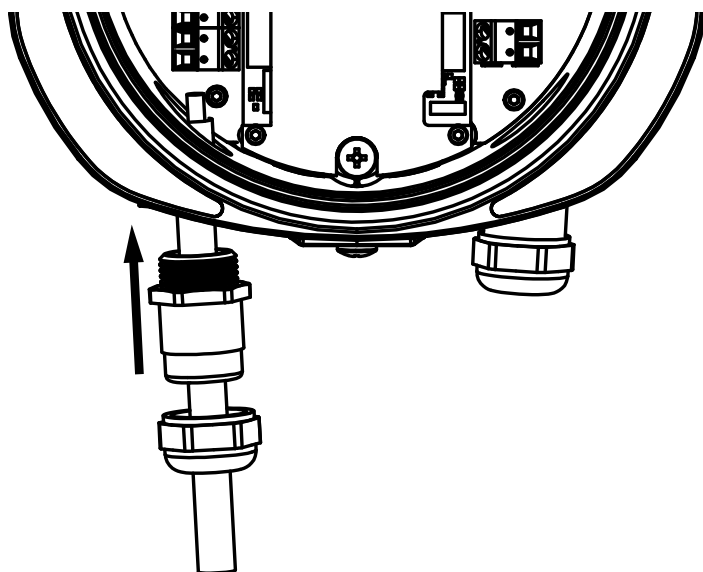

6. Connect the signal cable to mA input terminal block.
Insert the wires to the terminal block and tighten the screws.

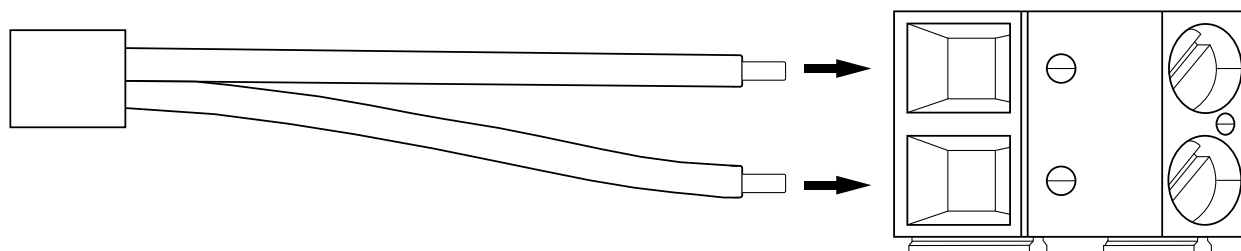

7. Connect the other end of the signal cable to the mA output of the external flowmeter.

8. If you do not need to make any other electrical connections:

- Push the cable gland back inside the cable entry and tighten the cap with a wrench.

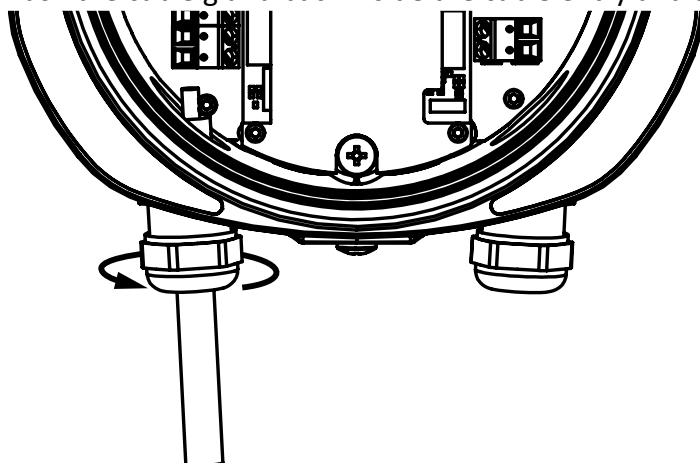

- Attach the device lid by tightening it clockwise.

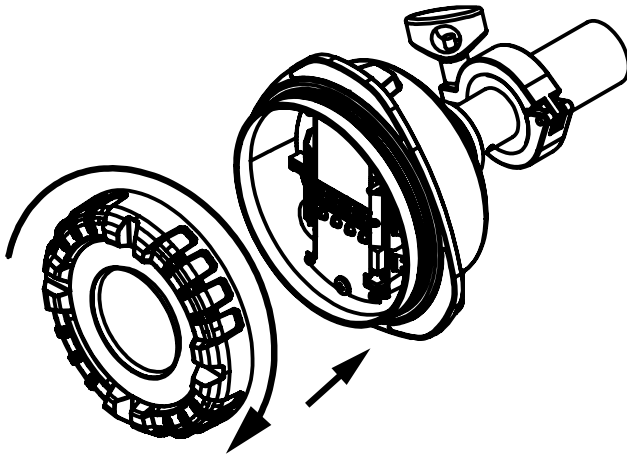

- Enable or connect the power supply, and power up the device.

7 DustTool

7.1 Overview

DustTool is a complementary software that can be used to control the parameters and features of the device with a Windows computer. The device can be connected to a computer running DustTool directly with USB or using RS-485-to-USB converter, Sintrol Router or Wireless Router.



To enable communication using RS-485 protocol, the device must have firmware version 3.0.2 or later, and the host computer must have DustTool version 1.2.1701101750 or later installed. You can check the firmware version in DustTool on PROPERTIES tab.



If you enable Lock Password feature in DustTool, it is no longer possible to run Auto Setup or change the device parameters. If you forget the password, you must contact Sintrol support to unlock the device with a device-specific master password.

You can download DustTool free of charge at <https://sintrol.com/product/dusttool/>.



DustTool is developed to set up and manage the device parameters and properties. If you need to save measurement data, create additional alarms, generate reports or access measurement history, monitoring software DustLog 10 is required.

7.2 System requirements

DustTool is developed for Windows operating system. See Table 9 for system requirements.

Table 9: System requirements for DustTool

Minimum		Recommended	
Operating system:	Windows XP	Operating system:	Windows 10
Display:	1024×768	Display:	1920×1080
RAM:	512 MB	RAM:	4 GB

7.3 Main view

When you launch DustTool, it looks up any connected Sintrol devices. The software automatically detects the interface that is used for communication and connects to the device. Connected devices appear on the main view of the software, where you can manage them.

Figure 28 shows the main view that opens each time DustTool is launched.

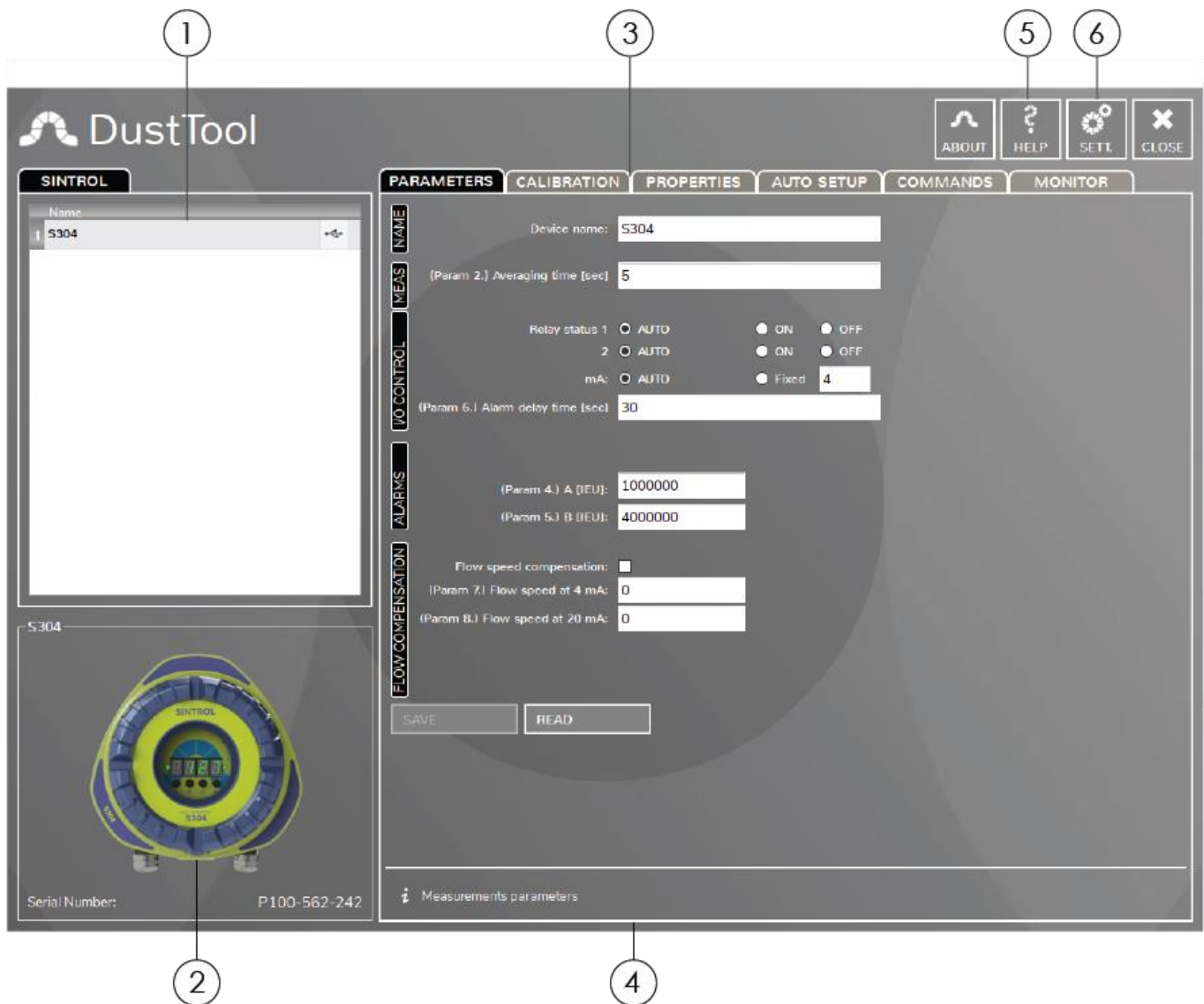

Figure 28: DustTool main view

- ① List of currently connected products. Connection type is displayed with a small icon next to the device name.
- ② Description of the selected product with the model name, serial number and picture.
- ③ Tabs help navigate the software, and manage device features related to calibration, parameters, Auto Setup, and commands. Monitor view provides a visualization of the current process conditions.
- ④ Info area on the bottom of the window displays information about the fields and items on the screen when you hover the mouse cursor over them.
- ⑤ Help view provides direct access to documentation related to the connected devices. In order to access user documentation, network access must be enabled.
- ⑥ Settings give you full control over software properties, like updates and network access.

8 Commissioning and system setup

The device requires minimal setup to establish regular operating condition. For basic trend monitoring applications, it is enough to only run the Auto Setup procedure. After commissioning and setting up the device, you can adjust parameter settings and alarm thresholds manually.

8.1 Auto setup

8.1.1 Overview



Parameters of the Auto Setup feature can be modified with DustTool software. This section only describes the default Auto Setup with factory settings.

In normal operation, the device continuously monitors the dust concentration in the airflow. During Auto Setup, the device analyzes the present measurement signal, determines an average signal level and establishes normal process conditions that are used as a baseline for future measurements.

Auto Setup also sets up two alarm thresholds (ALERT and ALARM) that are proportional to the normal dust level. An alarm is triggered when the dust concentration exceeds the configured dust level threshold.

Auto Setup is performed during normal operating conditions after the device is installed, and the process that the device monitors is running.



Make sure that Auto Setup is performed during normal operating conditions and usual dust levels. Performing Auto Setup during irregular conditions can result in false measurement results.

During Auto Setup, the device always uses the default settings for signal averaging time (50 seconds) and alarm delay time (30 seconds). Signal averaging time determines the period from which the device calculates the average signal level, and alarm delay time determines how long the dust level must be above the configured ALERT or ALARM threshold before the relays switch position and trigger the alarms.

Auto Setup takes 500 seconds (approximately 8 minutes) to complete. After Auto Setup is completed or cancelled, signal averaging time and alarm delay time automatically revert to their user-set values.

8.1.2 Operation statuses

Table 10 shows the default signal levels for each operation status after Auto Setup:

Table 10: Default signal levels after Auto Setup

Status	Output signal	Description
Normal:	4 ... 20 mA	Normal operation range
No dust present:	4 mA	Minimum value during normal operation

Status	Output signal	Description
Measurement baseline:	4.8 mA	5% of signal range
ALERT:	≥ 8 mA	<ul style="list-style-type: none"> • 5× increase in dust concentration • 25% of signal range • Relay 1 switches position
ALARM:	20 mA	<ul style="list-style-type: none"> • 20× increase in dust concentration • 100% of signal range • Relay 2 switches position

For further information on operation statuses and relay logic, see section **Relay, LED and display functional logic** in chapter **Operation**.

Figure 29 further illustrates the relation between Auto Setup baseline and the alarm thresholds:

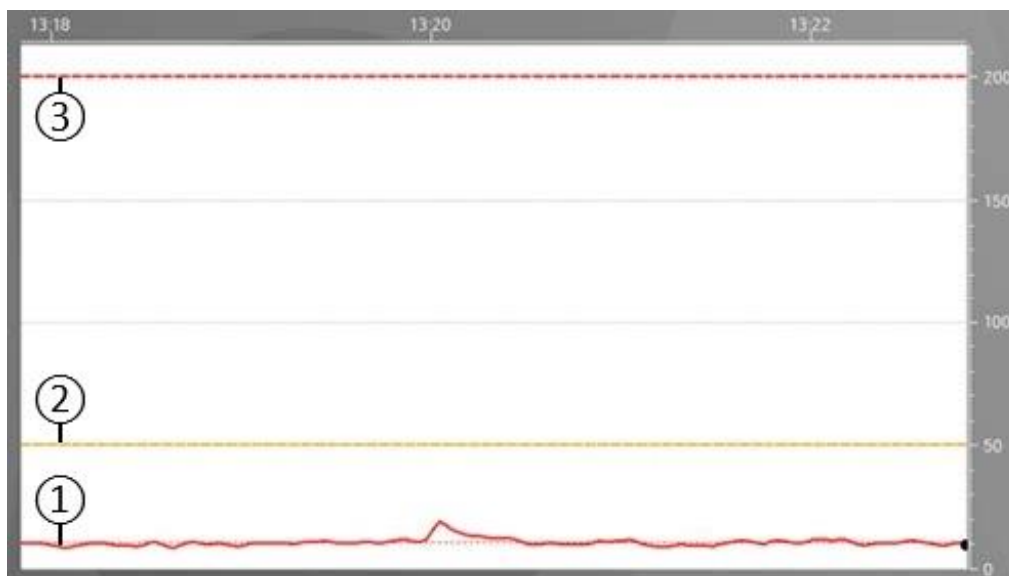

Figure 29: Relation between the output signal baseline and alarm thresholds after Auto Setup

①	Average output signal. Dust concentration baseline in the example is 10 mg/m^3 . Output signal is around 4.8 mA, which represents 5% of measurement range.
②	Dust ALERT threshold at 25% of measurement range. ALERT is triggered when there is a 5× increase in dust level compared to the baseline. In the example this corresponds to an output signal of 8 mA and a dust concentration of 50 mg/m^3 .
③	Dust ALARM threshold at 100% of measurement range. ALARM is triggered when there is a 20× increase in dust level compared to the baseline. In the example this corresponds to an output signal of 20 mA and a dust concentration of 200 mg/m^3 .

The actual dust concentration at the baseline depends on the location of the measurement point. If the measurement point is located before a filtration system, the baseline can be several g/m^3 . If the measurement point is located after a filtration system, the baseline can be only a few mg/m^3 . In both cases, no manual range setup is necessary.

8.1.3 Performing Auto Setup

The easiest way to perform Auto Setup is to start it manually on the main interface of the device. Only two keys, K0 (+) and AUTOSETUP, are required to perform Auto Setup. The keys are highlighted in Figure 30:



Figure 30: Main interface of the device with K0 (+) and AUTOSETUP keys highlighted

To perform Auto Setup:

1. Press K0 (+) key to enter MAINTENANCE mode. LEDs on both sides of the display start to blink, alternating between green and red.
2. Press AUTOSETUP key for 1 second. During Auto Setup:
 - The display shows the remaining time in seconds.
 - Both green LEDs continue to blink.
3. Auto Setup is completed when the counter reaches 0. The device resumes normal operation.

Auto Setup takes 500 seconds (approximately 8 minutes) to complete.



If you want to cancel Auto Setup, press AUTOSETUP key again for 1 second.

For a more detailed description of the main interface of the device, see section **Main interface** in chapter **Operation**.

8.2 Changing parameters

8.2.1 Main interface

You can change parameters manually with the main interface of the device.



Figure 31: Main interface of the device

To change a parameter with the main interface:

1. Press K0 (+) key to enter MAINTENANCE mode.
 - LEDs on both sides of the display blink, alternating between green and red.
 - The cursor position is indicated with a blinking digit.
2. Select the parameter you want to edit.
 - The selected parameter is displayed in display position D0.
 - Press K0 (+) key to select the next parameter.
 - Value of the selected parameter is displayed in positions D1 ... D3.
3. Select the value you want to change by pressing K1 (→) key.
 - Pressing K1 (→) key moves the cursor one step to the right.
 - If the cursor reaches position D3 and you press the key again, the cursor returns to position D0.
4. Press K0 (+) key to increase the blinking value by 1. If the value reaches 9 and you press the key again, the value returns to 0.
5. Press K2 (⇐) key to save the new parameter value. After saving, the new parameter value comes into effect immediately, and the cursor returns to position D0.
6. Press K3 (⇐) key to exit MAINTENANCE mode and return to normal operation.



If you do not press any key on the main interface for 10 seconds, MAINTENANCE mode times out and the device returns to normal operation.

For detailed information on the device parameters, see section **Parameters** in chapter **Operation**.

Setting negative values

Some parameters allow you to set negative values. To set a negative value, simply press K0 (+) key until a minus sign appears on the display. Minus sign is always set in display position D1, so for parameter value “-8” the displays D1 ... D3 must indicate “- 0 8”.

8.2.2 DustTool software

You can modify the operating parameters of the connected device in DustTool.

To change the device parameters in DustTool:

1. Launch DustTool.
2. Connect the device to a Windows computer with USB or RS-485 interface.
 - The software automatically detects the interface that is used for communication and connects to the device.
 - If multiple devices are connected to the same computer, you must select the device you want to control from the list on the left side of the main view.
 - When connecting with USB, no external power is needed. If you use RS-485, first connect the device to a power supply.
3. Find the parameter that you want to edit.

Parameter settings are located on tabs PARAMETERS, CALIBRATION and COMMANDS.
4. Edit the parameter value.
5. Click the SAVE button on the bottom of the screen to store the changes in the device memory.



If you do not click the SAVE button, the changes to the parameter values are lost when you close the program or disconnect the device.

6. Click the READ button to view the parameter values that are currently stored in the device memory.

For a more detailed overview of the DustTool software, see chapter **DustTool**.

8.2.3 Modbus RTU and Sintrol Network protocol

You can edit the device parameters using RS-485 buses. The device has two isolated RS-485 buses. Buses are labeled “MB” and “SNT”.

Modbus RTU

You can use Modbus RTU protocol to control the device parameters with an automation control system or any Modbus master device. To enable communication through Modbus RTU, connect the device to the master device with the RS-485 bus labeled MB.

For information on how to control slave devices, refer to the user documentation of your Modbus master device or control system.

For a quick reference of the register definitions of the Modbus RTU interface, see **Appendix B: Modbus RTU registers**.

For information on how to connect the RS-485 bus, see section **Connecting RS-485 bus** in chapter **Electrical installation**.

Sintrol Network

You can use Sintrol Network protocol to connect the device to a computer running DustTool software.

To control the device parameters using Sintrol Network:

1. Connect the device to the computer with the RS-485 bus labeled SNT.
Use a RS-485-to-USB cable, or a converter with a suitable 3-wire shielded cable.
2. Use DustTool software to change the device parameters.

For information on how to change the device parameters using DustTool, see section **DustTool software** in this chapter. For a more detailed overview of the DustTool software, see chapter **DustTool**.

For information on how to connect the RS-485 bus, see section **Connecting RS-485 bus** in chapter **Electrical installation**.

8.2.4 Wireless connection

If your device is equipped with the optional RF antenna, you can use DustTool to remotely control the settings and parameters of devices that are part of a wireless network.

For information on how to change the device parameters using DustTool, see section **DustTool software** in this chapter. For a more detailed overview of the DustTool software, see chapter **DustTool**.

For information on how to enable wireless communication for the device, see section **Establishing wireless communication** in this chapter.

8.3 Setting up device network

RS-485 buses allow multiple devices to be connected in parallel to create a device network. This makes it possible to communicate with several devices at the same time with minimum wiring. Wired connections can use either Modbus RTU or Sintrol Network protocol for communication. Wireless communication, and combination of wired and wireless connections require the use of Sintrol Network protocol.

A complete measurement system that is based on Sintrol Network protocol can consist of up to 254 devices connected to a single network. These can be connected either wirelessly, with the RS-485 bus labeled MB, or with a combination of the two.

8.3.1 Naming devices

It is recommended to assign each device in the network a unique name before installation. Because the network is created automatically when Sintrol Network protocol is used, naming the individual devices makes it easier to identify them.

To assign a name to a device:

1. Launch DustTool.
2. Connect the device to a Windows computer with USB, or with RS-485 using the SNT bus.
 - The software automatically detects the interface that is used for communication and connects to the device.
 - If multiple devices are connected to the same computer, select the device you want to assign a name to from the list on the left side of the main view.



When connecting with USB, no external power is needed.

If you use RS-485, first connect the device to a power supply.

3. Navigate to PARAMETERS tab and assign an individual name for the device in the Device Name field.

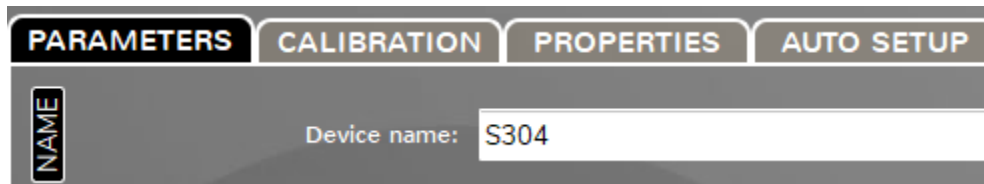

4. Click the SAVE button to store the new device name in the device memory.



5. Disconnect the device.

8.3.2 Wired device network

The device has two isolated RS-485 buses. Buses are labeled “MB” and “SNT”.

- MB bus is designed for connecting multiple devices into a single bus using either Modbus RTU or Sintrol Network protocol.
- SNT bus is designed for connecting a single device to a PC running DustTool software.

For creating a device network, you must use the bus labeled MB.

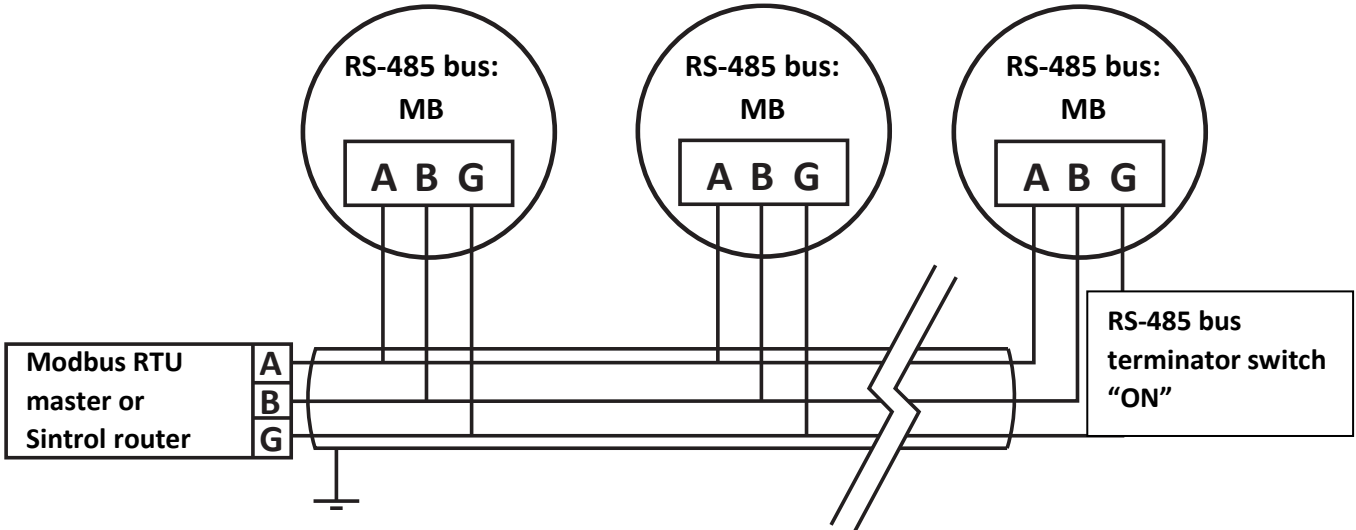

Figure 32: A device network created with RS-485 connections

To create a wired device network, you need:

- Communication base station
 - Modbus master device for Modbus RTU protocol
 - Network Router or Wireless Router for Sintrol Network protocol
- Suitable 3-wire shielded cable
- DustTool software

To set up a wired network, all devices in the chain must first be installed according to the instructions in chapters **Mechanical installation** and **Electrical installation**.

After the devices have been installed, the settings for each individual device must be adjusted in DustTool. To adjust the device settings in DustTool:

1. Connect the device to a computer with USB.
2. Launch DustTool and navigate to PROPERTIES tab.



3. Adjust the settings for the RS-485 protocol as necessary:

- To use Modbus RTU protocol and to control the device network with Modbus master device, select the option “Modbus Slave” and assign an appropriate unique slave ID. “Modbus Slave” is selected by default.

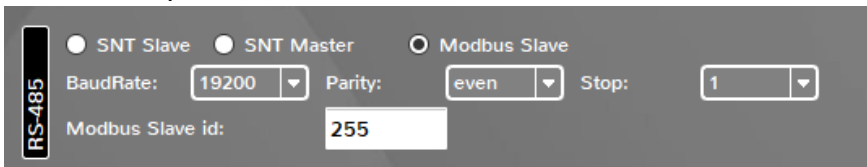

- To use Sintrol Network protocol and to control the device network with DustTool software and Network Router or Wireless Router, select the option “SNT Slave”.

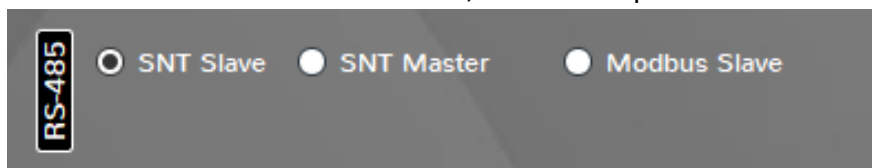

4. Click the SAVE button to store the new settings in the device memory.



5. Disconnect the device.
6. Repeat steps 1 to 4 for each individual device in the network.

After you have adjusted the settings for each individual device according to the selected communication protocol:

7. Switch the terminator switch 1 to ON position on the last device of the chain.

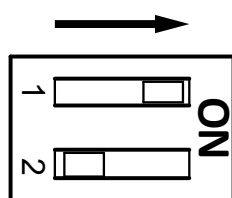

8. Connect the first device of the chain to the communication base station.
 - If your device chain communicates through Modbus RTU protocol, the first device in the chain must be connected to a Modbus master device.
 - If your device chain communicates through Sintrol Network protocol, the first device in the chain must be connected to Sintrol Router or Network Router. The router device in turn must be connected to a host computer.

The device network is now operational, and you can use the master device to control the devices.

8.3.3 Wireless device network

It is possible for multiple devices to communicate with each other using the optional radio frequency (RF) communication protocol. The wireless connection operates on the Sintrol Network protocol, which takes care of automatically forming the network. The measurement data is always transmitted using the strongest available connection.



If you want to use the wireless connections, you must have a RF-enabled version of the device. RF antenna cannot be retrofitted to non-RF models.

The network operates within the ISM radio bands, which do not require any permits or licenses to use.

Table 11: ISM frequency bands that the device uses

Frequency band	Geographical availability
868 MHz	Europe
915 MHz	North and South America, Australia



It is the responsibility of the end user to verify the available frequency bands and potential licensing needs in their area.

Sintrol Network protocol has a built-in support for wireless communication. This means that RF-enabled devices can operate seamlessly within the RS-485 network.

Establishing wireless communication

To establish a wireless connection, you need:

- A device equipped with the optional RF antenna
- Wireless Router
- DustTool software

To enable wireless connection:

1. Install the RF-enabled device as instructed in chapter **Mechanical installation**.
2. Install Wireless Router and connect it to the host computer as instructed in the related user manual.
3. Launch DustTool and select the router device from the list of connected devices.
4. Navigate to NETWORK tab.



5. NETWORK tab contains a graphical view of the device network. Right-click the icon of the router and select "Scan Network". The software automatically identifies the devices in the network and allows you to control their settings and parameters.

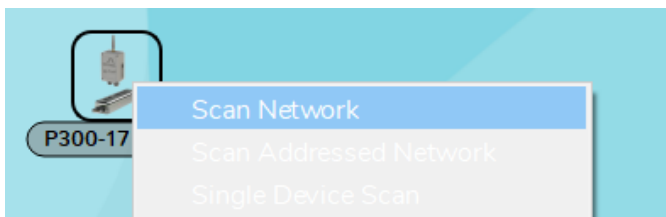

6. Close DustTool.

8.3.4 Combining wired and wireless connections in a network

Sintrol Network protocol supports communication using both the RS-485 bus and wireless RF connection. This means that it is possible to build a device network that uses both the wired and wireless connections.

To enable wireless communication in an existing device network that uses wired connections, at least one device in a device chain must be equipped with the RF capability. This device acts as a communication station that converts the physical signal from the other devices to radio frequencies. The communication station also converts radio frequencies from the host application to physical signals and passes them to the other devices in the network.

To manage the device network with a computer, connect a Wireless Router to a computer running DustTool. This router act as a base station for all communication between the control software and the device network. Figure 33 shows an example of a device network that uses both connection types:

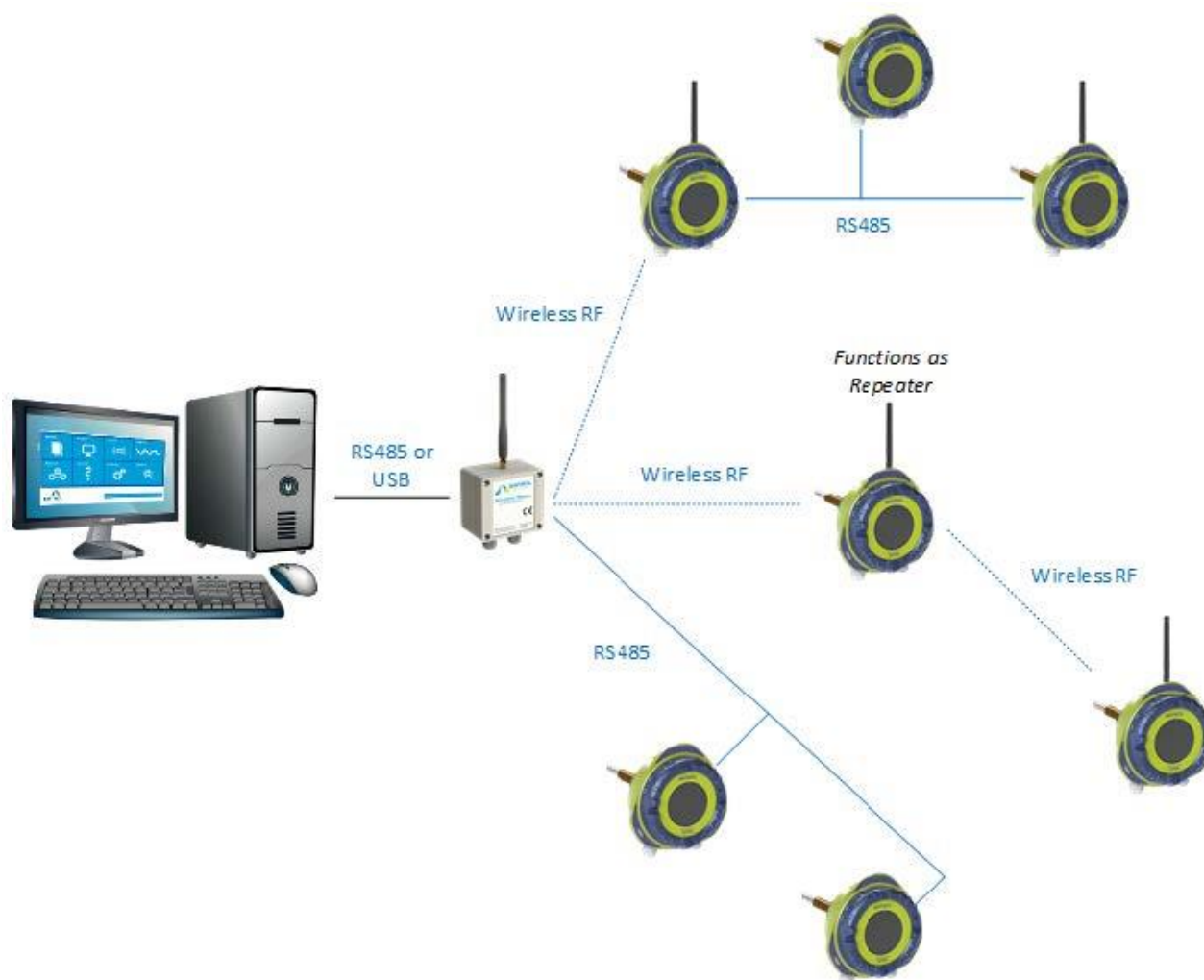

Figure 33: An example of a device network using Sintrol Network protocol with wired and wireless connections

9 Operation

9.1 Main interface

The main interface of the device is equipped with a 7-segment display with four digits, and five keys that are used to operate the device manually. In normal operation, the display shows the measurement result as a percentage of total range (0 ... 100%) or as a measurement value in mA or mg/m³.

You can change the display unit with **Parameter 1: Display unit**. See section **Parameters** for more information.

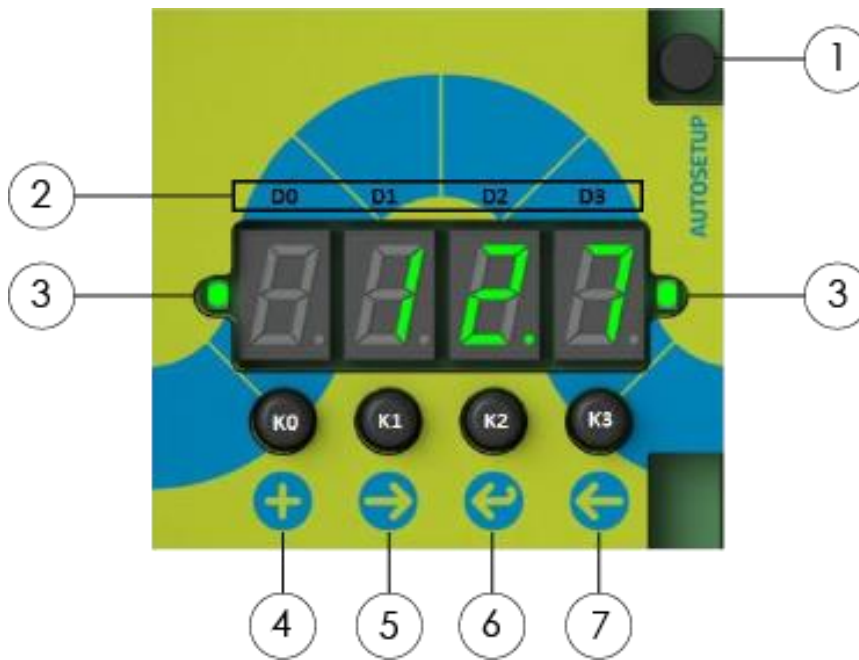

Figure 34: The main interface of the device

①	AUTOSETUP key. Performs Auto Setup.
②	7-segment display with four digits.* <ul style="list-style-type: none"> In normal operation, indicates the measurement value. In MAINTENANCE mode: <ul style="list-style-type: none"> Position D0 indicates the active parameter number. Positions D1 ... D3 indicate the parameter value.
③	Green and red status LEDs.
④	K0** (+) key. <ul style="list-style-type: none"> Enters MAINTENANCE mode. Increases the value of the selected, blinking digit by 1.
⑤	K1 (→) key. Moves the cursor one step to the right.
⑥	K2 (⇐) key. Saves the active parameter value.
⑦	K3 (←) key. Exits and returns the device to normal operation.

* Display position labels D0 ... D3 are included in this manual for reference purposes only. They are not printed on the device.

** Key labels K0 ... K3 are included in this manual for reference purposes only. They are not printed on the device.

9.2 Relay, LED and display functional logic

The device has various operation statuses that are indicated to the user with a combination of LEDs, two relays and a 7-segment display with four digits.

9.2.1 Operation statuses

The operation statuses are described in Table 12:

Table 12: Operation statuses and their descriptions

Device status	Description
NORMAL OPERATION	<ul style="list-style-type: none"> The device operates normally according to the initial setup and generates a valid output signal. The output signal is below the configured thresholds for ALERT and ALARM statuses.
ALERT	<ul style="list-style-type: none"> The device operates normally according to the initial setup and generates a valid output signal. The output signal is above the configured threshold for ALERT status. The output signal is below the configured threshold for ALARM status.
ALARM	<ul style="list-style-type: none"> The device operates normally according to the initial setup and generates a valid output signal. The output signal is above the configured threshold for ALARM status.
AUTO SETUP	<ul style="list-style-type: none"> The device analyzes and establishes normal process conditions that are used as a baseline for future measurements. The device does not generate a valid output signal.
MAINTENANCE	<ul style="list-style-type: none"> The device has been manually set into MAINTENANCE mode. The device does not generate a valid output signal.
ZERO/SPAN CHECK	<ul style="list-style-type: none"> The device performs zero/span check automatically at a certain interval, when the measurement range settings are changed, and after each time Auto Setup is performed. Measurement drift is automatically corrected if it is >3% but <10% of the measurement range. If the drift is >10% or if the device is unable to correct the drift, the device enters FAULT mode. The device generates an output signal according to pre-determined test values.
FAULT	<ul style="list-style-type: none"> The device has detected a fault in the operation. The device does not generate a valid output signal.

9.2.2 Relay logic

The device has two Single Pole Double Throw (SPDT) relays. The contacts are labeled A, B and C, with C being the common contact. The relays can be used to control external loads of up to 240 V AC / 5 A or 30 V DC / 5 A.

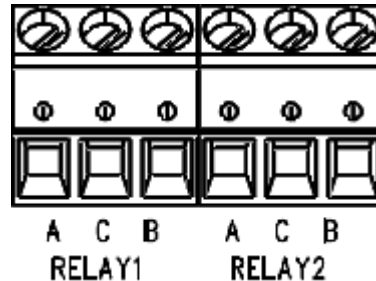
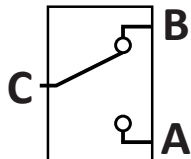
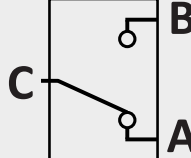

Figure 35: Relay terminals on the device main board

Both relays are energized during normal operation, which means that voltage is applied to the electromagnetic coils. When the dust level exceeds the configured alarm thresholds, the voltage is no longer supplied, and the relays are relaxed.

Table 13: Relay statuses

Relay status	Relay contacts	
Energized	C-A: open C-B: closed	
Relaxed	C-A: closed C-B: open	

The operation logic of the relays is described in Table 14:

Table 14: Operation logic of the relays

Device status	RELAY1 status	RELAY1 contacts	RELAY2 status	RELAY2 contacts	Analog signal (mA)
NORMAL OPERATION	Energized	C-A: open C-B: closed	Energized	C-A: open C-B: closed	According to dust level
ALERT	Relaxed	C-A: closed C-B: open	Energized	C-A: open C-B: closed	According to dust level
ALARM	Relaxed	C-A: closed C-B: open	Relaxed	C-A: closed C-B: open	According to dust level
AUTO SETUP	Energized	C-A: open C-B: closed	Relaxed	C-A: closed C-B: open	>22 mA
MAINTENANCE	Energized	C-A: open C-B: closed	Relaxed	C-A: closed C-B: open	According to dust level

Device status	RELAY1 status	RELAY1 contacts	RELAY2 status	RELAY2 contacts	Analog signal (mA)
ZERO/SPAN CHECK	Energized	C-A: open C-B: closed	Relaxed	C-A: closed C-B: open	4 mA for Zero check, approx. 16.8 mA for Span check
FAULT	Relaxed	C-A: closed C-B: open	Relaxed	C-A: closed C-B: open	>22 mA

9.2.3 LED and display logic

The main interface of the device is equipped with a 7-segment display with four digits, and green and red LEDs on each side of the display. The LEDs are mirrored, and their function is the same regardless of their location on the main interface.

The operation logic of the display and LEDs is described in Table 15:

Table 15: Operation logic of the LEDs and display

Device status	Green LED	Red LED	Display
NORMAL OPERATION	ON	OFF	Displays current dust level
ALERT	ON*	ON*	Displays current dust level
ALARM	OFF	ON	Displays current dust level
AUTO SETUP	Blinks	OFF	Countdown (sec)
MAINTENANCE	Blinks between green and red with 500 ms interval	Blinks between red and green with 500 ms interval	Number and value of active parameter
ZERO/SPAN CHECK	Blinks between green and red with 500 ms interval	Blinks between red and green with 500 ms interval	Output signal
FAULT	OFF	Blinks between left and right with 500 ms interval	Error code

* With both red and green LEDs ON, the color appears orange.

To test that the display and LEDs are operating normally, press K0 (+) and K3 (←) keys at the same time. All four displays are activated, displaying “8.8.8.8.”, and status LEDs on each side of the display are illuminated. This indicates that the display and LEDs are operating as intended.

For descriptions of error codes, see section **Error codes in FAULT mode**.

9.3 Parameters

For instructions on how to change the device parameters, see section **Changing parameters** in chapter **Commissioning and system setup**.

9.3.1 Overview

You can control how the device operates and reacts to changes in dust levels by adjusting the device parameters. To change parameter values on the main display, enter MAINTENANCE mode by pressing K0 (+) key. The device indicates the parameter number on the display position D0, and parameter values on positions D1 ... D3.

Because only one display position is reserved for the parameter number, 2-digit parameters are indicated in an abbreviated form. Parameter 10 is indicated as 0, and parameters 11 to 17 as 1., 2., 3. and so on, with a single digit followed by a period.

See Table 16 for information on the device parameters and their availability on different device models:

Table 16: The device parameters

No.	Parameter	Value	√=Available	×=Not available	S303	S304
1	Display unit	000: Displays measurement range in %. Default value.	√	√	√	√
		001: Displays output signal level in mA.	√	√	√	√
		002: Displays dust concentration in mg/m ³ . Displays -.-.- if mg/m ³ is disabled.	×	√	×	√
2	Signal averaging time (sec)	000 ... 300 Default = 50 sec	√	√	√	√
3	Measurement range (%)	000 ... 999 Default = 100% (20× the baseline value calibrated during Auto Setup)	√	√	√	√
4	ALERT threshold (% of range)	000 ... 100 Default = 25% (8 mA)	√	√	√	√
5	ALARM threshold (% of range)	000 ... 100 Default = 100% (20 mA)	√	√	√	√
6	Alarm delay time (sec)	000 ... 180 Default = 30 sec	√	√	√	√
7	Flow velocity compensation at 4 mA (m/s)	000 ... 99.9 Default = 0 m/s (no compensation)	×	√	×	√
8	Flow velocity compensation at 20 mA (m/s)	000 ... 99.9 Default = 0 m/s (no compensation)	×	√	×	√
9	Zero/span check interval (hours)	000 ... 999 Default = 0 hours (no check)	×	√	×	√
0 (10)	Command parameter	001: Reset to factory default	√	√	√	√
		002: Enable mg/m ³ calibration	×	√	×	√
		003: Disable mg/m ³ calibration	×	√	×	√
1. (11)	Integer part of x-intercept α	-99 ... 099 Default = 0 mg/m ³	×	√	×	√

No.	Parameter	Value	√=Available	×=Not available	S303	S304
2. (12)	Decimal part of x-intercept α	000 ... 999 Default = 0 mg/m ³			×	✓
3. (13)	Integer part of slope β	000 ... 999 Default = 0 mg/m ³ per mA			×	✓
4. (14)	Decimal part of slope β	000 ... 999 Default = 0 mg/m ³ per mA			×	✓
5. (15)	20 mA scaling × 1 000 000 IEU	000 ... 999			×	✓
6. (16)	20 mA scaling × 1000 IEU	000 ... 999			×	✓
7. (17)	Firmware version	Displays current firmware version.			✓	✓

9.3.2 Parameter 1: Display unit

Parameter 1 is used to determine the unit that the device uses when it displays the measurement signal level. See Table 17 for descriptions of the parameter values:

Table 17: Parameter 1 values

Value	Description	Display
000	Displays measurement range in %. Default value.	0.0 ... 100.0 (%), fixed decimal point
001	Displays output signal level in mA.	04.00 ... 20.00 (mA), fixed decimal point
002*	Displays dust concentration in mg/m ³ .	00.01 ... 999.9 ... 9999 (mg/m ³), floating decimal point

* Only available in model S304.



If the mA output is not properly connected and parameter value 001 is selected, the display indicates “OL” for “Open Loop”. This means that the 4 ... 20 mA loop is not closed.

The device indicates the currently selected measurement unit every 8 seconds by showing it on the display for 2 seconds. For parameter value 000 the device displays “%”, for parameter value 001 it displays “mA” and for 002 it displays “mg”.

9.3.3 Parameter 2: Signal averaging time

Signal averaging time refers to the period from which the device calculates the average signal level. For example, with the default value of 50, the displayed measurement result is the moving average of the past 50 seconds.

Parameter value corresponds to the signal averaging time in seconds.

Table 18: Parameter 2 values

Value range (sec)	Description	Default
000 ... 300	Determines the signal averaging time in seconds.	50

When adjusting the parameter value locally with the device main interface, the maximum signal averaging time is 300 seconds. However, with DustTool you can set the signal averaging time to up to 6000 seconds.

9.3.4 Parameter 3: Measurement range

Parameter 3 value controls the maximum measurement range in relation to the baseline value that is determined during Auto Setup. You can control the maximum dust concentration that the device can detect before reaching the maximum output signal of 20 mA by changing the parameter value. This scales the whole measurement range to the standard 4 ... 20 mA signal range.



If Auto Setup has not been performed, the display indicates “3 - -” when this parameter is selected.

Table 19: Parameter 3 values

Value range (%)	Description	Default
000 ... 999	Increases or decreases the maximum dust concentration at 20 mA output signal.	100

With the default value, the device can detect a 20× increase in the dust level in relation to the baseline before reaching 20 mA signal level. This represents 100% of the default measurement range.



The maximum range determined with parameter 3 is always calculated from the baseline value. In practice, parameter 3 value sets a multiplier for how much the dust concentration can increase before the output signal reaches 20 mA.

See Table 20 for examples on how changing the parameter value affects the measurement range:

Table 20: Examples of adjusting the measurement range with parameter 3

Value (%)	Description	Dust level at 20 mA
050	Halves the measurement range	10× baseline
100	Default value	20× baseline
200	Doubles the measurement range	40× baseline



After adjusting the measurement range, the device automatically performs zero/span check.



Adjusting the measurement range does not change the dust concentrations required to trigger ALERT and ALARM statuses. Instead, it adjusts parameter 4 and 5 values in relation to the new maximum range. For example, doubling the measurement range with parameter 3 halves the values of parameters 4 and 5.

For detailed information on the default measurement range and signal levels, see section **Auto setup** in chapter **Commissioning and system setup**.

9.3.5 Parameter 4: ALERT threshold

Parameter 4 controls the relation between the maximum measurement range (adjusted with parameter 3) and the ALERT status threshold. Parameter value corresponds to the signal level required to trigger the ALERT status.

Table 21: Parameter 4 values

Value range (%)	Description	Default
000 ... 100	Increases or decreases the signal level required to trigger the ALERT status.	025

See Table 22 for examples on how the parameter value affects the signal level required to trigger the ALERT status.

Table 22: Examples of adjusting ALERT threshold with parameter 4

Value (%)	Description
012	Halves the default signal level. ALERT triggers at 12% of maximum range.
025	Default value. ALERT triggers at 25% of maximum range.
050	Doubles the default signal level. ALERT triggers at 50% of maximum range.



ALERT threshold is set in relation to maximum measurement range, which is determined with parameter 3. These two parameters are not linked and must be set independently. For example, if you double the maximum measurement range, the default parameter 4 value is decreased from 025 to 012 (25% to 12% of maximum measurement range).

9.3.6 Parameter 5: ALARM threshold

Parameter 5 controls the relation between the maximum measurement range (adjusted with parameter 3) and the ALARM status threshold. Parameter value corresponds to the signal level required to trigger the ALARM status.

Table 23: Parameter 5 values

Value range (%)	Description	Default
000 ... 100	Increases or decreases the signal level required to trigger the ALERT status.	100

See Table 24 for examples on how the parameter value affects the signal level required to trigger the ALARM status.

Table 24: Examples of adjusting ALARM threshold with parameter 5

Value (%)	Description
050	Halves the default signal level. ALARM triggers at 50% of maximum range.
100	Default value. ALARM triggers at 100% of maximum range.



ALARM threshold is set in relation to maximum measurement range, which is determined with parameter 3. These two parameters are not linked and must be set independently. For example, if you double the maximum measurement range, the default parameter 5 value is decreased from 100 to 050 (100% to 50% of maximum measurement range).

9.3.7 Parameter 6: Alarm delay time

Parameter 6 determines how long the average dust level must be above the configured ALERT or ALARM threshold before an alarm is triggered. This is to avoid false alarms caused by naturally occurring peaks in dust levels in certain processes.

Parameter value corresponds to the alarm delay time in seconds.

Table 25: Parameter 6 values

Value range (sec)	Description	Default
000 ... 180	Sets the alarm delay time in seconds.	30



Parameter 6 applies a delay to all relay position switches when the device changes its operation status. However, in practice this only affects the operation of the device in relation to ALARM and ALERT statuses.

9.3.8 Parameters 7 and 8: Flow velocity compensation



Parameters 7 and 8 are only available in model S304.

Flow velocity can have an impact on the measurement results. With model S304 you can compensate the influence that changes in flow velocity have on the signal level by connecting the mA output of an external flowmeter to the mA input of model S304.

For information on how to connect an external flowmeter to model S304, see section **Analog mA input** in chapter **Electrical connections**.

Parameter 7: Flow velocity at 4 mA

Use parameter 7 to set the flow velocity value that corresponds to the 4 mA output signal level from the external flowmeter. Parameter value corresponds to the flow velocity in m/s.

Table 26: Parameter 7 values

Value range (m/s)	Description	Default
00.0 ... 99.9	Sets the flow velocity corresponding to 4 mA output signal from the external flow meter.	00.0



Parameter value 00.0 means that flow velocity compensation is disabled.

Parameter 8: Flow velocity at 20 mA

Use parameter 8 to set the flow velocity value that corresponds to the 20 mA output signal level from the external flowmeter. Parameter value corresponds to the flow velocity in m/s.

Table 27: Parameter 8 values

Value range (m/s)	Description	Default
00.0 ... 99.9	Sets the flow velocity corresponding to 20 mA output signal from the external flow meter.	00.0



Parameter value 00.0 means that flow velocity compensation is disabled.

9.3.9 Parameter 9: Zero/span check interval



This parameter is only available in model S304.

Zero/span check is an automatic self-diagnostics procedure. During zero/span check, the device disconnects the sensor probe from the measurement chain and induces a computer-generated signal to the processing electronics. This is done to ensure that the measurement results match the factory-calibrated reference values. Parameter 9 controls how often the device performs zero/span check.

Parameter value corresponds to the zero/span check interval in hours.

Table 28: Parameter 9 values

Value range (h)	Description	Default
000 ... 999	Sets the zero/span check interval in hours.	000



Parameter value 000 means that the automatic zero/span check is disabled. The device performs zero/span check independently of the parameter 9 value each time you adjust the range setting with parameter 3, and each time Auto Setup is performed.

9.3.10 Parameter 10: Command parameter

Command parameter 10 can be used to reset the device to the default factory settings. With model S304 it is also possible to enable the device to display the measurement results in mg/m³.

See Table 29 for descriptions of the parameter values:

Table 29: Parameter 10 values

Value	Description
001	Reset all parameters to default factory values.
002*	Enable mg/m ³ calibration.
003*	Disable mg/m ³ calibration.

* Only available in model S304.

Reset to default factory values

To reset the device to the default factory settings:

1. Press K0 (+) key to enter MAINTENANCE mode.
2. Navigate to parameter 10.
3. Enter parameter value 001 and press K2 (↔) key to save the value.
4. Press K3 (←) key to exit and return to normal operation.

All device parameters are now overwritten with the default factory values.



Resetting the device to factory settings with command parameter 10 rewrites all parameter values, including the ones set with Auto Setup.

Enable mg/m³ calibration

To enable displaying the measurement results in mg/m³:

1. Press K0 (+) key to enter MAINTENANCE mode.
2. Enter the values α and β of the calibration equation $y_i = \alpha + \beta x_i$ to parameters 11, 12, 13 and 14. After setting the value for each parameter, save the value by pressing K2 (↔) key.

See section **Parameters 11 to 14: Displaying measurement results in mg/m³** for information about the calibration equation and individual calibration parameters.

3. Navigate to parameter 10.
4. Enter parameter value 002 and press K2 (↔) key to save the value.

5. Navigate to parameter 1.
6. Enter parameter value 002 and press K2 (↔) key to save the value.
7. Press K3 (←) key to exit and return to normal operation.

The measurement results are now displayed in mg/m³.

Disable mg/m³ calibration

To disable displaying the measurement results in mg/m³:

8. Press K0 (+) key to enter MAINTENANCE mode.
9. Navigate to parameter 10.
10. Enter parameter value 003 and press K2 (↔) key to save the value.
11. Navigate to parameter 1.
 - Enter parameter value 000 to display the measurement range in %.
 - Enter parameter value 001 to display output signal level in mA.



If you do not set a new value for parameter 1, the device alternates between displaying “-.-.-” and “mg” in normal operation mode.

12. Press K2 (↔) key to save the value.
13. Press K3 (←) key to exit and return to normal operation.

9.3.11 Parameters 11 to 14: Displaying measurement results in mg/m³



Parameters 11 to 14 are only available in model S304.

To enable the device to display the measurement results in mg/m³, the device must be calibrated by inserting values from a calibration equation to parameters 11, 12, 13 and 14. These values are calculated by utilizing a linear regression curve with an equation $y_i = \alpha + \beta x_i$. To determine the parameter values for parameters 11 to 14, you need to know the values for x-intercept α and slope β . The values are calculated from the results of a reference measurement. A commonly used method is gravimetric sampling.



This section describes how to perform the calibration using the local display. You can also use DustTool to calibrate the device to display measurement results in mg/m³.



After setting values for parameters 11 to 14, enable mg/m³ calibration with parameter 10 and set the local display to show measurement results in mg/m³ with parameter 1.

Example parameter values

For setting the parameters, values α and β are split into integer and decimal parts:

- Integer part of value α becomes the value for parameter 11.
- Decimal part of value α becomes the value for parameter 12.
- Integer part of value β becomes the value for parameter 13.
- Decimal part of value β becomes the value for parameter 14.

Table 30 uses example values to show how these values are used to set the parameter values for calibrating the device to display the measurement results in mg/m³:

Table 30: Example values for parameter 11 to 14

No.	Parameter	Calibration variable	Parameter value
1. (11)	Integer part of x-intercept α	$\alpha = -8.625$	-08
2. (12)	Decimal part of x-intercept α	$\alpha = -8.625$	625
3. (13)	Integer part of slope β	$\beta = 1.625$	001
4. (14)	Decimal part of slope β	$\beta = 1.625$	625

Parameter 11: Integer part of x-intercept α

Parameter 11 is used to set the calibration value for the integer part of x-intercept α when the device is calibrated to display measurement results in mg/m³.

Table 31: Parameter 11 values

Value range (mg/m ³)	Description	Default
-99 ... 099	Value for the integer part of x-intercept α .	000

Parameter 12: Decimal part of x-intercept α

Parameter 12 is used to set the calibration value for the decimal part of x-intercept α when the device is calibrated to display measurement results in mg/m³.

Table 32: Parameter 12 values

Value range (mg/m ³)	Description	Default
000 ... 099	Value for the decimal part of x-intercept α .	000

Parameter 13: Integer part of slope β

Parameter 13 is used to set the calibration value for the integer part of slope β when the device is calibrated to display measurement results in mg/m^3 .

Table 33: Parameter 13 values

Value range ($\text{mg}/\text{m}^3/\text{mA}$)	Description	Default
000 ... 099	Value for the integer part of slope β .	000

Parameter 14: Decimal part of slope β

Parameter 14 is used to set the calibration value for the decimal part of slope β when the device is calibrated to display measurement results in mg/m^3 .

Table 34: Parameter 14 values

Value range ($\text{mg}/\text{m}^3/\text{mA}$)	Description	Default
000 ... 099	Value for the decimal part of slope β .	000

9.3.12 Parameters 15 and 16: IEU to 20 mA scaling



Parameters 15 and 16 are only available in model S304.

Parameters 15 and 16 control the maximum measurement range by setting an IEU value that corresponds to the 20 mA output signal. This allows you to set the measurement range more accurately than with parameter 3, which controls the measurement range by setting a multiplier in relation to the baseline value.

The IEU scale ranges from 0 to several million units. Because of this, setting the IEU value is done with two parameters. Parameter 15 sets the IEU value in millions, and parameter 16 in thousands.

Table 35: Parameter 15 and 16 functions

No.	Parameter	Description
5. (15)	IEU units in millions	Parameter value represents \times million IEU units
6. (16)	IEU units in thousands	Parameter value represents \times thousand IEU unit

This means that for setting 20 mA to correspond to, for example, 125 020 000 IEU, the parameter values would be as shown in Table 36:

Table 36: Example parameter values for 125 020 000 IEU

No.	Parameter	Parameter value
5. (15)	IEU units in millions	125
6. (16)	IEU units in thousands	020



Adjusting the measurement range with parameters 15 and 16 overrides the previous range settings done using parameter 3.

Parameter 15: IEU units in millions

Parameter 15 sets the million part of the IEU value that corresponds to 20 mA output signal. Parameter value represents × million IEU units.

Table 37: Parameter 15 values

Value range (million IEU)	Description	Default
000 ... 999	Sets the million part of the IEU value	n/a

Parameter 16: IEU units in thousands

Parameter 16 sets the thousand part of the IEU value that corresponds to 20 mA output signal. Parameter value represents × thousand IEU units

Table 38: Parameter 16 values

Value range (thousand IEU)	Description	Default
000 ... 999	Sets the thousand part of the IEU value	n/a

9.3.13 Parameter 17: Firmware version

Parameter 17 is a read-only parameter. Navigating to it returns the current firmware version.



**The user cannot update the device firmware on-site.
To update firmware version, contact the manufacturer or an authorized distributor.**

9.4 Troubleshooting

If performing the checks as instructed in this section does not solve your problem, contact the manufacturer or an authorized distributor.

9.4.1 Error codes in FAULT mode

When the device enters FAULT mode, an error code is displayed on the local display. See below table for the error codes and their descriptions.

Table 39: Error codes

Error code	Description	Solution
Err1	Sensor probe grounded	Clean the probe.
Err2	Zero/span check failed	Check measurement response and return the device for repair.
Err3*	Flow compensation input failed	Verify mA output of the external flowmeter and check the device parameter values.
Err4	Auto Setup failed	Run Auto Setup again. If the issue persists, contact the manufacturer or an authorized distributor.
Err5	Boot check failed	Contact the manufacturer or an authorized distributor.

* Only available in model S304.

Err1: Sensor probe grounded

Error code “Err1” indicates that the sensor probe is grounded.

- Check the ground connections, and make sure that the device has been connected to ground properly.
- Make sure that there is no contact between the sensor probe and the duct or pipe wall.
- Remove the device from the process, clean it with non-abrasive methods, and install it back to the process.

If the probe is constantly grounded or it gets repeatedly grounded during normal operation, contact an authorized distributor to have either an air purge adapter or a coated probe installed.

For more information about ground connections, see section **Grounding** in chapter **Electrical installation**.

For more information about cleaning and inspecting the probe, see chapter **Maintenance and inspection**.

For more information about optional functions and accessories, see section **Features and accessories** in chapter **Product overview**.

Err2: Zero/span check failed

Error code “Err2” indicates that zero/span check has failed. This happens when the device is unable to compensate for the drift, or when the drift is >10% after the first zero/span check. There are two possible causes for this:

- Measurement response is drifting due to faulty components, for example due to heat damage.
- Internal signal generator is damaged.

To determine the cause of zero/span check failure, you can use Reference Signal Generator to check if the measurement response is within the expected range.

- If the results of the check with Reference Signal Generator are within the expected range, the internal signal generator of the device is damaged. In this case the measurement results are most likely accurate, but the device is unable to confirm that there is no drift.
- If the check with Reference Signal Generator fails, the measurement response is drifting due to component failure. In this case the measurement response no longer corresponds to the actual dust concentration, and the measurement results are false.

In both cases, return the device to the manufacturer or an authorized distributor for maintenance and repair.

Err3: Flow compensation input failed



Error code “Err3” is only available in model S304.

Error code “Err3” indicates that the device has failed to read the flow velocity measurement from the external flowmeter when the flowmeter compensation is active.

- Verify that the external flowmeter is transmitting valid output signal.
- Check that the values for parameter 7 and 8 have been set properly and that flow velocity compensation is active.

For more information about flow velocity compensation, see section **Analog mA input** in chapter **Electrical installation** and section **Parameters 7 and 8: Flow velocity compensation** in this chapter.

Err4: Auto Setup failed

Error code “Err4” indicates that Auto Setup function has failed.

- Run Auto Setup again.
- If the problem persists, contact the manufacturer or an authorized distributor.

For more information about Auto Setup feature, see section **Auto setup** in chapter **Commissioning and system setup**.

Err5: Boot check failed

Error code “Err5” indicates that the device has failed to perform internal functions that are essential to its operation. In this case, contact the manufacturer or an authorized distributor.

9.4.2 Display indicates “- -.- -”

Four dashes (- -.- -) on the device display indicate that the parameters for displaying the measurement results are set improperly. The correct procedure to fix this depends which unit of measurement you want to display the measurement results with.

Displaying measurement results in mA or % of total range

If you want to display the measurement results in mA or as % of total range:

1. Press K0 (+) key to enter MAINTENANCE mode.
2. Navigate to parameter 1.
 - Enter parameter value 000 to display the measurement result as % of total range.
or
 - Enter parameter value 001 to display the output signal level in mA.
3. Press K2 (↔) key to save the value, and press K3 (←) key to exit and return to normal operation.

Displaying measurement results in mg/m³

If you want to display the measurement results in mg/m³:

1. Press K0 (+) key to enter MAINTENANCE mode.
2. Enter the values α and β of the calibration equation $y_i = \alpha + \beta x_i$ to parameters 11, 12, 13 and 14. After setting the value for each parameter, save the value by pressing K2 (↔) key.
See section **Parameters 11 to 14: Displaying measurement results in mg/m³** for information about the calibration equation and individual calibration parameters.
3. Navigate to parameter 10.
4. Enter parameter value 002 and press K2 (↔) key to save the value.
5. Navigate to parameter 1.
6. Enter parameter value 002 and press K2 (↔) key to save the value.
7. Press K3 (←) key to exit and return to normal operation.

9.4.3 Display indicates “[n] - - -”

When setting parameter values, the display can indicate “[n] - - -”, where [n] is the parameter number and dashes have replaced the parameters values. This usually means that the device has not been properly commissioned to accept parameter values. For example, if you attempt to set parameter value for the measurement range (parameter 3) without running Auto Setup, the displays indicate “3 - - -”.

Make sure that you have commissioned and set up the device according to instructions in chapter **Commissioning and system setup**.

9.4.4 No output signal

If the device does not generate a valid output signal during normal operation:

- Make sure that the device is connected to a power source and that all electrical connections are made correctly.
- Make sure that the power supply is ON.
- Make sure that normal processes are running.
- Perform Auto Setup.

9.4.5 No response after Auto Setup

If the device does not respond after you have performed Auto Setup:

- Make sure that the device is connected to a power source and that all electrical connections are done correctly.
- Make sure that the power supply is ON.
- Make sure that the signal is not leaking to ground. Possible causes for a signal leak are:
 - Contact between the sensor probe and the duct wall.
 - Condensed droplets in the gas flow.
 - Sticky dust buildup on the sensor base, which can cause bridging between the sensor probe and the duct wall.
- Make sure that normal processes are running during Auto Setup.

9.4.6 Device lid does not open

The device lid can become stuck if too much dust accumulates between the threads. In this case, you can use a rod or other suitable tool to force the lid open. To force the lid open:

1. Place a rod or other suitable tool between two opposite slots on the device lid. The lid has four slots.

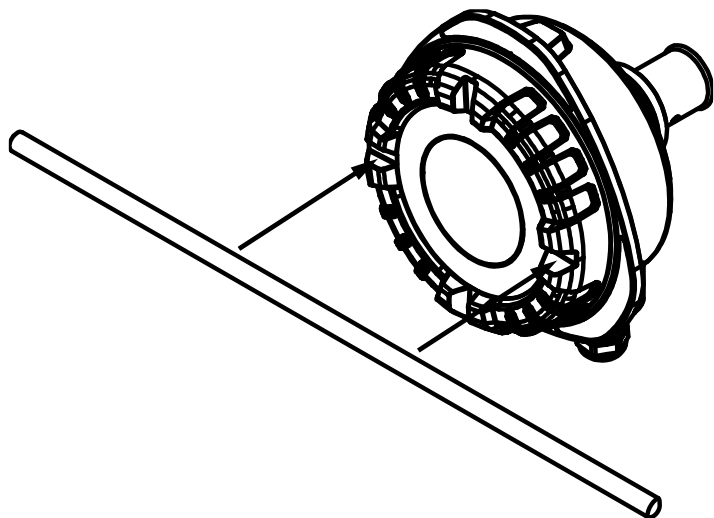

2. Use the rod to turn the lid counterclockwise. The slots lock the rod in place, allowing you to force the lid open.

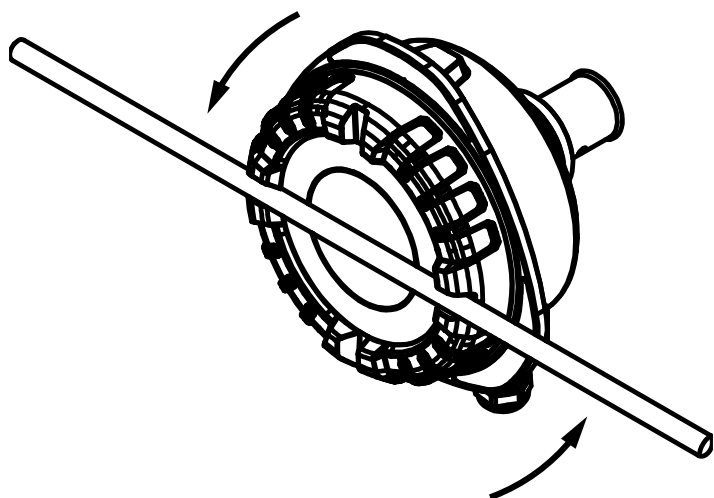

The design of the slots makes the rod slip out if you attempt to use it to turn the lid clockwise. This prevents you from using a tool to close the lid by force.

10 Maintenance and inspection

10.1 Safety precautions



Read chapter “Safety” carefully before performing maintenance on the device.

The device must not be modified or repaired in any way that is not specifically described in this manual. Do not perform any mechanical or electrical repairs without contacting the manufacturer or an authorized distributor.

Only original Sintrol parts can be used for repairs. If third-party spare parts are used, the manufacturer cannot guarantee safe operation of the device. The manufacturer or distributor cannot be held liable for any damage, injury or financial loss resulting from improper use.



Wear protective glasses when working on electrical connections.

DANGER!



Poisonous and hot gas hazard

When installing or removing the device, poisonous and hot gas can be released from the duct.



Wear appropriate respiratory and eye protection gear when installing or removing the device. Follow all applicable local and plant-specific safety codes before proceeding.

WARNING!



Risk of burns due to hot components

When installing or removing equipment, the device or the installation surface can be hot.



Wear appropriate heat-resistant gloves and follow all applicable local and plant-specific safety codes before proceeding.

WARNING!



Electric shock hazard

Faulty electrical installations, too high line voltage or incorrect operation of the device can result in an electric shock. Only trained and qualified personnel can install, commission, operate and perform maintenance on the device.

To ensure that performing maintenance on the device is safe, keep the following points in mind:

- Power down the device when you are making electrical connections, when you intend to perform maintenance on it, or in the event of malfunction.
- Make sure that all equipment is properly grounded.
- Never perform maintenance on the device alone.

10.2 Maintenance and inspection interval

The recommended inspection and maintenance intervals depend on the operating conditions. The amount of dust and other possible substances in the measurement air affect how often the sensor must be inspected and cleaned.

During the first months after installation (up to 6 months), it is recommended to perform maintenance on the device monthly. If there is no noticeable dust build-up on the sensor probe and the probe is easy to clean, the maintenance interval can be increased step-by-step.



It is the responsibility of the plant operator to decide what is the appropriate maintenance interval.

A monthly interval is recommended for the visual inspection of the device and testing of the device functions.

If you notice that the device is not operating normally, contact the manufacturer or an authorized distributor. Make sure that an industry specialist inspects and approves the device for use in the monitoring system that the device is part of, and ensures that its use complies with all local safety standards and regulations.

10.3 Maintenance and inspection

Do the following inspections monthly:

- Visually inspect the outer parts of the device, its accessories, and cables. Make sure that there is no obvious visible damage.
- Make sure that the device lid, quick-clamp, cable glands and cables are tightly secured.
- Make sure that the display and LEDs are operating normally.
- Clean the device enclosure, lid and the window.

- Make sure that the measurement results are within the expected range.
- Make sure that the device is properly grounded by touching the enclosure and the probe. The device is properly grounded if:
 - The output signal does not change when you touch the enclosure.
 - The output signal changes when you touch the probe.
- If applicable, make sure that the air supply for the air purge is operating normally, and that the inlet air connection is tight.
 - Recommended airflow is 50 l/min \pm 10%.
 - The required air pressure depends on the flow resistance and process pressure.

In addition, do the following maintenance tasks at regular intervals determined by the plant operator:

- Clean the sensor probe by wiping it with a cloth. If necessary, you can use a brush.

10.3.1 Removing device from the process

For cleaning and testing that the probe reacts properly to being touched and to clean it, the device must be removed from the process. To remove the device from the process:

1. Loosen the quick-clamp connector that is used to secure the device to the process connection.

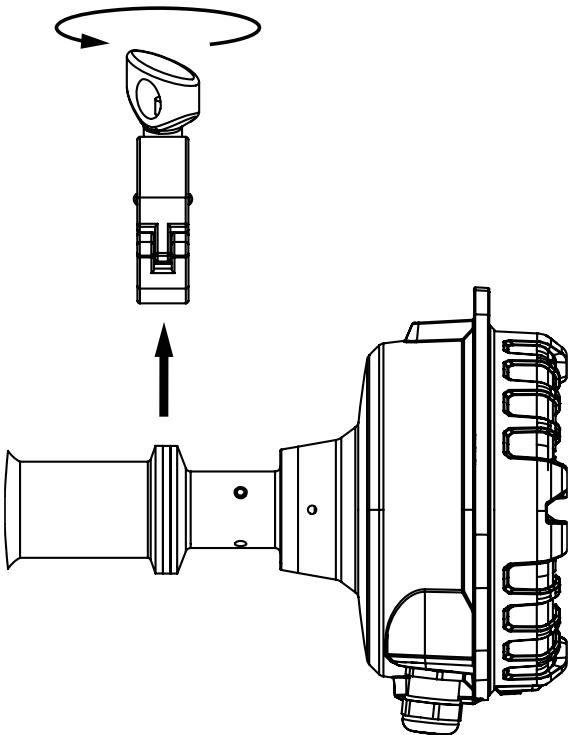

2. Remove the device from the process by lifting it out of the process connection. Leave the quick-clamp gasket in place on the process connection.

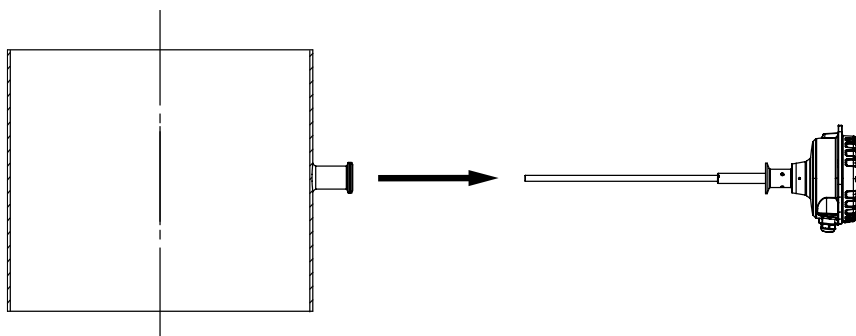

3. Fit the end cap on the process connection.

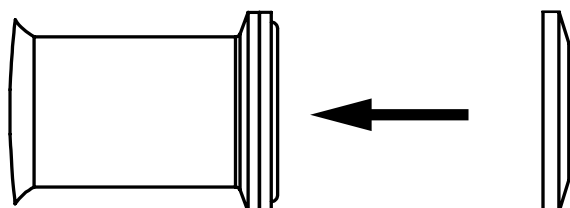

4. Secure the end cap in place with the quick-clamp connector.

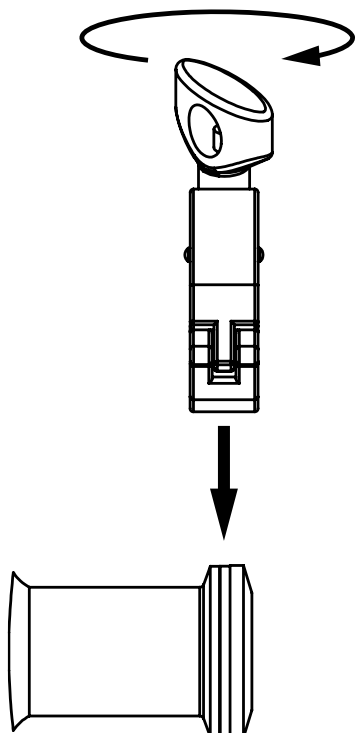

5. Do necessary inspections and maintenance on the probe.
6. When you are done, install the sensor again by removing the end cap and securing the sensor in place with the quick clamp.

10.3.2 Cleaning supplies

Use a cloth or paper towel to clean the device enclosure and probe. If necessary, you can apply mild detergent or isopropyl alcohol to remove stuck-on dirt.

NOTICE

Do not use any abrasive material or corrosive substances to clean the device enclosure or sensor probe. It can cause damage to the device or probe and influence the measurement results.

You can use a steel brush to gently clean a standard uncoated steel probe, for example if the probe is encrusted with burned particles from the process.

10.3.3 Maintenance of Teflon-coated probe

NOTICE

If you have a Teflon-coated probe, only use soft cloth to clean it. If you use other kinds of cleaning supplies, the Teflon coating can break. Always handle a Teflon-coated probe with care.

If the dust build-up on a Teflon-coated probe is impossible to clean, remove the outer translucent Teflon sleeve and replace it with a new one. Contact the manufacturer or an authorized distributor for information on how to order a spare Teflon sleeve for your probe.

The inner black coating of the probe is a second layer of very fine Teflon, which is the actual insulating part of the probe and must not be scratched.



If you damage the second layer of Teflon, the probe must be replaced. Contact the manufacturer or an authorized distributor for information on how to have the probe replaced.

10.4 Returns

If you need to return a defective device for repair, replacement or disposal, contact the manufacturer or an authorized distributor. Return the device in its original packaging, or in a suitable secure container.

Contact details for the manufacturer's offices are available on the back cover of this user manual, and online at <https://sintrol.com/contact/>.

11 Recycling and disposal

11.1 Packaging



Recycle any paper, cardboard or plastic material used in the product packaging, and sort them in an appropriate recycling container.

Any non-recyclable packaging material must be disposed of with general waste.

11.2 Device



Electronic devices that are marked with this symbol must not be disposed of with general or household waste. If a defective or broken-down device cannot be repaired, it must be recycled and disposed of in accordance with WEEE directive (2012/19/EU) or other applicable local regulations.

12 Specifications

For dimensions, see section **Dimension drawings** in chapter **Product overview**.

General information

Product name:	S303, S304
Measured objects:	Total suspended particles (TSP)
Measurement principle:	Inductive electrification
Measurement range:	Detection limit 0.01 mg/m ³ Max. range up to several g/m ³ depending on operating conditions
Ingress protection:	IP66
Power supply requirements:	24 V DC ±10% 100 ... 240 V AC ±10%, 50 / 60 Hz
Power consumption:	Up to 10 W DC / AC
Output signals:	<ul style="list-style-type: none"> • 2 × Independent SPDT dry contact relays, max. 30 V DC / 5 A or 240 V AC / 5 A, $\cos \varphi = 1$ • Isolated active 4 ... 20 mA output loop, max. loop resistance 250 Ω
Communication interface:	<ul style="list-style-type: none"> • 2 × Serial communication RS-485 • USB • Radio frequency (RF)*
Communication protocol:	<ul style="list-style-type: none"> • Modbus RTU (with RS-485) • Sintrol network (with USB, RF and RS-485)

Physical characteristics

Enclosure:	Aluminum
Wetted parts:	<ul style="list-style-type: none"> • Probe: Stainless steel (316L) • Insulation: Polyphenylene sulfide (Ryton R-4)
Weight:	1.5 kg (3.3 lb)

Ambient conditions

Temperature:	-40 ... 60 °C (-40 ... 140 °F)
Humidity:	Max. 95 % relative humidity (non-condensing)

* Requires optional RF antenna

Process conditions

Temperature:	<ul style="list-style-type: none"> • Max. 300 °C (572 °F), optionally up to 700 °C (1292 °F) • Max. 250 °C (482 °F) with Teflon-coated probe
Pressure:	<ul style="list-style-type: none"> • Max. 600 kPa (87.02 psi) in temperatures up to 300 °C (572 °F) • Max. 300 kPa (43.51 psi) in temperatures from 300 °C (572 °F) to 700 °C (1292 °F) when high-temperature process connection is used
Flow velocity:	Min. 3 m/s (9.84 ft/s), max. tested 40 m/s (131.23 ft/s)

Wireless communication*

Frequency bands:	<ul style="list-style-type: none"> • 868 MHz, 15 channels • 915 MHz (license-free ISM band)
Transmit power:	Up to +23 dBm, user-adjustable
Receiver sensitivity:	-110 dBm
Communication protocol:	Proprietary Sintrol Network protocol
Typical communication range (non-line of sight)	<ul style="list-style-type: none"> • 868 MHz version • Up to 1000 m (3280 ft) in urban environments**

* Requires optional RF antenna.

** Surrounding structures and other devices using radio frequencies can have significant effect on RF communication range.



Appendix A: ISO 9001 certificate

Visit <https://sintrol.com/company/> for the latest ISO 9001 certificate.

Appendix B: Modbus RTU registers

Full register definitions available from the manufacturer on request.

Default Modbus communication parameters

Baud rate:	19200
Data bits:	8
Stop bits:	1
Parity:	Even

Supported function codes

Input registers (R – Read only)

- 4 – Read Input Registers

Holding registers (R/W – Read and Write)

- 3 – Read Holding Registers
- 6 – Write Single register

Modbus RTU quick reference guide

Description	Register address	R or R/W	Data type	Notes																		
Unscaled measurement data [IEU] MSB	6	R	First 16 bits of a 32-bit integer																			
Unscaled measurement data [IEU] LSB	7	R	Last 16 bits of a 32-bit integer																			
Calibrated measurement data [mg/m3] MSB	8	R	First 16 bits of a 32-bit integer	Value must be divided by 100 to achieve the correct result. For example, value 125 = 1.25 mg/m ³ .																		
Calibrated measurement data [mg/m3] LSB	9	R	Last 16 bits of a 32-bit integer																			
Auto Setup remaining time	34	R	16-bit unsigned integer	Remaining Auto Setup time in seconds																		
Alarm status	50	R	16-bit Boolean values	Alarm status of the device: 0000000000000000[bit1][bit0]: <table border="1" style="margin-left: 20px;"> <thead> <tr> <th></th> <th>Bit 0</th> <th>Bit 1</th> </tr> </thead> <tbody> <tr> <td><u>No alarm</u></td> <td>1</td> <td>1</td> </tr> <tr> <td><u>ALERT</u></td> <td>0</td> <td>1</td> </tr> <tr> <td><u>ALARM</u></td> <td>0</td> <td>0</td> </tr> <tr> <td><u>Maintenance</u></td> <td>1</td> <td>0</td> </tr> <tr> <td><u>Fault</u></td> <td>0</td> <td>0</td> </tr> </tbody> </table>		Bit 0	Bit 1	<u>No alarm</u>	1	1	<u>ALERT</u>	0	1	<u>ALARM</u>	0	0	<u>Maintenance</u>	1	0	<u>Fault</u>	0	0
	Bit 0	Bit 1																				
<u>No alarm</u>	1	1																				
<u>ALERT</u>	0	1																				
<u>ALARM</u>	0	0																				
<u>Maintenance</u>	1	0																				
<u>Fault</u>	0	0																				
Auto Setup command register	1536	W	16-bit integer	1 Start Auto Setup 2 Cancel Auto Setup																		
Signal averaging time	4096	R/W	16-bit unsigned integer	Measurement moving averaging time in seconds, divided by 10. For example, value 100 = 10.0 seconds.																		
Save measurement parameters	1538	W	16-bit integer	1 Save parameters																		



Contact us

FINLAND WORLDWIDE

Helsinki
Tel. +358 9 561 7360
info@sintrrol.com
www.sintrrol.fi
www.sintrrol.com

INDIA Representative office

New Delhi
Tel. +91 98 1167 6061
india@sintrrol.com

CHINA Representative office

Beijing
Tel. +86 10 8788 8681
china@sintrrol.com
cn.sintrrol.com

JAPAN Representative office

Tokyo
Tel. +81 90 8585 1301
japan@sintrrol.com

<https://sintrrol.com/>
<https://sintrrol.com/contact/>



Subject to change without notice.
All rights reserved. © 2021 Sintrol

Revision 6
2021-05-03